

SERVICE MANUAL

AA-2C CHASSIS

<u>MODEL</u>	<u>COMMANDER</u>	<u>DEST.</u>	<u>CHASSIS NO.</u>
<i>KV-32XBR48</i>	<i>RM-Y144</i>	<i>US</i>	<i>SCC-N29B-A</i>
<i>KV-32XBR48</i>	<i>RM-Y144</i>	<i>Canadian</i>	<i>SCC-N30B-A</i>
<i>KV-34XBR48C</i>	<i>RM-Y144</i>	<i>E</i>	<i>SCC-N31B-A</i>
<i>KV-35XBR48</i>	<i>RM-Y144</i>	<i>US</i>	<i>SCC-N29A-A</i>
<i>KV-35XBR48</i>	<i>RM-Y144</i>	<i>Canadian</i>	<i>SCC-N30A-A</i>

<u>MODEL</u>	<u>COMMANDER</u>	<u>DEST.</u>	<u>CHASSIS NO.</u>
<i>KV-35XBR88</i>	<i>RM-Y144</i>	<i>US</i>	<i>SCC-N29C-A</i>
<i>KV-37XBR48M</i>	<i>RM-Y144</i>	<i>E</i>	<i>SCC-N31A-A</i>



RM-Y144

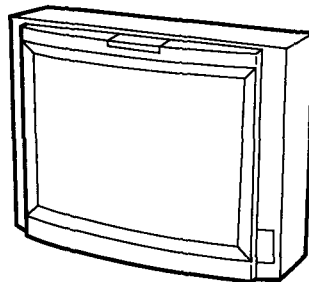

KV-32XBR48/34XBR48C
KV-35XBR48/37XBR48M

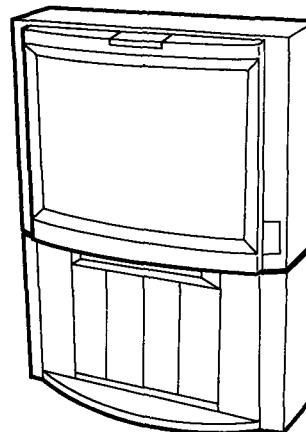

KV-35XBR88



996583601

TRINITRON® COLOR TV
SONY®

※ Please file according to model size. ■

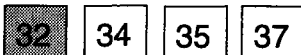

SPECIFICATIONS

	KV-32XBR48	KV-34XBR48C	KV-35XBR48	KV-35XBR88	KV-37XBR48M
Power requirements	120 V, 60 Hz	220 V, 50/60 Hz	120 V, 60 Hz	120 V, 60 Hz	120 V, 60 Hz
Number of inputs / outputs					
Video ¹⁾	3	3	3	3	3
S video ²⁾	2	2	2	2	2
Audio ³⁾	4	4	4	4	4
Audio out ⁴⁾	1	1	1	1	1
Monitor out ¹⁾	1	1	1	1	1
TV out ¹⁾	1	1	1	1	1
S-Link	YES	YES	YES	YES	YES
Y, B-Y, R-Y ⁵⁾	1	1	1	1	1
Speaker output (W)	15W x 2	15W x 2	15W x 2	15W x 2	15W x 2
Power consumption (W)					
in use (Max.)	195W	195W	198W	198W	198W
in standby	15W	17W	15W	15W	5W
Dimensions (W/H/D)					
(mm)	861 x 652.5 x	861 x 652.5 x	936 x 706.5 x	936 x 1201.5 x	936 x 706.5 x
(in.)	603 mm 33 x 25 ³ / ₄ x 23 ³ / ₄ in.	603 mm 33 x 25 ³ / ₄ x 23 ³ / ₄ in.	636.5 mm 36 ⁷ / ₈ x 27 ⁷ / ₈ x 24 ³ / ₄ in.	697 mm 36 ⁷ / ₈ 47 ³ / ₄ x 27 ¹ / ₂ in.	626.5 mm 36 ⁷ / ₈ x 27 ⁷ / ₈ x 24 ³ / ₄ in.
Mass (kg)	72 kg	72 kg	90 kg	125 kg	90 kg
(lbs)	158 lbs 12 oz	158 lbs 12 oz	198 lbs 7 oz	276 lbs 0 oz	198 lbs 7 oz

¹⁾ 1 Vp-p, 75 ohms unbalanced, sync negative

²⁾ Y : 1 Vp-p, 75 ohms unbalanced, sync negative

C : 0.286 Vp-p (Burst signal), 75 ohms

³⁾ 500 mVrms (100% modulation), Impedance : 47 kilohms

⁴⁾ More than 408 mVrms at the maximum volume setting
(variable)

More than 408 mVrms (fix)

Impedance : 5 kilohms

⁵⁾ Y : 1.0 Vp-p, 75 ohms, sync negative

B-Y : 0.7 Vp-p, 75 ohms

R-Y : 0.7 Vp-p, 75 ohms

Television system

American TV standard

Channel coverage

VHF : 2-13 / UHF : 14-69 / CATV : 1-125

Picture tube

Hi Black Trinitron® tube

Antenna

75 ohm external terminal for VHF / UHF

Visible Screen size

32-inch picture measured diagonally

(KV-32XBR48, 34XBR48C)

35-inch picture measured diagonally

(KV-35XBR48, 35XBR88, 37XBR48M)

Actual Screen size

34-inch picture measured diagonally

(KV-32XBR48, 34XBR48C)

37-inch picture measured diagonally

(KV-35XBR48, 35XBR88, 37XBR48M)

Supplied accessories

Remote control RM-Y144 (1)

Batteries (2) size AA (R6)

Optional accessories

Connecting cables

RK-74A, RKG-69HG, VMC-10HG,

VMC-720M, VMC-810S / 820S. YC-15V / 30V

TV Stand SU-32XBR48

KV-32XBR48, 34XBR48C

TV Stand SU-35XBR48

KV-35XBR48, 37XBR48C

U / V mixer EAC-66

Design and specifications are subject to change without notice.

SRS (●)® (SOUND RETRIEVAL SYSTEM)

The SRS (●)® (SOUND RETRIEVAL SYSTEM) is manufactured by Sony Corporation under license from SRS Labs, Inc. It is covered by U.S. Patent No. 4,748,669. Other U.S. and foreign patents pending.

The word 'SRS' and the SRS symbol (●) are registered trademarks of SRS Labs, Inc.

SAFETY CHECK-OUT (US model only)

After correcting the original service problem, perform the following safety checks before releasing the set to the customer:

1. Check the area of your repair for unsoldered or poorly-soldered connections. Check the entire board surface for solder splashes and bridges.
2. Check the interboard wiring to ensure that no wires are "pinched" or contact high-wattage resistors.
3. Check that all control knobs, shields, covers, ground straps, and mounting hardware have been replaced. Be absolutely certain that you have replaced all the insulators.
4. Look for unauthorized replacement parts, particularly transistors, that were installed during a previous repair. Point them out to the customer and recommend their replacement.
5. Look for parts which, through functioning, show obvious signs of deterioration. Point them out to the customer and recommend their replacement.
6. Check the line cords for cracks and abrasion. Recommend the replacement of any such line cord to the customer.
7. Check the condition of the monopole antenna (if any). Make sure the end is not broken off, and has the plastic cap on it. Point out the danger of impalement on a broken antenna to the customer, and recommend the antenna's replacement.
8. Check the B+ and HV to see they are at the values specified. Make sure your instruments are accurate; be suspicious of your HV meter if sets always have low HV.
9. Check the antenna terminals, metal trim, "metallized" knobs, screws, and all other exposed metal parts for AC leakage. Check leakage as described below.

LEAKAGE TEST

The AC leakage from any exposed metal part to earth ground and from all exposed metal parts to any exposed metal part having a return to chassis, must not exceed 0.5mA (500 microamperes). Leakage current can be measured by any one of three methods.

1. A commercial leakage tester, such as the Simpson 229 or RCA WT-540A. Follow the manufacturers' instructions to use these instruments.
2. A battery-operated AC milliammeter. The Data Precision 245 digital multimeter is suitable for this job.
3. Measuring the voltage drop across a resistor by means of a VOM or battery-operated AC voltmeter. The "limit" indication is 0.75V, so analog meters must have an accurate low-voltage scale. The Simpson 250 and Sanwa SH-63Trd are examples of a passive VOM that is suitable. Nearly all battery operated digital multimeters that have a 2V AC range are suitable. (See Fig. A)

HOW TO FIND A GOOD EARTH GROUND

A cold-water pipe is guaranteed earth ground; the cover-plate retaining screw on most AC outlet boxes is also at earth ground. If the retaining screw is to be used as your earth-ground, verify that it is at ground by measuring the resistance between it and a cold-water pipe with an ohmmeter. The reading should be zero ohms. If a cold-water pipe is not accessible, connect a 60-100 watt trouble light (not a neon lamp) between the hot side of the receptacle and the retaining screw. Try both slots, if necessary, to locate the hot side of the line, the lamp should light at normal brilliance if the screw is at ground potential. (See Fig. B)

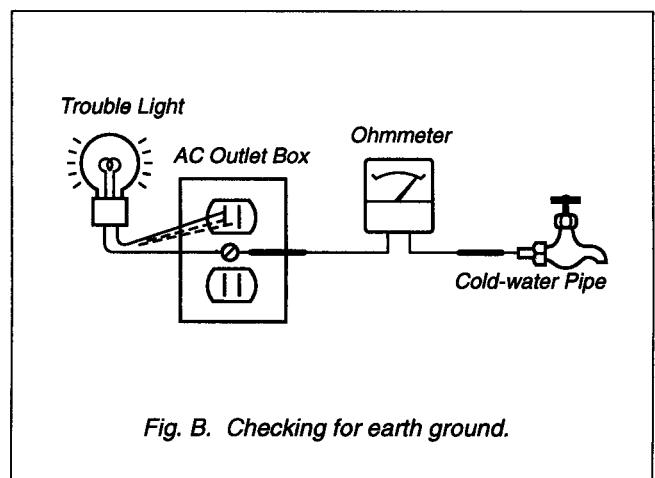
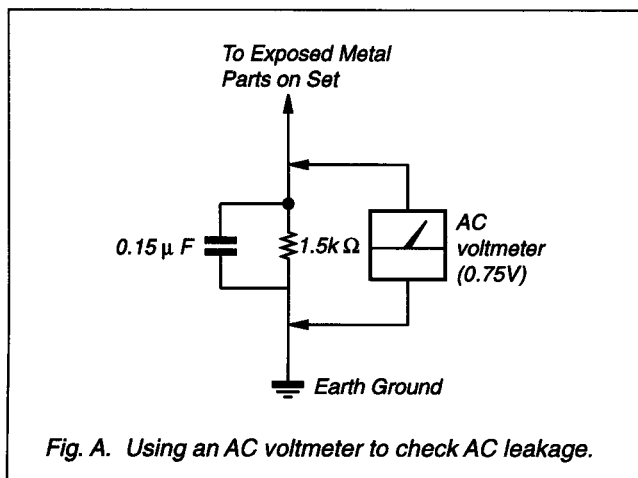

TABLE OF CONTENTS

1. GENERAL	SUB CON Adjustment (SCON) 40
Remote control 5	SUB HUE, SUB COLOR Adjustment (SHUE, SCOL) 40
Connecting and Installing the TV (continued) 5	H. SIZE Adjustment (HSIZ) 40
Basic Set up 10	V. SIZE Adjustment (VSIZ) 41
Using your New TV 11	V. POSITION Adjustment (HPOS) 41
Adjusting your SET UP (menus) 14	H. POSITION Adjustment (HPOS) 41
Operating Video Equipment 19	V LINEARITY (VLIN), V CORRECTION (VSCO), PIN AMP (PAMP), AND PIN PHASE (P PHA) Adjustments 42
Operating a Cable Box or DBS Receiver 20	
Troubleshooting 21	
2. DISASSEMBLY	4. SAFETY RELATED ADJUSTMENTS 43
2-1. Rear Cover and Speaker Removal 22	
2-2-1. Cabinet Base Removal (KV-35XBR88) 22	
2-2-2. FA and FB Boards Removal (KV-35XBR88) 22	
2-3. Chassis Assy Removal 22	
2-4. Service Position 23	
2-5. Control Assy Removal 23	
2-6. Extension Cable 23	
2-7. Picture Tube Removal	
(1) KV-32XBR48/34XBR48C 25	
(2) KV-35XBR48/35XBR88/37XBR48M 25	
2-8. Wire Dressing 26	
3. SET-UP ADJUSTMENTS	5. DIAGRAMS
Beamlanding 27	5-1. Block Diagrams 45
Convergence	5-2. Circuit Boards Location 55
(1) Horizontal and Vertical Static Convergence Adjustment 29	5-3. Printed Wiring Boards and Schamatic Diagrams 55
(2) Dynamic Convergence Adjustment 31	• K Board 57
(3) Screen-corner Convergence Adjustment 32	• A Board 58
Focus 32	• BX Board 66
Screen (G2) 32	• HX Board 69
White Balance Adjustment 33	• HF Board 70
Sub Bright Adjustment 33	• PX Board 70
Electrical Adjustment by Remote Commander 34	• UX Board 76
1. Method of Setting the Service Adjustment mode 34	• C Board 83
2. Memory write confirmation Metho 34	• G Board 86
3. Adjust Buttons and Indicator 34	• WA Board 88
Service Data 35	• FA Board 90
	• FB Board 90
	• AX Board 91
	5-4. Semiconductions 94
	6. EXPLODED VIEWS
	6-1. Chassis 95
	6-2. Picture Tube 96
	6-3. Cabinet Base (KV-35XBR88) 97
	7. ELECTRICAL PARTS LIST 98

(CAUTION)

SHORT CIRCUIT THE ANODE OF THE PICTURE TUBE AND THE ANODE CAP TO THE METAL CHASSIS, CRT SHIELD, OR CARBON PAINTED ON THE CRT, AFTER REMOVING THE ANODE.

WARNING!!

AN ISOLATION TRANSFORMER SHOULD BE USED DURING ANY SERVICE TO AVOID POSSIBLE SHOCK HAZARD, BECAUSE OF LIVE CHASSIS.

THE CHASSIS OF THIS RECEIVER IS DIRECTLY CONNECTED TO THE AC POWER LINE.

SAFETY-RELATED COMPONENT WARNING!!

COMPONENTS IDENTIFIED BY SHADING AND MARK Δ ON THE SCHEMATIC DIAGRAMS, EXPLODED VIEWS AND IN THE PARTS LIST ARE CRITICAL FOR SAFE OPERATION. REPLACE THESE COMPONENTS WITH SONY PARTS WHOSE PART NUMBERS APPEAR AS SHOWN IN THIS MANUAL OR IN SUPPLEMENTS PUBLISHED BY SONY. CIRCUIT ADJUSTMENTS THAT ARE CRITICAL FOR SAFE OPERATION ARE IDENTIFIED IN THIS MANUAL. FOLLOW THESE PROCEDURES WHENEVER CRITICAL COMPONENTS ARE REPLACED OR IMPROPER OPERATION IS SUSPECTED.

(ATTENTION)

APRES AVOIR DECONNECTE LE CAP DE L'ANODE, COURT-CIRCUITER L'ANODE DU TUBE CATHODIQUE ET CELUI DE L'ANODE DU CAP AU CHASSIS METALLIQUE DE L'APPAREIL, OU AU COUCHE DE CARBONE PEINTE SUR LE TUBE CATHODIQUE OU AU BLINDAGE DU TUBE CATHODIQUE.

ATTENTION!!

AFIN D'EVITER TOUT RISQUE D'ELECTROCUTION PROVENANT D'UN CHÂSSIS SOUS TENSION, UN TRANSFORMATEUR D'ISOLEMENT DOIT ETRE UTILISÉ LORS DE TOUT DÉPANNAGE. LE CHÂSSIS DE CE RÉCEPTEUR EST DIRECTEMENT RACCORDÉ À L'ALIMENTATION SECTEUR.

ATTENTION AUX COMPOSANTS RELATIFS À LA SÉCURITÉ!!

LES COMPOSANTS IDENTIFIÉS PAR UNE TRAME ET PAR UNE MARQUE SUR LES SCHÉMAS DE PRINCIPE, LES VUES EXPLOSÉES ET LES LISTES DE PIÉCES SONT D'UNE IMPORTANCE CRITIQUE POUR LA SÉCURITÉ DU FONCTIONNEMENT. NE LES REMPLACER QUE PAR DES COMPOSANTS SONY DONT LE NUMÉRO DE PIÉCE EST INDIQUÉ DANS LE PRÉSENT MANUEL OU DANS DES SUPPLÉMENTS PUBLIÉS PAR SONY. LES RÉGLAGES DE CIRCUIT DONT L'IMPORTANCE EST CRITIQUE POUR LA SÉCURITÉ DU FONCTIONNEMENT SONT IDENTIFIÉS DANS LE PRÉSENT MANUEL. SUIVRE CES PROCÉDURES LORS DE CHAQUE REMPLACEMENT DE COMPOSANTS CRITIQUES, OU LORSQU'UN MAUVAIS FONCTIONNEMENT EST SUSPECTÉ.

SECTION 1 GENERAL

The operation instruction mentioned here are partial abstracts from the Operating Instruction Manual. The page numbers of the Operating Instruction Manual remain as in the manual. (Part no · 3-860-371-21)

Remote Control

In the instructions that follow, we will refer to the buttons on your remote control. Keep this flap unfolded and use this page for reference.

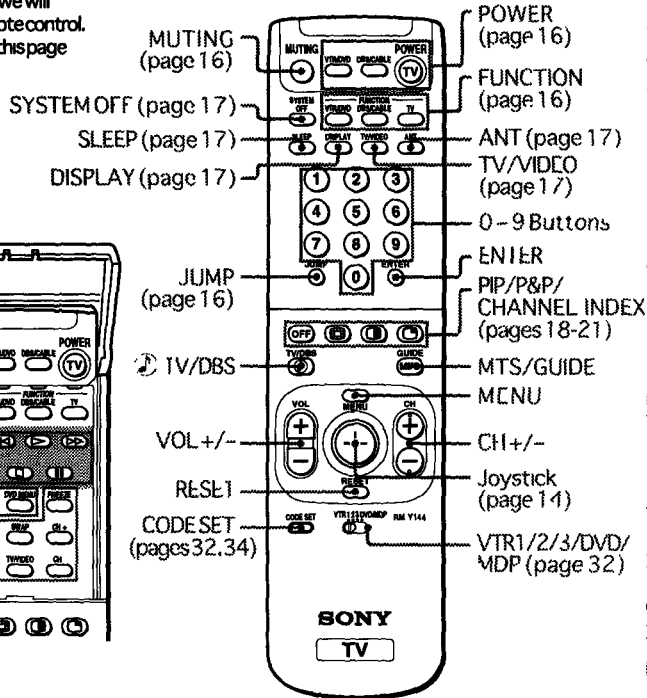
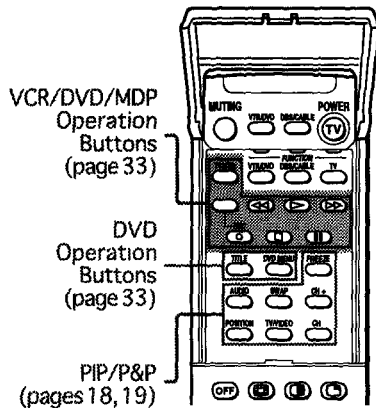

Getting to know the buttons on the remote control

Names of the buttons on the remote control are presented in different colors to represent the available functions.

Button color:

Black Press to select the component you want to control; e.g. VTR (VCR)/MDP/DVD Player, DBS (Direct Broadcast Satellite)/CABLE, or TV.

Green Buttons relevant to power operations, like turning the TV, DBS (Direct Broadcast Satellite)/CABLE, or VTR (VCR)/MDP/DVD Player on or off.

Label color:

White TV/VTR (VCR)/MDP/DVD Player/DBS (Direct Broadcast Satellite)/CABLE operation buttons

Yellow PIP, P&P, and CHANNEL INDEX operation buttons

Blue DBS (Direct Broadcast Satellite) operation buttons.

Green S-Link operation buttons

Pink DVD Player operation buttons.

For a detailed explanation of most buttons, see "Watching the TV" on page 16.

Connecting and Installing the TV (continued)

Connecting an antenna/cable TV system with a VCR

- 1 Attach the coaxial connector from your cable or antenna to IN on your VCR
- 2 Using AUDIO/VIDEO connectors, connect AUDIO and VIDEO OUT on your VCR to AUDIO and VIDEO IN on your TV (Yellow-VIDEO, White-AUDIO Left, Red-AUDIO Right).
- 3 Using a coaxial connector, connect OUT on your VCR to VHF/UHF on your TV

Disconnect all power sources before making any connections.

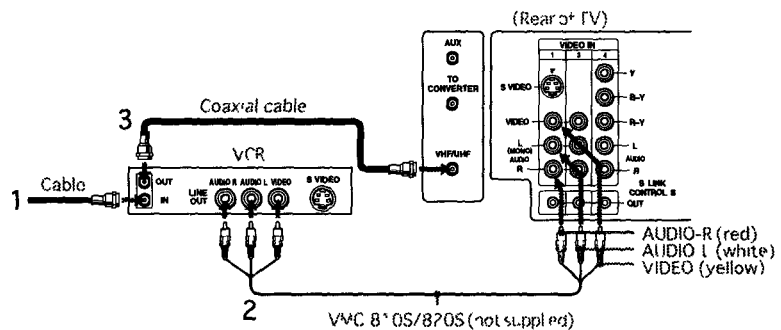

Connecting to an S Video equipped VCR

- 1 Attach the coaxial connector from your cable or antenna to IN on your VCR.
- 2 Using AUDIO connectors, connect AUDIO OUT on your VCR to AUDIO IN on your TV (White-AUDIO Left, Red-AUDIO Right).
- 3 Using a coaxial connector, connect OUT on your VCR to VHF/UHF on your TV.
- 4 Using an S VIDEO connector, connect S VIDEO on your VCR to S VIDEO on your TV

Note:

- If you are connecting a monaural VCR, connect only the single audio output to the left (MONO) input on your TV.

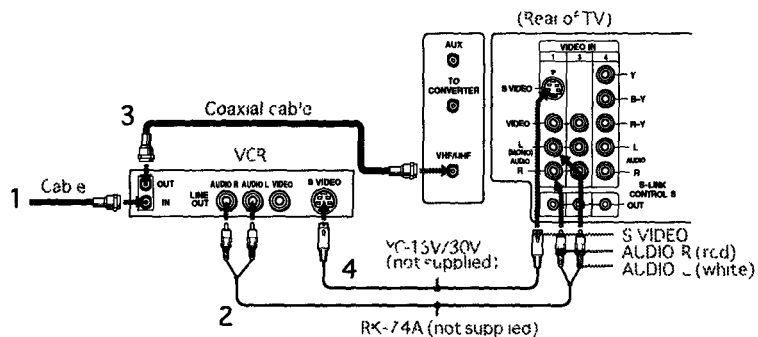

Connecting a VCR and TV with a cable box

- 1 Connect the single (input) jack of the Splitter to your incoming cable connection, and connect the other two (output) jacks (using coaxial cable) to IN on your cable box and VHF/UHF on your TV.
- 2 Using a coaxial connector, connect OUT on your cable box to IN on your VCR
- 3 Using AUDIO/VIDEO connectors, connect AUDIO and VIDEO OUT on your VCR to AUDIO and VIDEO IN on your TV (Yellow-VIDEO, White-AUDIO Left, Red-AUDIO Right).

Connecting to an S Video equipped VCR with a cable box

- 1-2 Perform as described above.
- 3 Using AUDIO connectors, connect AUDIO OUT on your VCR to AUDIO IN on your TV (White-AUDIO Left, Red-AUDIO Right)
- 4 Using an S VIDEO connector, connect S VIDEO on your VCR to S VIDEO on your TV

Note:

- To view scrambled channels through your cable box, select the video input which your cable box is connected to by pressing TV/VIDEO

Disconnect all power sources before making any connections.

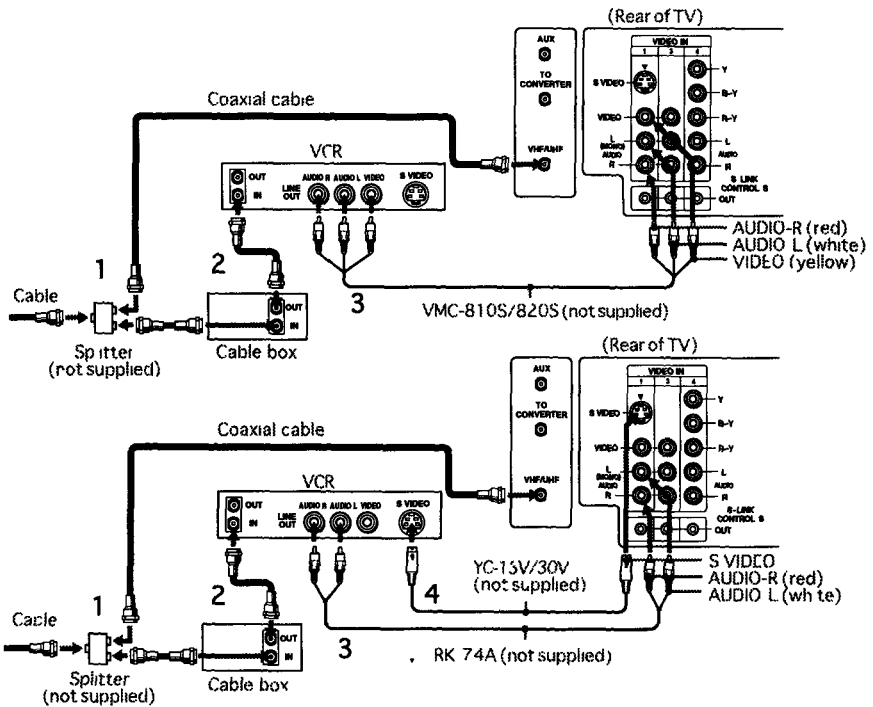

5

Connecting and Installing the TV (continued)

Connecting a DBS (Direct Broadcast Satellite) receiver

- 1 Connect the cable from your satellite antenna to your DBS receiver.
- 2 Attach the coaxial connector from your cable or antenna to VHF/UHF on your TV.
- 3 Using AUDIO/VIDEO connectors, connect AUDIO and VIDEO OUT on your DBS receiver to AUDIO and VIDEO IN on your TV.

Connecting a DBS (Direct Broadcast Satellite) receiver and a VCR

- 1 Connect the cable from your satellite antenna to your DBS receiver.
- 2 Attach the coaxial connector from your cable or antenna to VHF/UHF IN on your VCR.
- 3 Using a coaxial connector, connect VHF/UHF OUT on your VCR to VHF/UHF on your TV.
- 4 Using AUDIO/VIDEO connectors, connect AUDIO and VIDEO OUT on your DBS receiver to AUDIO and VIDEO IN on your VCR.
- 5 Using AUDIO/VIDEO connectors, connect AUDIO and VIDEO OUT on your VCR to AUDIO and VIDEO IN on your TV.

Note:

- To view input from the DBS or VCR, select the video input which your DBS receiver or VCR is connected to by pressing TV/VIDEO on the remote control.

Disconnect all power sources before making any connections.

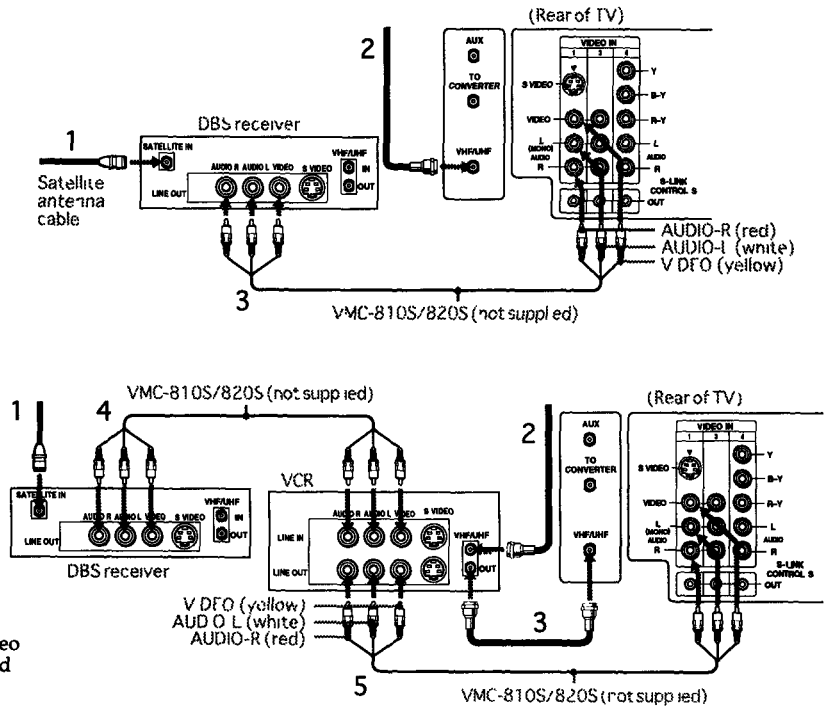

6

Connecting an audio system

For more dynamic sound, connect your audio system to your TV.

- 1 Using AUDIO connectors, connect AUDIO OUT on your TV to one of the unused Line inputs (e.g. Tape-2, AUX1, etc.) on your stereo (White-AUDIO Left, Red-AUDIO Right)
- 2 Set your stereo to the chosen Line input and use the AUDIO menu to set your audio output. (see "SPEAKER" and "AUDIO OUT" on page 24)

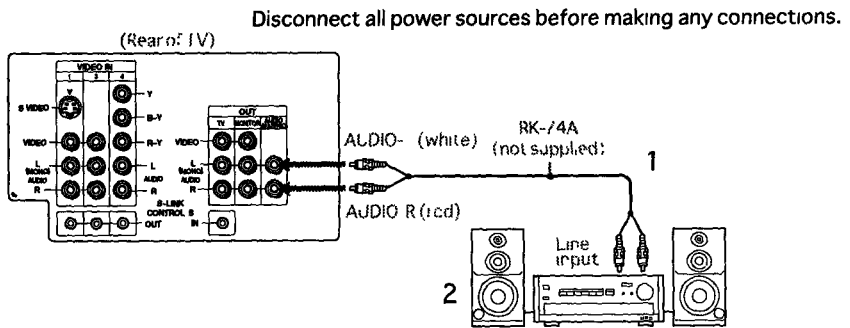

Connecting an AV receiver

For greater control of all audio and video equipment, connect your AV receiver

- 1 Using AUDIO/VIDEO connectors, connect VIDEO 1 IN on your TV to Monitor AUDIO and VIDEO OUT on your AV receiver.
- 2 Using AUDIO/VIDEO connectors, connect TV OUT on your TV to TV AUDIO and VIDEO IN on your AV receiver

Note:

- You may want to use CHANNEL FIX to fix your TV's input to the AV receiver (VIDEO 1). (see "CHANNEL SET UP" on page 26)

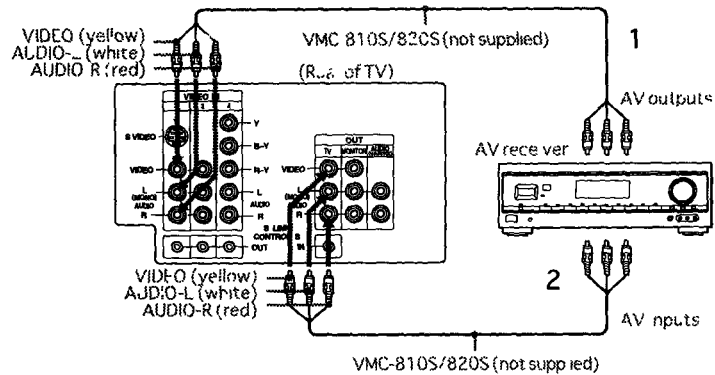

7

Connecting and Installing the TV (continued)

Connecting two VCRs for tape editing using MONITOR OUT

MONITOR OUT gives you the ability to use a second VCR to record a program being played by the primary VCR or to perform tape editing and dubbing

- 1 Connect the VCR intended for playback using the connection instructions on page 4 of this manual
- 2 Using AUDIO/VIDEO connectors, connect AUDIO and VIDEO IN on your VCR intended for recording to MONITOR AUDIO and VIDEO OUT on your TV.

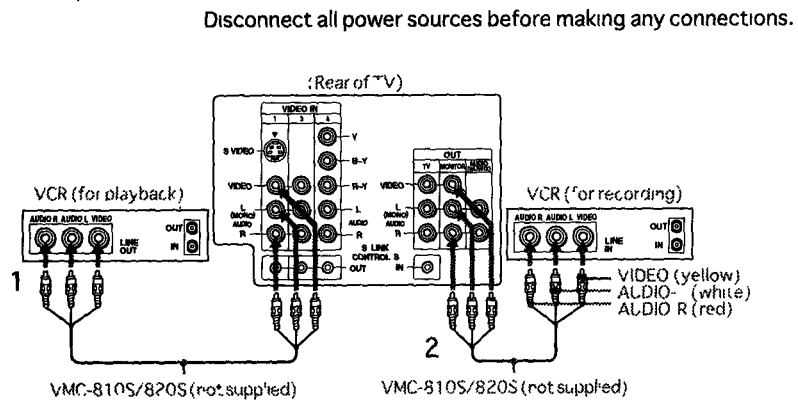

Notes:

- Do not change the input signal while editing through MONITOR OUT
- When connecting a single VCR to the TV; if VCR LINE OUT is connected to TV VIDEO IN, do not connect the TV MONITOR OUT jacks to the VCR LINE INPUT (see right). Doing so will cause program interference and other viewing problems

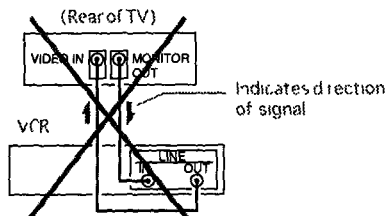

8

Connecting a DVD Player (Upper illustration)

Using AUDIO/VIDEO connectors, connect VIDEO 1 IN on your TV to LINE OUT on your DVD Player.

Connecting a DVD Player with component video output connectors (Lower illustration)

- Using AUDIO connectors, connect AUDIO R and L of the LINE OUT on your DVD Player to AUDIO R and L on the VIDEO IN 4 panel at the rear of your TV.
- Using three VIDEO connectors, connect Y, B-Y, and R-Y on the COMPONENT VIDEO OUT on your DVD Player to Y, B-Y, and R-Y on the VIDEO IN 4 panel at the rear of your TV.

Notes:

- Some DVD Player terminals may be labeled Y, Cb, and Cr. If so, connect Y (green) to Y, B-Y (blue) to Cb, and R-Y (red) to Cr.
- Because the high quality pictures on a DVD disc contain a lot of information, picture noise may appear. In this case, adjust the SHARPNESS in the VIDEO menu (see SHARPNESS on page 23).

Disconnect all power sources before making any connections.

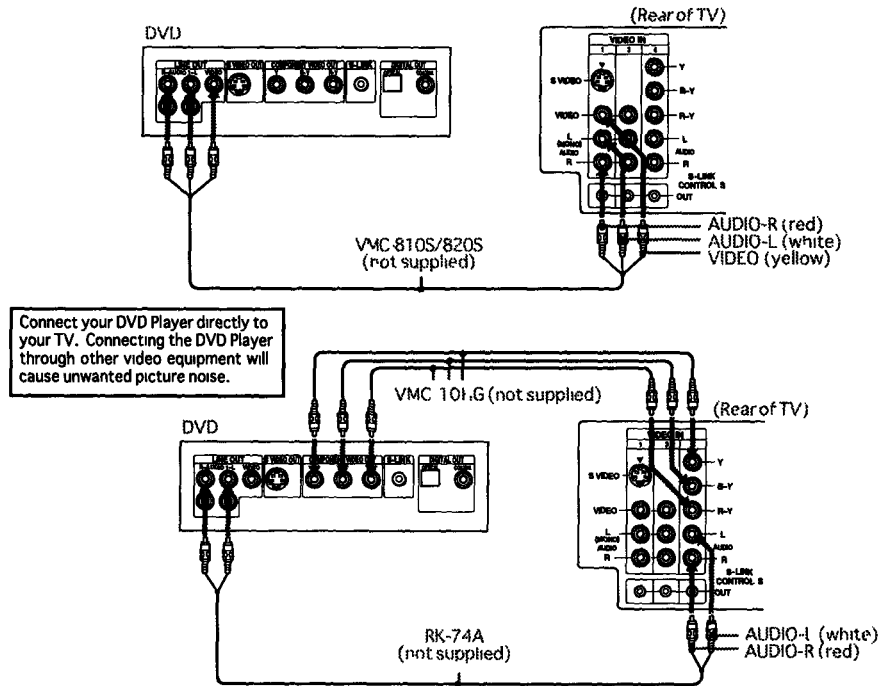

Connecting and Installing the TV (continued)

Connecting a camcorder

Use this connection to view a picture directly from your camcorder.

Using AUDIO/VIDEO connectors, connect AUDIO and VIDEO OUT on your camcorder to AUDIO and VIDEO IN on the front panel of your TV (Yellow-VIDEO, White-AUDIO Left, Red-AUDIO Right).

Notes:

- If you are connecting a monaural camcorder, connect only the single audio output to the left (MONO) input on your TV.
- If you have an S Video equipped camcorder, you can use an S Video connection.

Disconnect all power sources before making any connections.

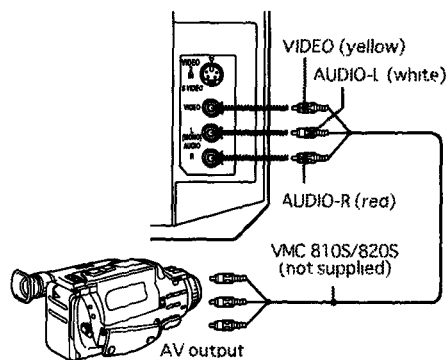

Using the S-Link function

S-Link is a Sony innovation designed to make your Sony components work together. It allows you to automatically switch the TV input mode to video when you press PLAY on your Sony S-Link VCR. It also allows you to turn the VCR and TV off at the same time with the SYSTEM OFF button.

- 1 Connect your VCR. (see "Connecting an antenna/cable TV system with a VCR" or "Connecting to an S Video equipped VCR" on page 4)
- 2 Using an S-LINK connector, connect the S-LINK jacks on your VCR and TV. Ensure that both ends are seated firmly and that the TV S-LINK connector is in the same row as the AUDIO/VIDEO connectors.

Disconnect all power sources before making any connections.

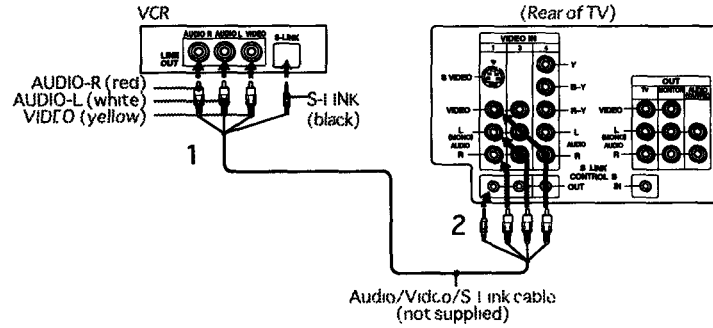

11

Connecting and Installing the TV (continued)

Using the CONTROL S feature

CONTROL S allows you to control your TV and other Sony equipment with one remote control.

To control other Sony equipment with your TV's remote control, connect the CONTROL S IN jack of the equipment to the CONTROL S OUT jack on the TV with the CONTROL S cable.

To control your TV with other Sony equipment's remote control, connect the CONTROL S OUT jack of the equipment to the CONTROL S IN jack on the TV with the CONTROL S cable.

Disconnect all power sources before making any connections.

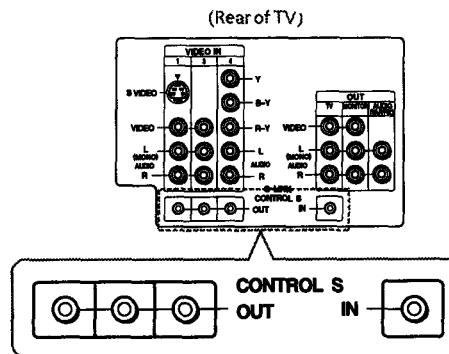

12

Using the Console Box (KV-35XBR88 only)

The console box features electronic sliding doors and three AC outlets.

The AUTO ACCESS switch on the front of the console controls operation of the sliding doors.



AC outlets

Your TV cord has been designed to connect to one of the AC outlets on the rear of the console. You will have two additional outlets to connect accessory equipment to.

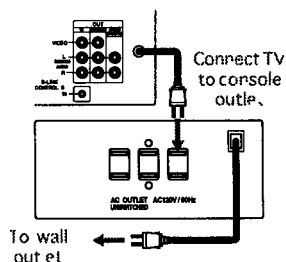

CAUTION

- Do not connect the console AC power cord to a wall outlet until you have completed making all connections
- Do not connect equipment with a combined wattage of more than 300 W/3 A to the console outlet (the wattage of this TV set is 198 W)

Operating your console box automatically (AUTO ACCESS ON)

When the AUTO ACCESS switch is set to ON, the doors will operate automatically. Whenever the sensor detects movement within its range, the doors will open and remain open until the range is clear.

Refer to the following diagram to determine the range of the automatic feature

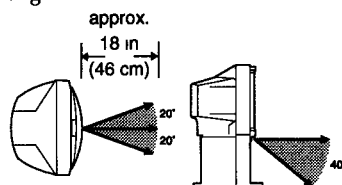

Notes:

- People with small children and pets should consider using the manual feature to avoid possible injury and/or damage.

- The ultrasonic sensor may detect movement, drafts, vibrations, sound waves, or electronic signals that will cause the doors to open inadvertently.
- If the travel of the doors is interrupted, they will reopen automatically and remain opened. When you want to close the doors again, press the OPEN/CLOSE button (or set the AUTO ACCESS switch to OFF)

Operating your console box manually (AUTO ACCESS OFF)

When the AUTO ACCESS switch is set to OFF, the doors will operate manually. Pressing on the OPEN/CLOSE button will cause the doors to open or close and remain in that position until the switch is pressed again.

13

Basic Set up

Inserting Batteries

Insert two size AA (R6) batteries (supplied) by matching the + and - on the batteries to the diagram inside the battery compartment.

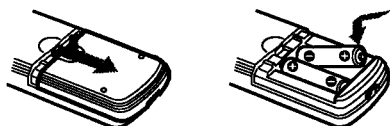

Notes:

- Remove the batteries to avoid damage from possible battery leakage whenever you anticipate that the remote control will not be used for an extended period.
- Handle the remote control with care. Avoid dropping it, getting it wet, or placing it in direct sunlight, near a heater, or where the humidity is high.
- Your remote control can be programmed to operate most video equipment. (see "Operating Video Equipment" on page 32)

Using the Remote Control Joystick

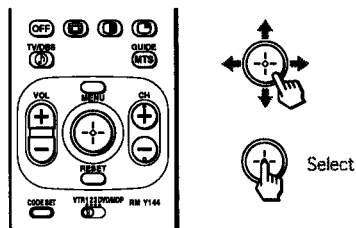

The supplied remote control has a joystick which allows for movement of the on-screen selector in four directions. Pressing up, down, left, or right on the joystick will cause the selector to *move* in the selected direction. Pressing down on the center of the joystick (+) will *activate* the selected item.

Adjusting Sliders

When menu items present a slider (— or —), press up, down, left, or right on the joystick to adjust the setting.

On Line Help/Instructions

Several menu windows will provide prompts and instructions to assist you in navigating through the different functions.

When the instructions are presented, use them to supplement the instructions in this manual.

14

Using your New TV

Setting Up the TV Automatically

The EASY SETUP GUIDE feature will allow you to set the on-screen language and set all receivable channels. The EASY SETUP GUIDE screen will appear every time you turn on the TV until you perform AUTO PROGRAM.

The EASYSETUPGUIDE feature does not apply for installations that use a cable box for all channel selection.

You can also set up the TV manually. (see "Using the SET UP menu" on page 26)

Tips

- Perform this function during the day, with the antenna and/or cable properly connected, to ensure that all available channels will be broadcasting and receivable
- After using EASYSETUPGUIDE you will still have the option of adjusting any of the system settings, like erasing channels, through the SETUP menu (see "CHANNEL SET UP" on page 26)

Using the buttons on the top of the TV:

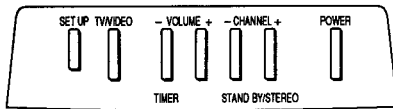

- 1 Press POWER to turn on the TV
The EASY SETUP GUIDE screen appears



- 2 Press CHANNEL + to select ENGLISH, CHANNEL - to select ESPAÑOL or VOLUME + to select FRANÇAIS.

The screen will change to reflect your choice



For a DEMO of functions and menus, press TV/VIDEO

- 3 Press VOLUME - to continue.

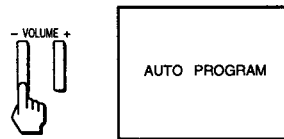

"AUTO PROGRAM" appears and the TV starts scanning and presetting channels automatically. When all the receivable channels are stored, the lowest numbered channel is displayed. If the TV receives cable TV channels, CABLE is set to ON automatically.

To perform AUTO SET UP again

- Press SET UP on top of the TV.
- Press CHANNEL +, CHANNEL - or VOLUME + to select a language
- Press VOLUME - to restore factory settings ("CONTINUE TO AUTO PROGRAM?" will appear on the screen) Press CHANNEL+ to execute or CHANNEL- to exit.
- Press SET UP to exit

Notes:

- Before you perform AUTO SET UP again, make sure that the input from ANT (not AUX) is selected by pressing ANT until "AUX" does not appear next to the channel number
- When you perform AUTO PROGRAM, your CHANNEL FIX, TIMER, and CHANNEL BLOCK settings will be erased

15

Using your New TV (continued)

Watching the TV

Many TV features can be accessed directly through the remote control. The following chart will explain the function of some buttons found on your remote control



REFER TO THE ILLUSTRATION OF THE REMOTE CONTROL ON THE INSIDE FRONT COVER OF THIS MANUAL AS YOU REVIEW THIS CHART

Using the White Labeled Buttons for TV Operations.	
TV (FUNCTION)	Activates the remote control for use with the TV.
TV POWER	Turns the TV on and off. If a video input indication (e.g., VIDEO 1, VIDEO 2) appears on the screen, press TV/VIDEO until a channel number appears.
0 - 9 and ENTER	Use for direct channel selection. Press 0-9 to select a channel (for example, to select channel 10, press 1 and 0), the channel will change after 2 seconds, or you can press ENTER for immediate selection.
CH +/-	Press to scan through the channels (+ up or - down)
VOL +/-	Press to adjust the volume (+ up or - down).
JUMP	Press to alternate or jump back and forth between two channels. The TV will jump between the current channel and the last channel selected using the 0-9 buttons.
MUTING	Press to mute the sound ("MUTING" will appear on the screen). Press again or press VOL + to restore sound.
FREEZE (yellow labeled button)	Press to freeze the picture. Press again or press OFF to cancel.

16

Using the White Labeled Buttons for TV Operations.	
SLEEP	Press repeatedly until the TV displays the approximate time in minutes (30, 60, or 90) that you want the TV to remain on before shutting off automatically. Cancel by pressing until "SLEEP OFF" appears.
DISPLAY	Press repeatedly to step through available displays: Status Channel number, current time, channel caption (if set), and MTS mode (if SAP is selected) are displayed. SAP indication disappears after three seconds. XDS XDS (Extended Data Service) shows a network name, program name, program type, program length, program description, call letters, and time of the show if the broadcaster offers this service. Caption Vision Caption Vision will be displayed on the screen if the broadcaster offers this service. (see right) To cancel the display, press DISPLAY repeatedly until "DISPLAY OFF" appears. "DISPLAY OFF" disappears after three seconds.
TV/VIDEO	Press repeatedly to step through available video inputs. TV, VIDEO 1, VIDEO 2, VIDEO 3 and VIDEO 4 If you select SKIP as a VIDEO LABEL in the SET UP menu, your TV will skip the video input you selected. (see "VIDEO LABEL" on page 27)
ANT (AUX input)	Press to change between the VHF/UHF input and the AUX input. (For detailed connection information, see "Cable box and cable" or "Cable and antenna" on page 3)
MTS	Press to cycle through the Multi-channel TV Sound (MTS) options. (see "MTS" on page 24)
SYSTEM OFF (green labeled button)	Press to turn off the TV and all other equipment connected with S-Link (see "Using the S-Link function" on page 11)

CAPTION VISION
(Closed Caption)

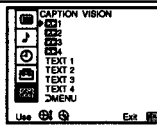

Some programs are broadcast with Caption Vision. To display Caption Vision, select CC1, CC2, CC3, CC4, TEXT1, TEXT2, TEXT3, or TEXT4 from the menu, then press DISPLAY until Caption Vision is displayed.

CC1, CC2, CC3, or CC4 shows you a caption, that is, a printed version of the dialogue or sound effects of a program. (The mode should be set to CC1 for most programs) TEXT1, TEXT2, TEXT3, or TEXT4 shows you text, that is, information presented, using half of the screen. It is not usually related to the program.

Notes:

- Poor reception of TV programs can cause errors in Caption Vision and XDS. Captions may appear with a white box or other errors instead of intended text.
- XDS, Caption Vision, and the status display cannot be used at the same time.

Using your New TV (continued)

Watching Two Programs at One Time — PIP/P&P (Twin View™)



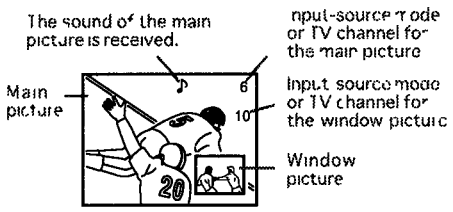

The Picture-in-Picture (PIP) feature allows you to view two channels simultaneously, one in the full size "main" picture and one in a smaller "window" picture.

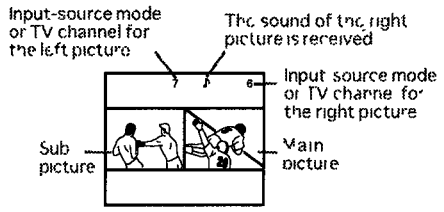







The Picture-and-Picture (P&P) feature allows you to view two channels simultaneously, both in a reduced size screen. The main picture will appear on the right.



➔ REFER TO THE ILLUSTRATION OF THE REMOTE CONTROL ON THE INSIDE FRONT COVER OF THIS MANUAL AS YOU REVIEW THIS CHART

Using the Yellow Labeled Buttons for PIP Operations. Some control buttons for PIP and P&P are located under the cover on the top of the remote control.	
	Press to display a window picture (PIP). Each time you press, the picture size will change (1/4 → 1/9 → 1/16). Press OFF to remove the window picture.
	Press to display right (main) and left pictures (P&P). Press OFF to cancel.
TV/VIDEO 	Press repeatedly to step through available video inputs: TV, VIDEO 1, VIDEO 2, VIDEO 3 and VIDEO 4 . PIP will display the video source in the window picture. P&P will display the video source in the left picture.
AUDIO 	Press to alternate sound between the main picture and the window picture for PIP and the right and left picture for P&P. The symbol "♪" will appear for a few seconds to indicate which picture's sound is being received.

Using the Yellow Labeled Buttons for PIP Operations	
 CH +  CH -	Press to change the TV channel in the secondary picture (+ to increase the channel number and - to decrease). For PIP, the channel in the window picture will change For P&P, the channel in the left picture will change
POSITION 	Press to move the location of the window picture around the main picture <i>This function works only for PIP</i>
FREEZE 	Great for copying down phone numbers, addresses, recipes, etc For PIP: Press to freeze the main picture and remove the window picture. Press PIP or FREEZE to resume PIP viewing Press OFF to cancel and resume normal TV viewing For P&P Press to freeze both pictures Press again to resume P&P viewing or press OFF to cancel and resume normal TV viewing.
SWAP 	Press to switch the audio and video of the main picture and the window picture for PIP, or between the left and right pictures for P&P. Each time you press SWAP, the picture and sound of the two will be exchanged
	Press to access CHANNEL INDEX for direct channel selection (see "Using CHANNEL INDEX" on page 20)
OFF 	Press to cancel PIP or P&P functions and return to normal viewing.

Notes:

- The channel being received through the AUX jack cannot be displayed as a window picture
- If one of the pictures received through PIP/P&P is snowy, the entire screen may appear snowy. In this case, erase the snowy channel (see "CHANNEL ERASE/ADD" on page 26)

Using your New TV (continued)

Using CHANNEL INDEX

You can use the CHANNEL INDEX feature to display multiple channels for direct selection

Channels used for CHANNEL INDEX will come directly from the TV's list of receivable channels (those set during AUTO PROGRAM or through the SET UP menu).

- 1 Press  once to display the current channel in the center of the screen surrounded by the first twelve receivable channels.



A yellow frame will appear to indicate current channel selection

- 2 When you find a channel that you wish to view, use the joystick to move the yellow frame to that picture and press .



The selected channel will be retrieved and displayed for normal viewing



Notes

- You cannot move the yellow frame until all of the surrounding pictures appear.
- The TV will continually update each of the surrounding pictures while the CHANNEL INDEX screen is displayed
- Sound will only be heard from the center picture while the CHANNEL INDEX screen is displayed

- If one of the pictures received through CHANNEL INDEX is snowy, the entire screen may appear snowy. In this case, erase the snowy channel using CHANNEL ERASE/ADD. (see "CHANNEL SET UP" on page 26)

Using the Yellow Labeled Buttons for CHANNEL INDEX Operations. Some control buttons are located under the cover on the top of the remote control.	
	Press to access CHANNEL INDEX. Press again to access the next twelve receivable channels
	Press to cycle through the receivable channels one at a time
	Press to cancel the current operation and return to normal TV viewing
	Press to freeze the center picture. Press again to cancel the frozen picture and resume normal center picture viewing
Using the White Labeled Buttons for Center Picture Operations.	
	Press to cycle the center picture through the video inputs. The surrounding channels will not change.
	Press to replace the center picture with a channel received through the AUX input Press again to return to CATV input
	Press to select the channel for the center picture. (see "Watching the TV" on pages 16-17)

REFER TO THE ILLUSTRATION OF THE REMOTE CONTROL ON THE INSIDE FRONT COVER OF THIS MANUAL AS YOU REVIEW THIS CHART

2 1

Adjusting your SETUP (menus)

Learning Menu Selection

Use the MENU button to access a menu and use the joystick to alter settings. Use the following example to learn how to modify settings.

- 1 Press the MENU button
The main menu appears.

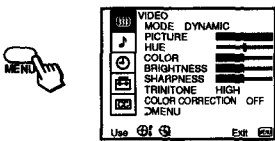

- 2 Press up or down on the joystick to highlight the desired menu and press + to activate it.

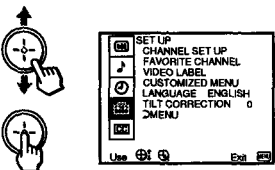

- 3 Press up or down on the joystick until the cursor points to the desired option.

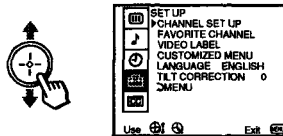

- 4 Press +.
Options for your selection will be displayed

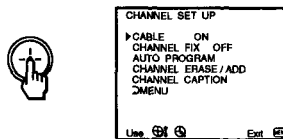

- 5 Press up or down on the joystick to make your selection and and press + to activate it

The previous screen will reappear.

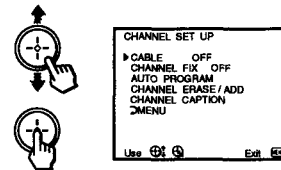

When you are done with changes to the selected menu, choose MENU to return to the main menu. Once you have completed all menu corrections, press MENU on the remote control to exit the menu screens.



Note:

- Pressing MENU on the remote control will allow you to exit from the menus at any time

2 2

III Using the VIDEO Menu

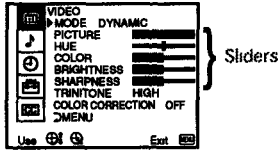

For detailed information on using the remote control to modify menu settings, refer to "Learning Menu Selection" on page 22.

To select the VIDEO III menu:

Display → Highlight III → Select

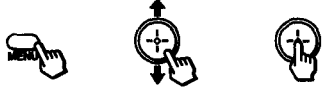

To restore the factory settings

Press RESET on the remote control while the VIDEO menu is selected.

MODE <i>Customized picture viewing</i>	DYNAMIC: Select for enhanced picture contrast and sharpness STANDARD: Select to display a standard picture. MOVIE: Select to display a finely detailed picture SPORTS: Select to display a vivid, bright picture You can alter the VIDEO menu settings (e.g., PICTURE, HUE) for each MODE. Select each mode individually and then press RESET to restore factory settings.
PICTURE <i>Picture Adjustment</i>	Adjust slider right (up) to increase picture contrast and create more vivid color. Adjust slider left (down) to decrease picture contrast and soften the color.
HUE <i>Picture Adjustment</i>	Adjust slider right (up) to increase the green tones. Adjust slider left (down) to decrease the green tones.
COLOR <i>Picture Adjustment</i>	Adjust slider right (up) to increase color intensity. Adjust slider left (down) to decrease color intensity.
BRIGHTNESS <i>Picture Adjustment</i>	Adjust slider right (up) to brighten the picture. Adjust slider left (down) to darken the picture
SHARPNESS <i>Picture Adjustment</i>	Adjust slider right (up) to sharpen the picture Adjust slider left (down) to soften the picture.
TRINITONE <i>White Intensity Adjustment</i>	HIGH: Select to give the white colors a blue tint MEDIUM: Select to give the white colors a white tint NTSC STD: Select to give the white colors a red tint
COLOR CORRECTION <i>Color Ratio Adjustment</i>	Select ON to emphasize reds and blues. Select OFF to emphasize greens

23

Adjusting your SET UP (menus) (continued)

♪ Using the AUDIO Menu

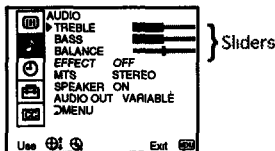

For detailed information on using the remote control to modify menu settings, refer to "Learning Menu Selection" on page 22.

To select the AUDIO ♪ menu:

Display → Highlight ♪ → Select



To restore the factory settings

Press RESET on the remote control while the AUDIO menu is selected.

Tip 📌

Press D for direct selection of an EFFECT setting.

TREBLE <i>Sound Adjustment</i>	Adjust slider right (up) to increase high pitched sounds. Adjust slider left (down) to decrease high pitched sounds.
BASS <i>Sound Adjustment</i>	Adjust slider right (up) to increase low pitched sounds Adjust slider left (down) to decrease low pitched sounds.
BALANCE <i>Sound Adjustment</i>	Adjust slider right (up) to emphasize right speaker volume Adjust slider left (down) to emphasize left speaker volume.
EFFECT <i>Customize sound effect based on the program's audio type</i>	AUTO SRS: Automatically detects signal type and switches the TV effect between SRS and SIMULATED SRS: Produces a dynamic three dimensional sound for stereo signals. SIMULATED: Adds a surround-like effect to mono programs OFF: Normal stereo or mono reception
MTS <i>Enjoy stereo bilingual and mono programs</i>	STEREO: Select for stereo reception when viewing a program broadcast in stereo. SAP: Select to listen to a bilingual broadcast (non-SAP programs will be muted when this feature is selected) MONO: Select for mono reception (use to reduce noise during stereo broadcasts) Quick MTS access: Press MTS on your remote control to cycle through the MTS options as follows: (STEREO → SAP → MONO → STEREO)
SPEAKER <i>Custom selection of audio output source</i>	ON: Select to listen to the sound from the TV speakers alone or the TV speakers and a separate stereo system OFF: Select to turn off the TV speakers and listen to the TV's sound only through external audio system speakers
AUDIO OUT <i>Easy control of volume adjustments</i>	AUDIO OUT can only be set when speakers are set to OFF. VARIABLE: Sound output varies according to the TV settings. VOLUME, BASS, TREBLE, and BALANCE are adjusted through the TV. Useful when you want to use your remote control to control the output of a separate audio system FIXED: Sound output is held at a fixed level VOLUME, BASS, TREBLE, and BALANCE are fixed to the factory settings. VOLUME adjustments are made through your stereo

24

⌚ Using the TIMER Menu

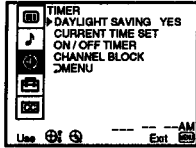

After setting the clock you can use the timer to turn the TV on and off.

For detailed information on using the remote control to modify menu settings, refer to "Learning Menu Selection" on page 22.

To select the TIMER ⌚ menu:

Display → Highlight ⌚ → Select



Tip 💡

Set daylight saving time before setting the clock. Any loss of power will cause these settings to be erased

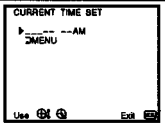
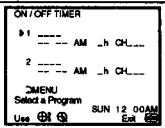
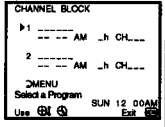
<p>DAYLIGHT SAVING Automatically adjusts the time</p>	<p>Spring: Select YES to compensate for Daylight Saving Time The current time automatically moves ahead one hour Fall: Select NO at the end of Daylight Saving Time The current time moves back one hour.</p>
<p>CURRENT TIME SET Necessary for the TIMER</p>	<p>1 Press \oplus, then press up or down on the joystick until the current day (MON-SUN) is displayed, and press \oplus 2 Press up or down on the joystick until the current hour (01-12) and AM/PM is displayed, and press \oplus 3 Press up or down on the joystick until the current minute (00-59) is displayed, and press \oplus. The Clock has now started. Press MENU to exit</p> 
<p>ON/OFF TIMER Wake up or scheduled viewing</p>	<p>1 Select the desired timer (1 or 2). 2 Press up or down on the joystick until the desired day (MON-SUN) or range of days (EVERY SUN-SAT or EVERY MON-FRI) is displayed, and press \oplus 3 Press up or down on the joystick until the time (hours and minutes) that you want the TV to remain on is displayed, and press \oplus 4 Press up or down on the joystick to set the time duration (maximum of 6 hours) and press \oplus. TO CANCEL THE TIMER FUNCTION, PRESS RESET. 5 Press up or down on the joystick to select the desired channel and press \oplus The timer is now set. The TIMER indicator on your TV will be lit. Press MENU to exit. Performing AUTO PROGRAM will erase all TIMER settings.</p> 
<p>CHANNEL BLOCK Prevent access to certain channels</p>	<p>You will be able to block two channels for a period of up to 12 hours FOLLOW STEPS 1-5 OF "ON/OFF TIMER" ABOVE To erase your CHANNEL BLOCK settings, press RESET while in the CHANNEL BLOCK window. Performing AUTO PROGRAM will erase your CHANNEL BLOCK settings.</p> 

25

Adjusting your SET UP (menus) (continued)

📁 Using the SET UP Menu

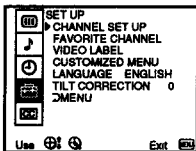

For detailed information on using the remote control to modify menu settings, refer to "Learning Menu Selection" on page 22.

To select the SET UP 📁 menu:

Display → Highlight 📁 → Select

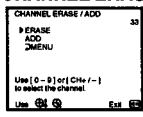
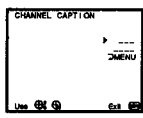

If any menu items are "grayed out", press the ANT button on your remote control so that a channel number appears.

<p>CHANNEL SET UP Basic set up options for viewing</p>	<p>With the CHANNEL SET UP window open: 1 Use the joystick to select the feature you want to change. 2 Press \oplus to access the feature CABLE: Select ON if your TV is connected to a cable system. (AUTO SET UP will set CABLE to OFF automatically if a cable channel is not available) CHANNEL FIX: Press up or down on the joystick to set the TV's input to one of the following options: 2-6: When the cable box is connected to the VHF/UHF input and you do not want to switch to AUX mode. Press DBS/CABLE (FUNCTION) and then CH +/- to change channels. AUX 2-6: When a cable box is connected to AUX and a cable or antenna is connected to VHF/UHF. You can alternate between the two inputs by pressing ANT VIDEO 1: When you have connected video equipment (e.g. AV receiver) and you want the TV input fixed to it. You will be able to alternate between video sources. OFF: When you want to switch CHANNEL FIX off If the TV is in the AUX mode when you turn CHANNEL FIX off, press ANT to return to regular (CATV) mode. TIMER and CHANNEL BLOCK settings are erased when CHANNEL FIX is set AUTO PROGRAM: Signals the TV to automatically program all receivable channels CHANNEL ERASE/ADD: With the CHANNEL ERASE/ADD window open  <ol style="list-style-type: none"> Place the cursor next to ERASE or ADD Select the desired channel using CH +/-, or by selecting with the 0-9 buttons and pressing ENTER Press \oplus CHANNEL CAPTION: With the CHANNEL CAPTION window open:  <ol style="list-style-type: none"> Press \oplus and then press up or down on the joystick to select the desired channel, and press \oplus again Press up or down on the joystick to display the first letter or number of the caption and press \oplus to select it (Repeat until up to four digits are selected) Press \oplus. To erase a Caption, press RESET </p>
---	---

26

FAVORITE CHANNEL <i>User's favorite channels</i>	The FAVORITE CHANNEL feature provides a multi-picture presentation to enable direct channel selection. (for details on how to set up this feature, see "Setting and Selecting FAVORITE CHANNEL" on page 28)
VIDEO LABEL <i>Easy recognition of connected equipment (e.g. DBS, VHS, etc.)</i>	This feature allows you to label each input mode so that you can easily identify the connected equipment (e.g. you can label VIDEO 1 IN as VHS). 1 Press up or down on the joystick to select the input mode you want to label and press \oplus . 2 Press up or down on the joystick to select the label and press \oplus . VIDEO LABEL Options: VIDEO 1: VHS, 8mm, BETA, LD, GAME, DBS, DVD, WEB, RECEIVER, SKIP VIDEO 2/3: VHS, 8mm, BETA, LD, GAME, DBS, DVD, WEB, SKIP VIDEO 4: DVD, SKIP <i>If you select SKIP, your TV will skip this connection when you scan through video sources using the TV/VIDEO button. When VIDEO LABEL is set to WEB, the screen will darken, creating an ideal picture for WebTV viewing.</i>
CUSTOMIZED MENU <i>Frequently used menu items</i>	Use this feature to create a custom menu which contains only those functions that you use most. (for details on how to set up this feature, see "Customizing the Menu" on page 31)
LANGUAGE <i>User's preferred language</i>	Select from available languages to display all menus in your language of choice
TILT CORRECTION <i>Adjust your picture</i>	(KV-35XBR48, 35XBR88, 37XBR48M only) Use this feature to correct any tilt of the picture. Press up or down on the joystick to select a correction between +5 and -5 and press \oplus .



Adjusting your SET UP (menus) (continued)

Setting and Selecting FAVORITE CHANNEL

The FAVORITE CHANNEL feature provides a multi-picture presentation to enable direct channel selection
 Your FAVORITE CHANNEL options can be set automatically or manually.

The factory setting for FAVORITE CHANNEL is AUTO. When FAVORITE CHANNEL is set to AUTO, the last eight channels selected with the 0-9 buttons will be set as FAVORITE CHANNEL options.

Setting FAVORITE CHANNEL manually

1 Select FAVORITE CHANNEL from the SET UP menu.

The FAVORITE CHANNEL menu will appear. If you set CHANNEL CAPTION, captions (e.g. CNN, HBO) for the channels selected will display (see "CHANNEL CAPTION" on page 26)

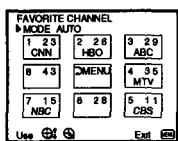

2 Select MODE and press \oplus .

Press up or down on the joystick to display MANUAL and press \oplus .

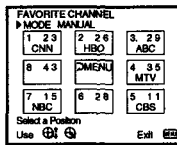

3 Press down on the joystick to select 1 and press \oplus .

Press up or down on the joystick to select a channel and press \oplus .

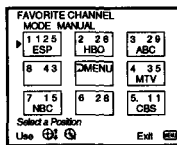

You have now selected a favorite channel for position 1

4 Use the joystick to select other FAVORITE CHANNEL positions and program other favorite channels

5 Press MENU when you are done.

Your favorite channels are now ready to use.

Resetting FAVORITE CHANNEL choices

You have the option of returning to the FAVORITE CHANNEL screen to adjust any of your favorite channel choices.

Simply proceed as described in "Setting FAVORITE CHANNEL manually" (skip step 2 if MANUAL is already selected). When you reach step 3, select the position you want to change and press \oplus . Press RESET to clear the channel for that position

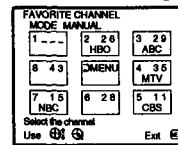

Press up or down on the joystick to select a new channel and press \oplus . Press MENU when you are done.

Note:

- The FAVORITE CHANNEL feature is not available for the AUX input.

Using FAVORITE CHANNEL

You can use the FAVORITE CHANNEL feature to display multiple channels for direct selection.

1 Press ⊕ once.

The current channel will be displayed in the center of the screen surrounded by your eight favorite channels.



A yellow frame will appear to indicate current channel selection. The TV will continually update each of the surrounding pictures.

2 When you find a channel that you wish to view, use the joystick to move the yellow frame to that picture.

The sound of the picture surrounded by the yellow frame will be received.

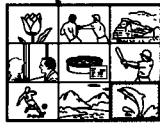

3 Press ⊕ to select the channel.

The selected channel will be retrieved and displayed for normal viewing.



Notes:

- You cannot move the yellow frame until all of the surrounding pictures appear.
- If one of the pictures received through FAVORITE CHANNEL is snowy, the entire screen may appear snowy. In this case, erase the snowy channel using CHANNEL ERASE/ADD. (see "CHANNEL SET UP" on page 26)

29

Adjusting your SET UP (menus) (continued)

Setting and Selecting FAVORITE CHANNEL (continued)



REFER TO THE ILLUSTRATION OF THE REMOTE CONTROL ON THE INSIDE FRONT COVER OF THIS MANUAL AS YOU REVIEW THIS CHART

Using the Yellow Labeled Buttons for FAVORITE CHANNEL Operations. Some control buttons are located under the cover on the top of the remote control.	
FREEZE 	Press to freeze the center picture. Press again to cancel the frozen picture and resume normal FAVORITE CHANNEL viewing.
OFF 	Press to cancel the current operation and return to normal TV viewing.
Using the White Labeled Buttons for Center Picture Operations.	
TV/VIDEO 	Press to cycle the center picture through the video inputs. The surrounding channels will not change.
ANT 	Press to replace the center picture with a channel received through the AUX input. Press again to return to CATV input.
CH or or JUMP and ENTER	Press to select the channel for the center picture. (see "Watching the TV" on pages 16-17)

Customizing the Menu

You have the option of creating a custom menu including up to seven of the menu functions that you use most. You can select any menu items except those found in the SET UP menu. Once you define a custom menu, it will appear first whenever you press the MENU button.

Creating or changing a CUSTOMIZED MENU

- 1 Select CUSTOMIZED MENU from the SET UP menu.

The CUSTOMIZED MENU will appear

- 2 Select CUSTOMIZE and press \oplus .

Press up or down on the joystick to display ON and press \oplus again

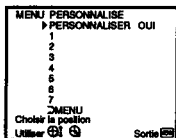

- 3 Press down on the joystick to select 1 and press \oplus .

The menu for selection will appear



- 4 Locate the item you wish to include and press \oplus .

Grayed out items cannot be included in the CUSTOMIZED MENU.

The CUSTOMIZED MENU will return with your choice in position 1.

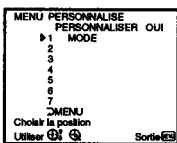

- 5 Repeat steps 3 and 4 to assign items to any or all of the remaining positions (2 - 7)

Items which you have already included will appear in green on the menu for selection.

Press MENU when you are done.

Your CUSTOMIZED MENU will now operate the same as any of the standard menus.

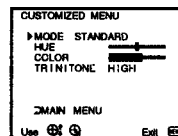

To Access the MAIN MENU from your CUSTOMIZED MENU

Select \triangleright MAIN MENU in the CUSTOMIZED MENU and press \oplus

To reset the CUSTOMIZED MENU choices

When the cursor points to CUSTOMIZE or position 1 to 7 in step 4 of "Creating or changing a CUSTOMIZED MENU", press RESET. All choices will be reset.

To cancel the CUSTOMIZED MENU function

- 1 Select \triangleright MAIN MENU in the CUSTOMIZED MENU window and press \oplus

- 2 Select the CUSTOMIZED MENU from the SET UP menu.

- 3 Select CUSTOMIZE and set it to OFF.

3 1

Operating Video Equipment

Setting the Manufacturer's Code

You can use the supplied remote control to operate Sony or non-Sony video equipment that has an infrared sensor

- 1 Set the VTR 1/2/3/DVD/MDP switch to the position through which you would like to access the video equipment.

The following Sony equipment is preset to each position of the switch:

VTR1 (303)	Beta, ED Beta VCRs
VTR2 (302)	8 mm VCR
VTR3 (301)	VHS VCR
DVD/MDP (751)	DVD Player

- 2 Press CODE SET, VTR/DVD (FUNCTION), the 0-9 buttons to enter the manufacturer's code number (see the following chart), then press ENTER.

For example, to operate a Sony 8mm VCR



If the remote control doesn't work

- Try repeating the set up procedures using the other codes listed for your equipment.

VCR manufacturer code numbers

Manufacturer	Code
Sony	301, 302, 303
Aiwa	338, 344
Admiral (M. Ward)	327
Audio Dynamic	314, 337
Bell & Howell (M. Ward)	330, 343
Broksonic	319, 317
Canon	309, 308
Citizen	332
Craig	315, 302, 332
Criterion	315
Curtis Mathis	304, 338, 309
Daewoo	341, 312, 309
DBX	314, 336, 337
Dimensia	304
Emerson	319, 320, 316, 317, 318, 341
Fisher	330, 334, 335, 333
Funai	338
General Electric	329, 304, 309
Go Video	322
Goldstar	332
Hitachi	306, 304, 305, 338
Instant Replay	309, 308
JC Penney	309, 305, 304, 330, 314, 336, 337
JVC	314, 336, 337
Kenwood	314, 336, 332, 337
LXI (Sears)	332, 305, 333, 334, 330, 335, 338
Magnavox	308, 309, 310
Marantz	314, 336, 337

Marta	332
Memorex	309, 335
Minolta	305, 304
Mitsubishi/MGA	323, 324, 325, 326
Multitech	325, 338, 321
NEC	314, 336, 337
Olympic	309, 308
Optimus	327
Panasonic	308, 309, 306, 307
Pentax	305, 304
Philco	308, 309
Philips	308, 309, 310
Pioneer	308
Quasar	308, 309, 306
RCA/PROSCAN	304, 305, 308, 309, 311, 329, 312, 313, 310
Realistic	309, 330, 328, 335, 324, 338
Sansui	314
Singer	315
Samsung	322, 313, 321
Sanyo	330, 335
Scott	312, 313, 321, 335, 323, 324, 325, 326
Sharp	327, 328
Shintom	315
Signature 2000 (M Ward)	338, 327
Sylvania	308, 309, 338, 310
Symphonic	338
SV2000	338
Tashiro	332
Tatung	314, 336, 337
Teac	314, 336, 338, 337
Technics	309, 308
Toshiba	312, 311
Wards	327, 328, 335, 331, 332
XR-1000	315

3 2

MDP manufacturer code numbers

Manufacturer	Code
Sony	701
Panasonic	704, 710
Pioneer	702

DVD Player manufacturer code numbers

Manufacturer	Code
Sony	751

Tips

- In some rare cases, you may not be able to operate your non-Sony video equipment with the supplied remote control. In this case, please use the equipment's own remote control.
- When you remove the batteries, the code number may revert to the factory setting.

To operate video equipment

- 1 Set the VTR1/2/3/DVD/MDP switch to the position through which you would like to access the video equipment
- 2 Use the VCR/DVD/MDP buttons indicated in the following tables

Operating a VCR using the remote control

To turn On/Off	Press VTR/DVD (POWER) [Green Button]
To select a channel	Press the 0 - 9 buttons
To change channels	Press CH +/-.
To record	Press (REC) while pressing (upper left).
To play	Press (play).
To stop	Press (stop).
To fast forward	Press (FF).
To rewind the tape	Press (REW).
To pause	Press (PAUSE). Press again to resume normal playback.
To search the picture forward or backward	Press (F) or (B) during playback. Release to resume normal playback.
To change input mode	Press TV/VTR

Operating an MDP using the remote control

To turn On/Off	Press VTR/DVD (POWER). [Green Button]
To play	Press (play).
To stop	Press (stop).
To pause	Press (PAUSE). Press again to resume normal playback

To search the picture forward or backward	Press (F) or (B) during playback. Release to resume normal playback.
To search a chapter forward or backward	Press CH +/-.

Operating a DVD Player using the remote control

To turn On/Off	Press VTR/DVD (POWER). [Green Button]
To play	Press (play).
To stop	Press (stop).
To pause	Press (PAUSE). Press again to resume normal playback.
To step through different tracks of an audio disc	Press (F) to step forward or (B) to step backward.
To step through different chapters of a video disc	Press CH+ to step forward or CH- to step backward
To display the Title menu	Press TITLE
To display the DVD menu	Press DVD MENU.
To select tracks directly	Press 0-9 buttons.
To display the menu (Set up)	Press MENU

Operating a Cable Box or DBS Receiver

Setting the Manufacturer's Code

You can program the supplied remote control to operate a cable box or DBS receiver.

Press CODE SET, DBS/CABLE (FUNCTION), the 0-9 buttons to enter the manufacturer's code number (see the following chart), then press ENTER.

For example, to operate a Sony DBS receiver:



Manufacturer code numbers (cable box)

Manufacturer	Code
Hamlin/Regal	222, 223, 224, 225, 226
Jerrold/G. I.	201, 202, 203, 204, 205, 206, 207, 208, 218
Oak	227, 228, 229
Panasonic	219, 220, 221
Pioneer	214, 215
Scientific Atlanta	209, 210, 211
Tocom	216, 217
Zenith	212, 213

Manufacturer code numbers (DBS receiver)

Manufacturer	Code number
Sony	801 (preset code for remote control)
General Electric	802
RCA/PROSCAN	802

To operate the TV

Press TV (FUNCTION). Then use the TV control buttons to control the TV

For more details on operating the cable box or DBS receiver

Refer to the operating instructions that come with the equipment

If the remote control doesn't work

- First, try repeating the set up procedures using the other codes listed for your equipment.

Tips

- If more than one code number is listed, try entering them one by one until you come to the correct code for your equipment
- If you enter a new code number, the code number you previously entered at that setting is erased

- In some rare cases, you may not be able to operate your equipment with the supplied remote control. In this case, use the equipment's own remote control unit
- Whenever you remove the batteries—to replace them, for example—if too much time is taken, the code numbers may revert to the factory setting and must be reset.

■ ■ ■ Troubleshooting

Troubleshooting

No picture (screen not lit), no sound

- Make sure the power cord is plugged in
- Operate with the buttons on the TV and the remote control.
- Check to see if the TV/VIDEO setting is correct: when watching TV, set to TV, and when watching video tapes, set to VIDEO 1, 2, 3 or 4.
- Try another channel. It could be station trouble.
- Perform AUTO SET UP again using the SET UP button to return to the factory preset condition. (see "To perform AUTO SET UP again" on page 15)

Remote control does not operate

- Batteries could be weak. Replace the batteries.
- Press TV (FUNCTION) when operating your TV.
- Make sure the TV's power cord is connected securely to the wall outlet
- Locate the TV at least 3-4 feet away from fluorescent lights.
- Check the S-Link connection. (see "Using the S-Link function" on page 11)
- Check the polarity of the batteries.

Dark, poor or no picture (screen lit), good sound

- Adjust PICTURE in the VIDEO menu (see "PICTURE" on page 23)
- Adjust BRIGHTNESS in the VIDEO menu (see "BRIGHTNESS" on page 23)
- Check antenna/cable connections.
- Perform AUTO SET UP again using the SET UP button to return to the factory preset condition (see "To perform AUTO SET UP again" on page 15)
- When VIDEO LABEL is set to WEB, the screen will darken, creating an ideal picture for WebTV viewing. (see "VIDEO LABEL" on page 28)

Good picture, no sound

- Press MUTING so that "MUTING" disappears from the screen. (see "MUTING" on page 16)
- Check the MTS setting in the AUDIO menu (see "MTS" on page 24)
- Make sure SPEAKER is set to ON in the AUDIO menu. (see "SPEAKER" on page 24)
- Perform AUTO SET UP again using the SET UP button to return to the factory preset condition (see "To perform AUTO SET UP again" on page 15)

Cannot receive upper channels (UHF) when using an antenna

- Make sure CABLE is OFF in the SET UP menu. (see "CHANNEL SET UP" on page 26)
- Use AUTO PROGRAM to add receivable channels that are not presently in TV memory (see "CHANNEL SET UP" on page 26)

No color

- Adjust the COLOR in the VIDEO menu. (see "COLOR" on page 23)
- Black and white programs cannot be seen in color
- Perform AUTO SET UP again using the SET UP button to return to the factory preset condition. (see "To perform AUTO SET UP again" on page 15)

Only snow and noise appear on the screen

- Check the CABLE setting in the SET UP menu (see "CHANNEL SET UP" on page 26)
- Check the antenna/cable connections
- Make sure the channel is broadcasting programs
- Press ANT to change the input mode. (see "ANT" on page 17)

Dotted lines or stripes

- Adjust the antenna
- Move the TV away from noise sources such as cars, neon signs, or hair-dryers

3 5

■ ■ ■ Troubleshooting (continued)

TV is fixed to one channel

- Try turning CHANNEL FIX off. (see "CHANNEL SET UP" on page 26)
- Use AUTO PROGRAM to add receivable channels that are not presently in the TV memory. (see "CHANNEL SET UP" on page 26)

Double images or ghosts

- Use a highly directional outdoor antenna or a cable (when the problem is caused by reflections from nearby mountains or tall buildings)

Cannot operate menu

- If the item you want to choose appears in gray, you cannot select it. Press TV/VIDEO correctly

The electronic console doors do not operate properly (KV-35XBR88 only)

- Make sure the AUTO ACCESS switch is set to ON
- Remove any dirt or dust from the ultrasonic sensor
- The clothes you are wearing may be absorbing the ultrasonic waves emitted by the sensor Try passing a different type of surface before the sensor.

Cannot receive any channels when using cable TV

- Make sure CABLE is ON in the SET UP menu (see "CHANNEL SET UP" on page 26)
- Use AUTO PROGRAM to add receivable channels that are not presently in TV memory. (see "CHANNEL SET UP" on page 26)

Cannot gain enough volume when using a cable box

- Increase the volume at the cable box. Then press TV (FUNCTION) and adjust the TV's volume.

TV malfunctions when using the S-Link function

- Make sure the TV's power cord is connected securely to the wall outlet.
- Check the S-Link connection (see "Using the S-Link function" on page 11)

CHANNEL INDEX does not display all available channels

- Make sure CABLE is ON in the SET UP menu. (see "CHANNEL SET UP" on page 26)
- Use AUTO PROGRAM to add receivable channels that are not presently in the TV memory. (see "CHANNEL SET UP" on page 26)

FAVORITE CHANNEL does not display your choices

- Verify that MODE is set to MANUAL in the FAVORITE CHANNEL menu. (see "Setting FAVORITE CHANNEL manually" on page 28)

The CUSTOMIZED MENU does not appear when you press MENU

- Verify CUSTOMIZE is set to ON in the CUSTOMIZED MENU window (see "Creating or changing a CUSTOMIZED MENU" on page 31)
- If no items are selected in the CUSTOMIZED MENU, CUSTOMIZE is set to OFF automatically. (see "Creating and changing a CUSTOMIZED MENU" on page 31)

Some video sources do not appear when you press TV/VIDEO

- Ensure that VIDEO LABEL is not set to SKIP. (see "VIDEO LABEL" on page 27)

Recording through MONITOR OUT does not function properly when recording in PIP or P&P mode

- MONITOR OUT will not record both images in PIP or P&P Only the main picture will be recorded.
- If you are recording the main picture and you switch to the sound of the sub picture using the AUDIO button, the main picture will be recorded with sound from the other program

To reset the TV to factory settings

- First, turn the TV on Then, while pressing the RESET button on the remote control, press the POWER button on the TV The TV will turn itself off, then back on When the TV turns on again, all settings will be reset, and the EASY SETUP GUIDE will appear.

3 6

SECTION 2 DISASSEMBLY

2-1. REAR COVER AND SPEAKER REMOVAL

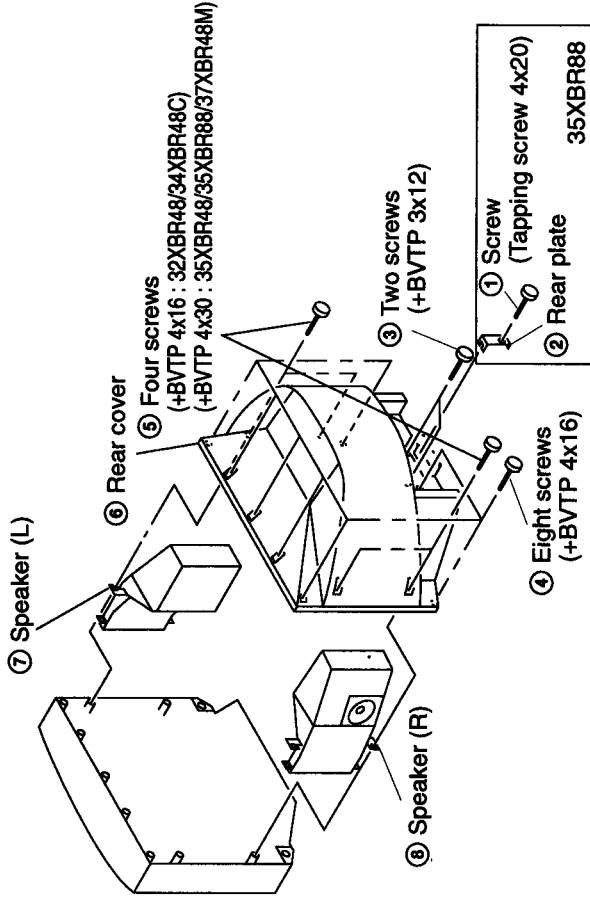

2-2-2. FA AND FB BOARDS REMOVAL (KV-35XBR88)

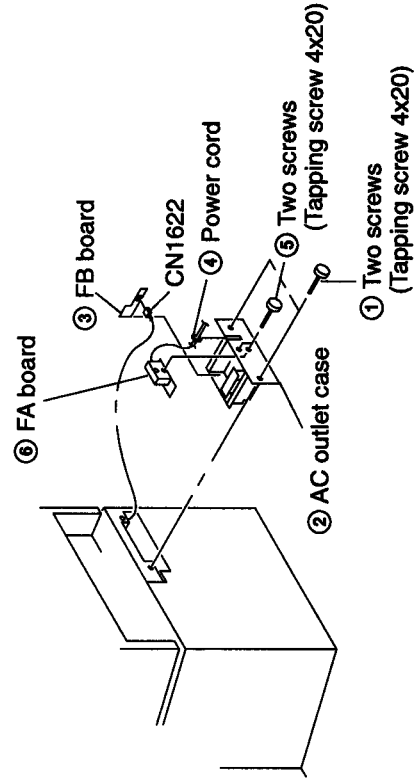

2-2-1. CABINET BASE REMOVAL (KV-35XBR88)

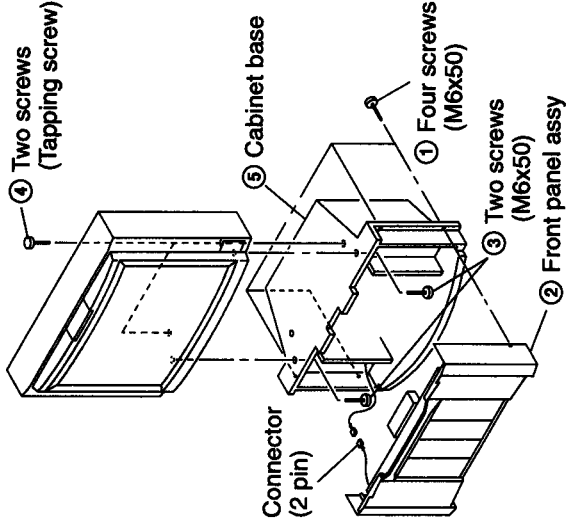

2-3. CHASSIS ASSY REMOVAL

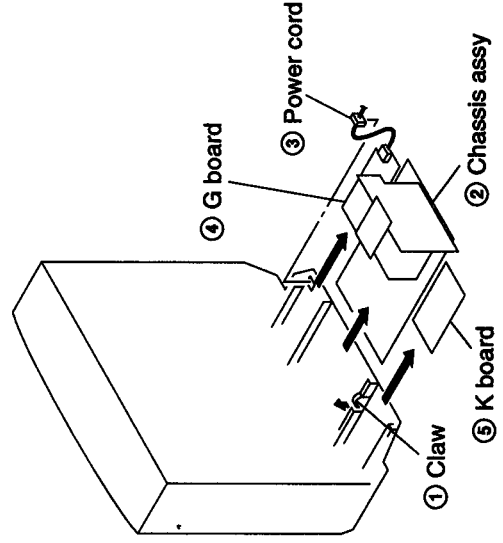

2-4. SERVICE POSITION

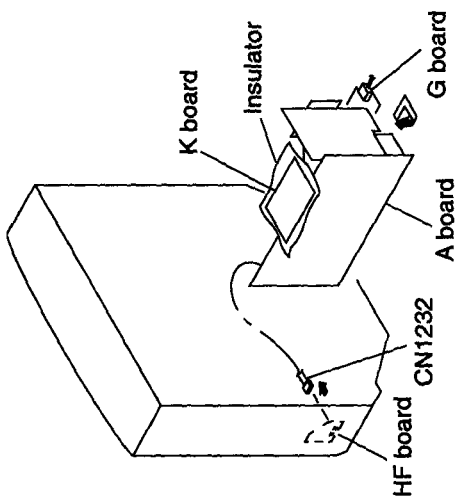

2-5. CONTROL ASSY REMOVAL

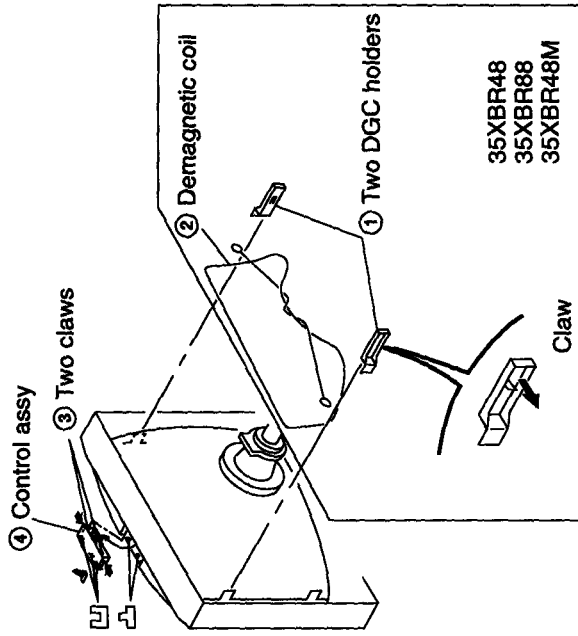

2-6. EXTENSION CABLE

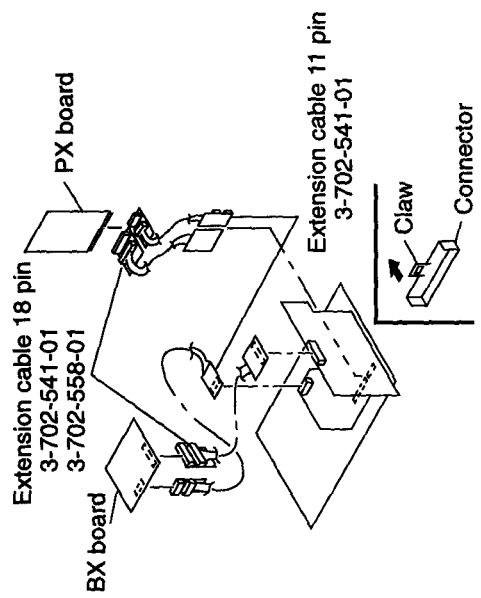

• REMOVAL OF ANODE-CAP

NOTE : Short circuit the anode of the picture tube and the anode cap to the metal chassis. CRT chield or carbon painted on the CRT, after removing the anode.

• REMOVING PROCEDURES

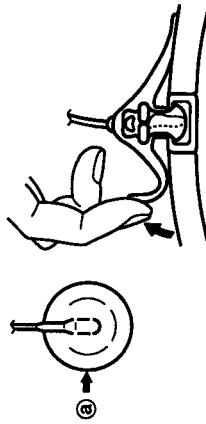

① Turn up one side of the rubber cap in the direction indicated by the arrow **a**.

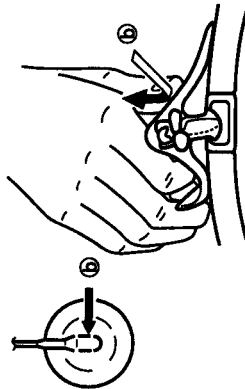

② Using a thumb pull up the rubber cap firmly in the direction indicated by the arrow **b**.

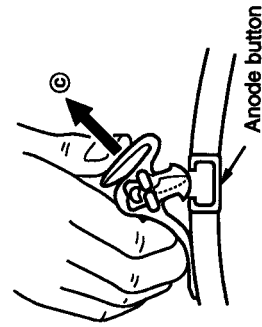

③ When one side of the rubber cap is separated from the anode button, the anode-cap can be removed by turning up the rubber cap and pulling up it in the direction of the arrow **c**.

CAUTION

Be sure to attach AC Cord to Rear Cover with the hook in the following way for after service.
Then check if the AC cord is protected against being pressed under the set.

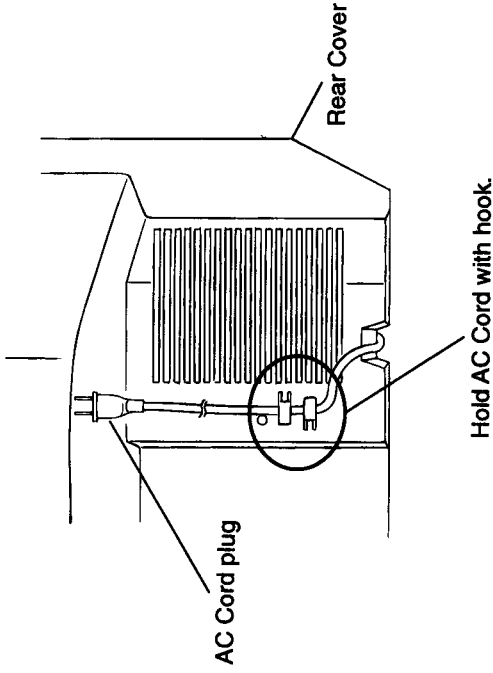

• HOW TO HANDLE AN ANODE-CAP

- ① Don't hurt the surface of anode-caps with sharp shaped material!
- ② Don't press the rubber hardly not to hurt inside of anode-caps! A material fitting called as shatter-hook terminal is built in the rubber.
- ③ Don't turn the foot of rubber over hardly! The shatter-hook terminal will stick out or hurt the rubber.

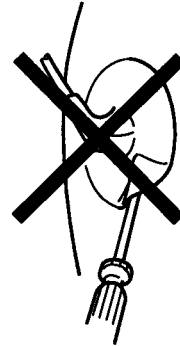
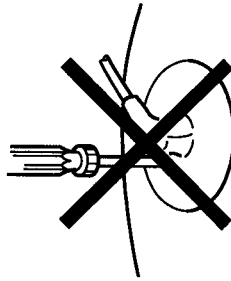

2-7. PICTURE TUBE REMOVAL

WARNING

Before removing anode cap H. V remains in the CRT even after the power is disconnected. To avoid electrical shock, before attempting to remove the anode cap, discharge CRT : short between anode and CRT coated earth ground strap.

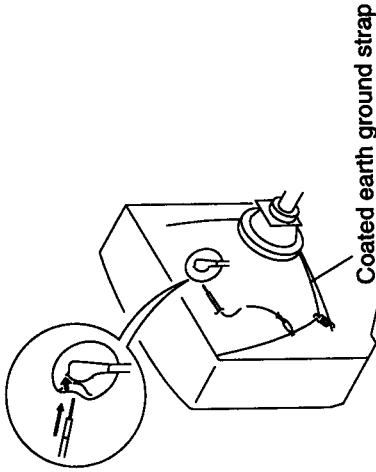

(1) KV-32XBR48/34XBR48C

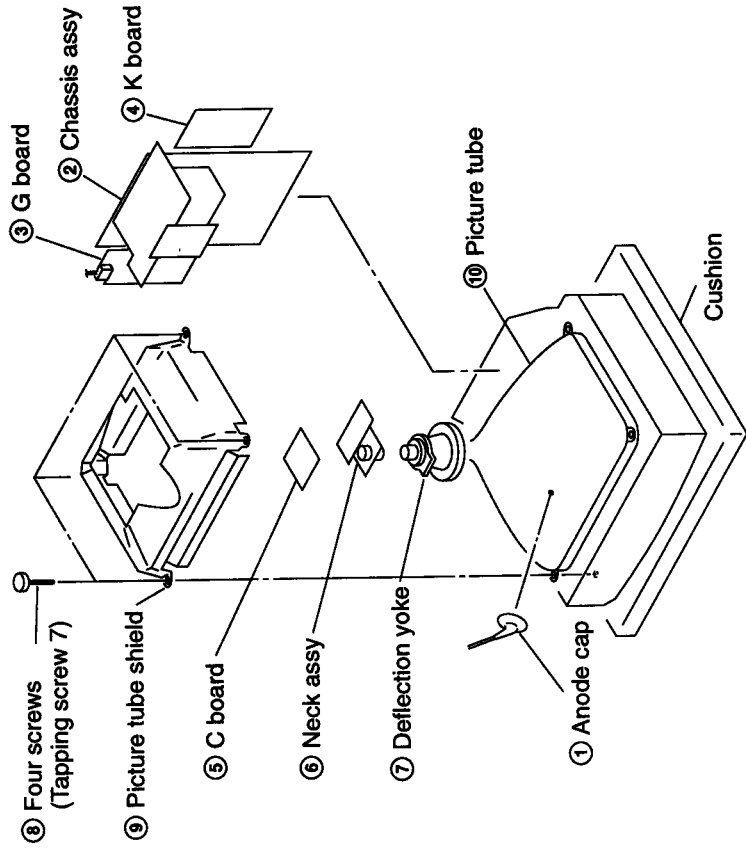

(2) KV-35XBR48/35XBR88/37XBR48M

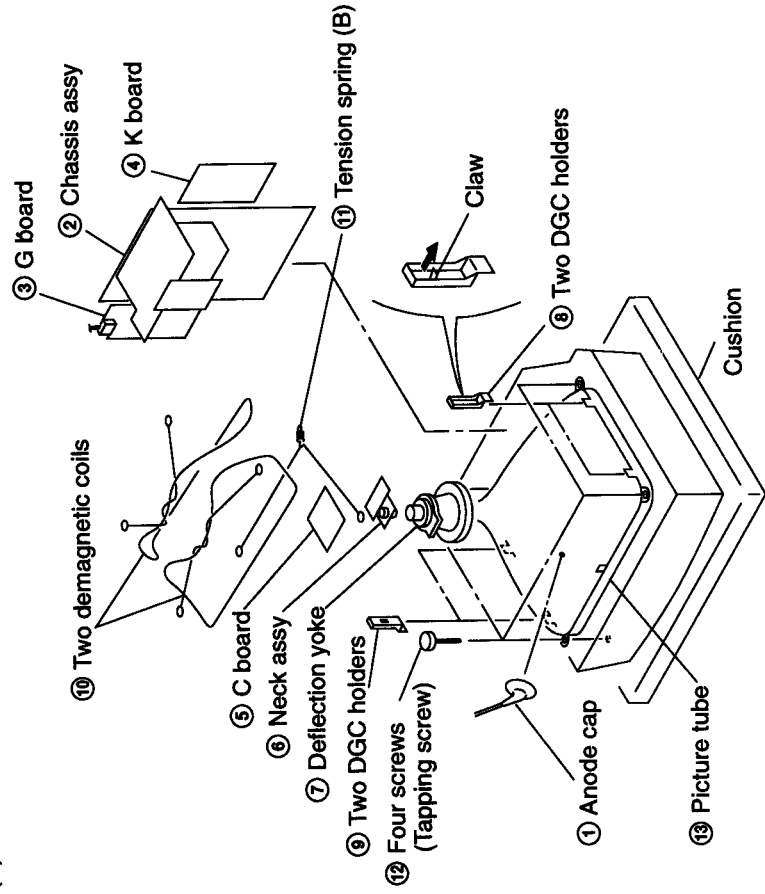

2-8. WIRE DRESSING

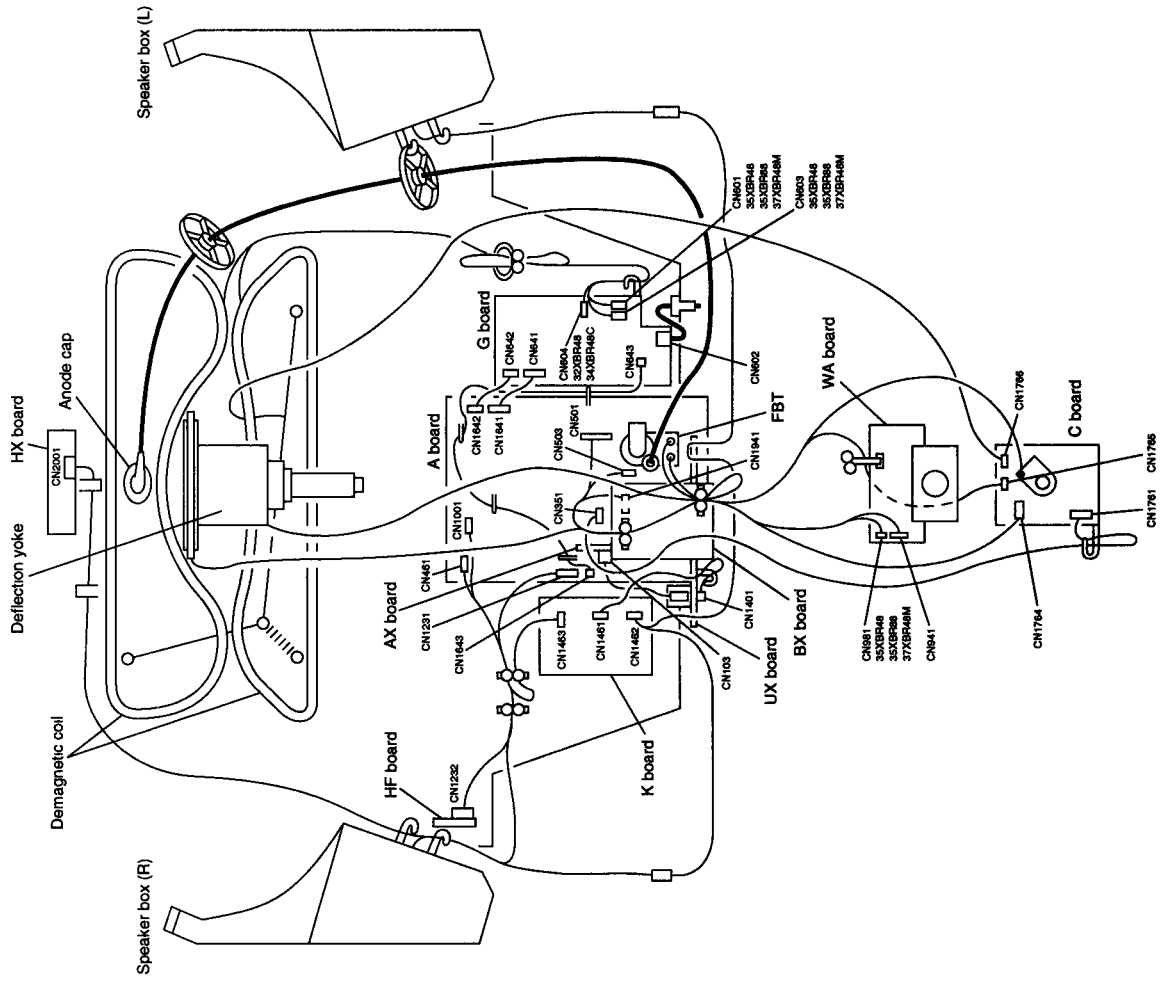

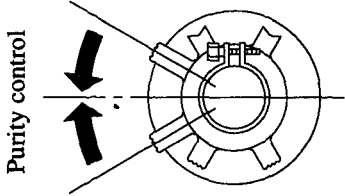
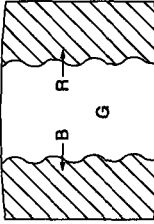
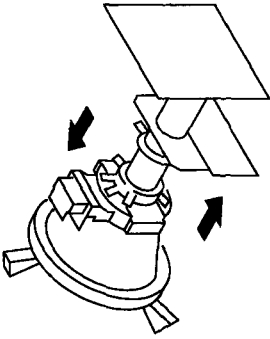

SECTION 3 SET-UP ADJUSTMENTS

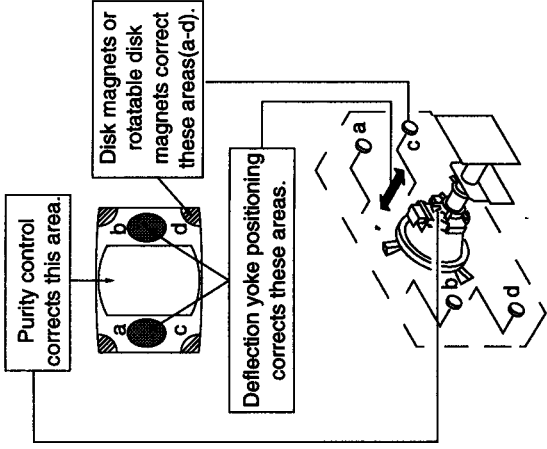

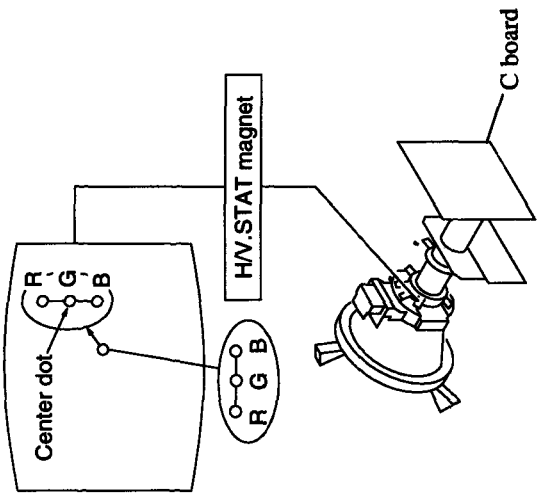
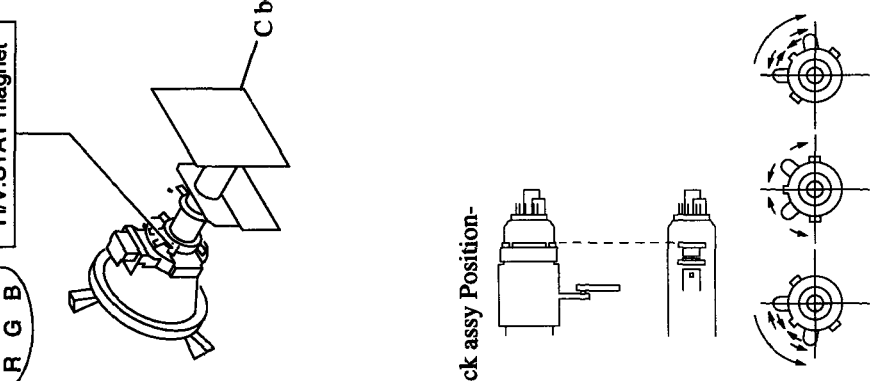
ADJUSTMENT ITEM AND PROCEDURE	EQUIPMENT AND SIGNAL	MEASUREMENT POSITION	ADJUSTMENT LOCATION	ILLUSTRATION AND SHAPE AND NUMBER
<p>● The following adjustments should be made when a complete realignment is required or a new picture tube is installed.</p> <p>● These adjustments should be performed with rated power supply voltage unless otherwise noted.</p> <p>The controls and switch should be set as follows unless otherwise noted :</p> <p>VIDEO MODE : STANDARD</p> <p>PICTURE control normal</p> <p>BRIGHTNESS control normal</p> <p>Preparation:</p> <ul style="list-style-type: none"> ● Feed in the white pattern signal. <p>(1) In order to reduce the influence of geomagnetism on the set's picture tube face it east or west.</p> <p>Note: Please do not use the hand degausser, because the hand degausser effects a spot on a CRT and magnetizes CRT around.</p>	<p>Color bar Pattern Generator</p>			  
<p>BEAM LANDING</p> <ol style="list-style-type: none"> 1. Input a *raster signal with the pattern generator. 2. Loosen the deflection yoke mounting screw, and set the *purity control to the center. 3. Turn the *raster signal of the pattern generator to green. 4. Move the *deflection yoke backward, and adjust with the purity control so that green is in the center and red and blue are at the sides evenly. 5. Move the deflection yoke forward, and adjust so that the entire screen becomes green. 	<p>*White Pattern</p> <p>*Green Pattern</p>		<p>*Purity Control</p> <p>*Deflection Yoke</p>	

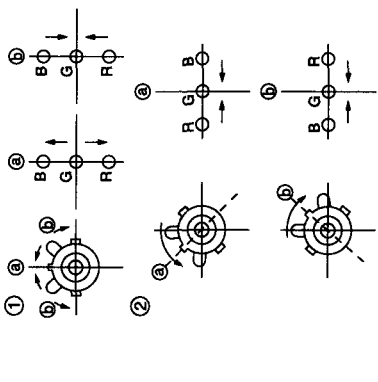
ADJUSTMENT ITEM AND PROCEDURE	EQUIPMENT AND SIGNAL	MEASUREMENT POSITION	ADJUSTMENT LOCATION	ILLUSTRATION AND SHAPE AND NUMBER
<p>6. Switch over the raster signal to red and blue and confirm the condition.</p> <p>7. When the position of the deflection yoke is determined, tighten it with the deflection yoke mounting screw.</p> <p>8. When landing at the corner is not right, adjust by using the *disk magnets.</p>			<p>*Disk Magnets</p>	

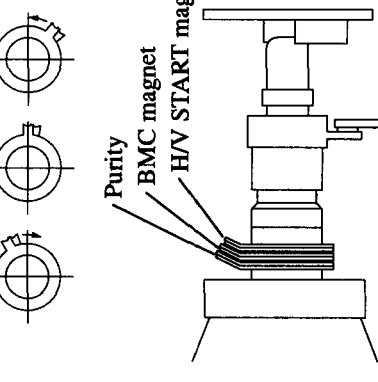
ADJUSTMENT ITEM AND PROCEDURE	EQUIPMENT AND SIGNAL	MEASUREMENT POSITION	ADJUSTMENT LOCATION	ILLUSTRATION AND SHAPE AND NUMBER
<p>CONVERGENCE</p> <p>Preparation:</p> <ul style="list-style-type: none"> ● Before starting, perform FOCUS, V. LIN and V. SIZE adjustments. ● Set BRIGHTNESS control to minimum. ● Feed in *signal. <p>(1) Horizontal and Vertical Static Convergence Adjustment</p> <p>1. Adjust *magnet to convergence red, green and blue dots in the center of the screen. (Vertical movement)</p>	<p>*Dot Pattern</p>		<p>*H/V. STAT Magnet</p>	
<p>● Tilt the *magnet and adjust static convergence to open or close the *magnet.</p>			<p>*V. STAT Magnet</p>	

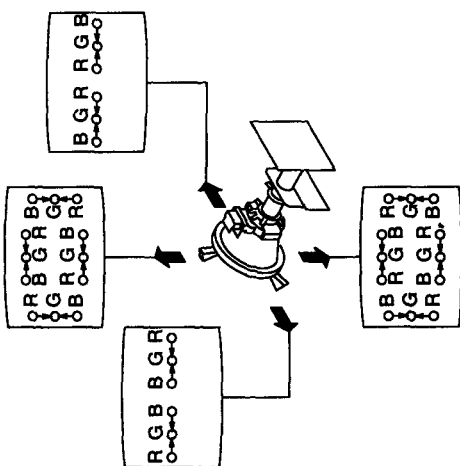
ADJUSTMENT ITEM AND PROCEDURE	EQUIPMENT AND SIGNAL	MEASUREMENT POSITION	ADJUSTMENT LOCATION	ILLUSTRATION AND SHAPE AND NUMBER
<p>2. When the *magnet is moved in the direction of arrow ③ and ⑥, red, green and blue dots move as shown below.</p>			*V. STAT Magnet	
<ul style="list-style-type: none"> ● Operation of *Magnet ● The respective dot positions resulting from moving each magnet interact, so be sure to perform adjustment while tracking. 			*BMC Magnet	
<ul style="list-style-type: none"> ● Y separation axis correction magnet adjustment <ol style="list-style-type: none"> 1. Receive a *signal, and adjust *PICTURE and BRIGHTNESS. 2. Adjust the deflection yoke to the upright condition when it hits the CRT. 3. Adjust so that the Y separation Axis correction magnet on the neck assembly is symmetrical at the top and bottom (open state). 4. Return the deflection yoke to its original position. 	* Cross-hatch Pattern		<p>* PICTURE</p> <p>..... minimum</p> <p>BRIGHTNESS</p> <p>..... normal</p>	

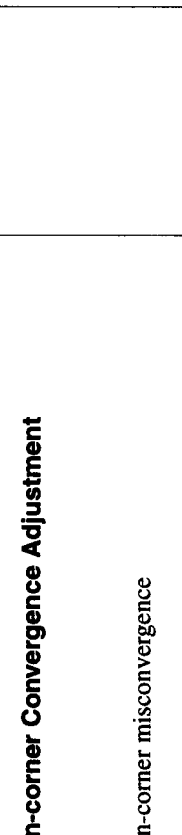
ADJUSTMENT ITEM AND PROCEDURE	EQUIPMENT AND SIGNAL	MEASUREMENT POSITION	ADJUSTMENT LOCATION	ILLUSTRATION AND SHAPE AND NUMBER
<p>(2) Dynamic Convergence Adjustment</p> <p>Preparation:</p> <ul style="list-style-type: none"> ● Before starting perform Horizontal and Vertical static convergence Adjustment. 1. Slightly loosen deflection yoke screw. 2. Remove deflection yoke spacers. 3. Move the *deflection yoke for best convergence as shown below. 4. Tighten the deflection yoke screw. 5. Install the deflection yoke spacers. 			<p>*Deflection Yoke</p>	 <p>The diagram shows a central deflection yoke assembly with four arrows pointing to specific adjustment points. Each point is labeled with a color-coded box containing a sequence of letters and symbols. The boxes are: <ul style="list-style-type: none"> Top-left: RGB BGR Top-right: BGR RGB Bottom-left: RBGR GB Bottom-right: BRGB GR Each box contains a sequence of letters (R, G, B) and a symbol (a circle with a dot) arranged in a specific pattern.</p>

ADJUSTMENT ITEM AND PROCEDURE	EQUIPMENT AND SIGNAL	MEASUREMENT POSITION	ADJUSTMENT LOCATION	ILLUSTRATION AND SHAPE AND NUMBER
<p>(3) Screen-corner Convergence Adjustment</p> <p>a-b : screen-corner misconvergence</p> <p>Affix a Permalloy ass'y corresponding to the misconverged areas</p>			<p>*SCREEN control (On FBT Ass'y)</p> <p>Permalloy Ass'y</p>	
<p>FOCUS</p> <p>Adjust *FOCUS control for best picture.</p>			<p>*FOCUS control (On FBT Ass'y)</p>	
<p>SCREEN (G2)</p> <ol style="list-style-type: none"> 1. Input a *signal. 2. Adjust *PICTURE, BRIGHTNESS controls. 3. Adjust S BRT, G CUT, B CUT in service mode so that voltages on the red, green and blue *cathodes are *Voltage with an oscilloscope. 4. Observe the screen and adjust *SCREEN (G2)VR On FBT (Flyback transformer ass'y) to obtain the faintly visible background of dot signal. 	<p>*Dot pattern</p> <p>Oscilloscope</p>	<p>*cathodes</p>	<p>*PICTURE normal</p> <p>*BRIGHTNESS normal</p> <p>*S BRT</p> <p>*G CUT</p> <p>*B CUT</p> <p>*SCREEN (G2) (On FBT Ass'y)</p>	<p>*170 ± 2 V DC</p> 

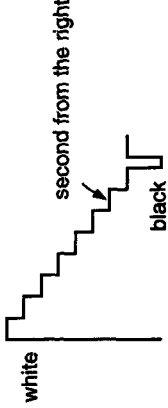
ADJUSTMENT ITEM AND PROCEDURE	EQUIPMENT AND SIGNAL	MEASUREMENT POSITION	ADJUSTMENT LOCATION	ILLUSTRATION AND SHAPE AND NUMBER																										
<p>WHITE BALANCE ADJUSTMENTS</p> <table border="1" data-bbox="277 1459 520 1990"> <thead> <tr> <th rowspan="2">Disp.</th> <th rowspan="2">Item</th> <th colspan="2">Ave. Data</th> </tr> <tr> <th>32"/34"</th> <th>35"/37"</th> </tr> </thead> <tbody> <tr> <td>VP</td> <td>Green Drive</td> <td>38</td> <td>37</td> </tr> <tr> <td></td> <td>Blue Drive</td> <td>36</td> <td>33</td> </tr> <tr> <td></td> <td>Green Cut-off</td> <td>12</td> <td>11</td> </tr> <tr> <td></td> <td>Blue Cut-off</td> <td>10</td> <td>9</td> </tr> <tr> <td></td> <td>Sub Bright</td> <td>28</td> <td>24</td> </tr> </tbody> </table> <ol style="list-style-type: none"> 1. Input a *signal. 2. Set to service adjustment mode. 3. Set the PICTURE and BRIGHTNESS to *adjustment. 4. Adjust with *S BRT if necessary. 5. Select *G CUT and *B CUT with [1] and [4]. 6. Adjust with [3] and [6] for the best white balance. 7. Set the *PICTURE and BRIGHTNESS to *adjustment. 8. Select *G AMP and B AMP with [1] and [4]. 9. Adjust with [3] and [6] for the best white balance. 10. Write into the memory by pressing MUTING then ENTER. 	Disp.	Item	Ave. Data		32"/34"	35"/37"	VP	Green Drive	38	37		Blue Drive	36	33		Green Cut-off	12	11		Blue Cut-off	10	9		Sub Bright	28	24	<p>*Entire White Pattern</p>		<p>*PICTURE minimum BRIGHTNESS minimum *S BRT *G CUT *B CUT *PICTURE maximum BRIGHTNESS maximum *G AMP B AMP</p>	
Disp.			Item	Ave. Data																										
	32"/34"	35"/37"																												
VP	Green Drive	38	37																											
	Blue Drive	36	33																											
	Green Cut-off	12	11																											
	Blue Cut-off	10	9																											
	Sub Bright	28	24																											
<p>SUB BRIGHT ADJUSTMENT</p> <ol style="list-style-type: none"> 1. Set to service adjustment mode. 2. Input a *signal. 3. Select SBRT with [1] and [4], and adjust SUB BRIGHT level with [3] and [6] so that the stripe second from the right is dimly lit. 4. Write into the memory by pressing MUTING then ENTER. 	<p>* Grey scale pattern</p>		<p>*PICTURE minimum BRIGHTNESS normal SBRT</p>																											

ELECTRICAL ADJUSTMENTS BY REMOTE COMMANDER

Use of Remote Commander (RM-Y144) can be performed circuit adjustments about this model.

NOTE : Test Equipment Required.

1. Pattern Generator
2. Frequency counter
3. Digital multimeter
4. Audio OSC

1. METHOD OF SETTING THE SERVICE ADJUSTMENT MODE

SERVICE MODE PROCEDURE

1. Standby mode. (Power off)
2. **DISPLAY** → **5** → **VOL(+)** → **POWER** on the Remote Commander. (Press each button within a second.)

SERVICE ADJUSTMENT MODE IN

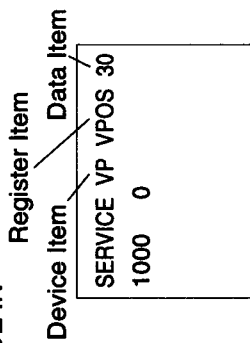

3. The CRT displays the item Being adjusted.
4. Press **2** or **5** on the Remote Commander to select the device item.
5. Press **1** or **4** on the Remote Commander to select the item.
6. Press **3** or **6** on the Remote Commander to change the data.
7. If you want to recover the latest values press **0** then **ENTER** to lead the memory.
8. Press **MUTING** then **ENTER** to write into memory.

SERVICE ADJUSTMENT MODE MEMORY

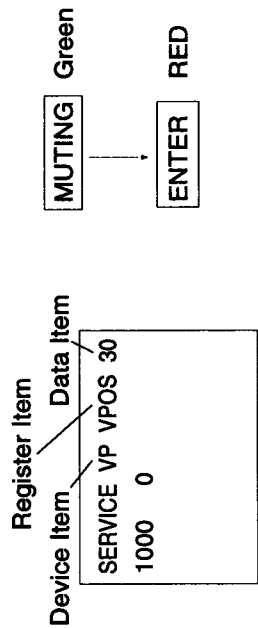

8. Press **8** then **ENTER** on the Remote Commander to reset.

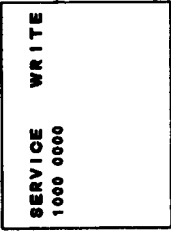

Carry out step 8) when adjusting IDs 0 to 4 and when replacing and adjusting IC102.

Factory original setting

9. Turn set off and on to exit.

2. MEMORY WRITE CONFIRMATION METHOD

1. After adjustment, pull out the plug from AC outlet, and next place, plug in AC outlet again.
2. Turn the power switch ON and set to Service Mode.
3. Call the adjusted items again, confirm they were adjusted.

3. ADJUST BUTTONS AND INDICATOR

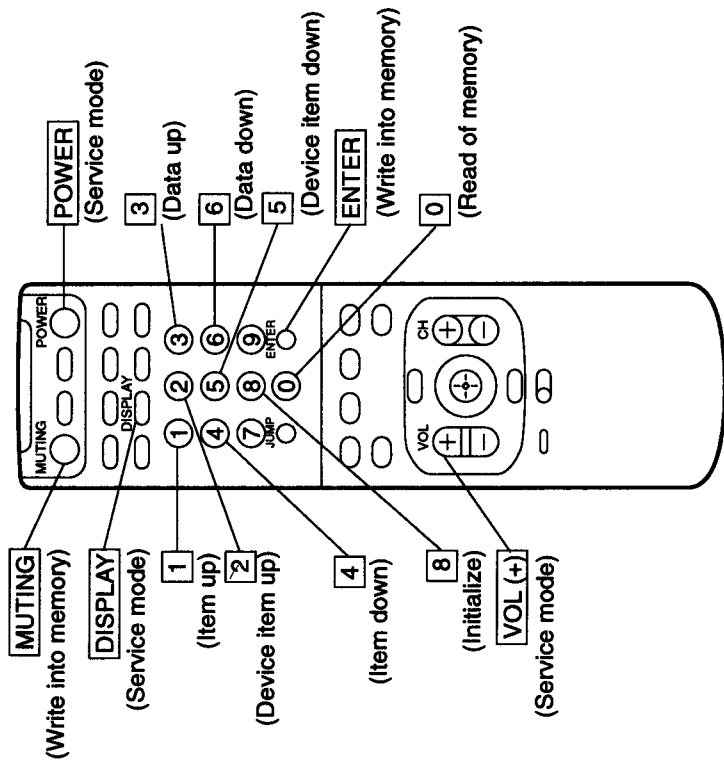

SERVICE DATA

VP	Discriptions	Device	Resistor Name	Data Length	Initial Data	Average Data		Comment
						32°/34°	35°/37°	
VP	VPOS	CXA2025S	V-Position	0-63	20	23	12	Adjust
	VSIZ		V-Size	0-63	20	34	37	Adjust
	VCOM		V-Compensation	0-3	1	1	1	Adjust
	VLIN		V-Linearity	0-15	7	8	7	Adjust
	VSCO		S-Correction	0-15	7	7	7	Adjust
	HPOS		H-Position	0-15	7	10	12	Adjust
	Hsiz		H-Size	0-63	20	36	36	Adjust
	PAMP		PIN-Compensation	0-63	31	28	27	Adjust
	UPIN		Upper-CornerPin	0-15	7	7	7	Adjust
	LPIN		Lower-CornerPin	0-15	7	7	7	Adjust
	PPHA		Pin-Phase	0-15	7	5	5	Adjust
	AFC		AFC	0-3	2	2	2	Adjust
	VBOW		AFC-Bow	0-15	7	5	6	Adjust
	VANG		AFC-Angle	0-15	7	8	7	Adjust
	REF		Reference-Position	0-3	2	1	2	Adjust
	GDRV		Green-Drive	0-63	31	38	37	Adjust
	BDRV		Blue-Drve	0-63	31	36	33	Adjust
	GCUT		Green-Cutoff	0-15	7	12	11	Adjust
	BCUT		Blue-Cutoff	0-15	7	10	9	Adjust
	SCON		Sub-Contrast	0-15	7	9	10	Adjust
	SHUE		Sub-Hue	0-15	7	4	2	Adjust
	SCOL		Sub-Color	0-15	7	6	6	Adjust
	SBRT		Sub-Brightness	0-63	31	28	24	Adjust
	SSHP		Sub-Sharpness	0-15	7	7	7	Adjust
	CDM2		Countdown Mode 2	0-1	1	1	0	Adjust
	DPIX		Dynamic-Picture	0,1	1	1	1	Adjust
	Y-DC		DC-Transmission	0,1	1	1	1	Adjust
	ABLM		ABL	0,1	1	1	1	Adjust
	NOTC		Chroma Trap	0,1	0	0	0	Adjust
	CROM		Chroma Trap-Adjust	0-15	7	7	7	Adjust
	TOT		TOT-Filter	0,1	1	1	1	Adjust
	PREL		Pre/Over-Shoot	0-3	3	0	0	Adjust
	SHIPF		Sharpness-f0	0-3	2	2	2	Adjust
	RON		Red-Off	0,1	1	1	1	Adjust
	GON		Green-Off	0,1	1	1	1	Adjust
	BON		Blue-Off	0,1	1	1	1	Adjust
CDMD	V-Countdown	0,1	0	0	0	Adjust		
HBSW	H Blanking Switch	0,1	1	0	0	Adjust		
LBLK	Left Blanking	0-15	2	7	7	Adjust		
RBLK	Right Blanking	0-15	7	7	7	Adjust		
SVOL	Sub-Volume	0-15	0	0	0	Adjust		
SBAL	Sub-Balance	0-15	7	7	7	Adjust		
AP		BH3856FS						

Discriptions	Device	Resistor Name	Data Length	Initial Data	Average Data		Comment
					32'34"	35'37"	
SBAS	μPD6488	Sub-Bass	0-15	7	4	7	Adjust
STRE		Sub-Treble	0-15	7	5	7	Adjust
CGAN		CGAIN	0,1	1	1	1	Adjust
AVAP		AVAPON	0,1	1	1	1	Adjust
MS		MS0/MS1	0-2	0	0	0	Adjust
YDLL		YDELAY-L	0-7	2	2	2	Adjust
HRD8		HRD08	0,1	0	0	0	Adjust
HRD7		HRD00-07	0-255	12	12	12	Adjust
DYCO		DYCOR	0-15	5	5	5	Adjust
DYGA		DYGAIN	0-15	8	8	8	Adjust
DCCO		DCCO	0-15	3	3	3	Adjust
DCCG		DCCAIN	0-15	7	7	7	Adjust
VTR0		VTR0/VTR1	0-2	0	0	0	Adjust
VTRH		VTRH	0-2	2	2	2	Adjust
VTRR		VTRR	0-15	7	7	7	Adjust
SELJ		SELJ	0,1	1	1	1	Adjust
HSDR		HSDR	0-15	7	7	7	Adjust
WSCO		WSCOR	0-15	15	15	15	Adjust
LSDR		LDSREF	0-15	7	7	7	Adjust
WSD1		WSDR1	0-15	15	15	15	Adjust
WSD2		WSDR2	0-15	15	15	15	Adjust
VAPG		VAPGAIN	0-7	4	4	4	Adjust
VAPI		VAPINV	0-31	15	15	15	Adjust
MOTE		MDTES	0,1	0	0	0	Adjust
YTM8		YTM87	0,1	0	0	0	Adjust
DYTR		DYTRAP	0,1	1	1	1	Adjust
VHG		VHG	0-3	3	3	3	Adjust
YH87		YH87	0,1	0	0	0	Adjust
YSG		YSG	0,1	1	1	1	Adjust
YTG		YTG	0-3	1	1	3	Adjust
VTMR		VTMREF	0-15	12	12	12	Adjust
VHRE		VHREF	0-15	11	11	11	Adjust
YT1R		YT1REF	0-15	2	2	2	Adjust
CT2Y	CT2YT	0,1	0	0	0	Adjust	
CTG	CTG	0-3	1	1	1	Adjust	
CTMR	CTMREF	0-15	10	10	10	Adjust	
CT2R	CT2REF	0-15	10	10	10	Adjust	
CT1R	CT1REF	0-15	7	7	7	Adjust	
SHPR	Sharpness	0-127	59	59	59	Adjust	
SRTS	SRT Start Position	0,1	3	3	3	Adjust	
GIRE	Gamma Start Point	0-3	3	3	3	Adjust	
GCUR	Gamma Curve	0,1	0	0	0	Adjust	
RS	RS	0-7	0	0	0	Adjust	
RTC	RTC	0-7	4	4	4	Adjust	

TA1226N

PI

PP	Discriptions	Device	Resistor Name	Data Length	Initial Data	Average Data		Comment		
						32"/34"	35"/37"			
PP	SMT6	SAB9076	SMART6	0, 1	1	1	1	Adjust		
	SKIP6		SKIP6	0, 1	0	0	0	Adjust		
	BGHP		BGHP	0-15	9	7	6	Adjust		
	BGVP		BGVP	0-15	8	8	6	Adjust		
	MAHP		MAHP	0-15	7	6	5	Adjust		
	MAVP		MAVP	0-255	24	24	24	Adjust		
	SAHP		SAHP	0-15	3	3	3	Adjust		
	SAVP		SAVP	0-255	24	24	24	Adjust		
	VPED		VPED	0-15	0	0	0	Adjust		
	UPED		UPED	0-15	0	0	0	Adjust		
	MDEC		MDEC	16h , bit0-4	18	18	18	Adjust		
	SDEC		SDEC	15h , bit0-4	16	16	16	Adjust		
	DISS		DISS	17h , bit0-7	2	2	2	Adjust		
	BSIZ		BSIZ	---	34	34	34	Adjust		
	POFH		POFH	---	11	11	11	Adjust		
	POFV		POFV	---	6	6	6	Adjust		
	DHPS		DHPS	Display H Position Start	3	3	3	Adjust		
	P&PV		P&PV	SDhfp , MDhfp under P&P	62	62	62	Adjust		
	BBR0		BBR0	---	1	1	1	Adjust		
	BCL0		BCL0	---	7	7	7	Adjust		
	BBR2		BBR2	---	2	2	2	Adjust		
	BCL2		BCL2	---	6	6	6	Adjust		
	BBR3		BBR3	---	0	0	0	Adjust		
	BCL3		BCL3	---	7	7	7	Adjust		
	MC		MHUE	CXA2019	HUE	0-63	26	26	26	Adjust
			MCOL		COLOR	0-63	38	35	35	Adjust
			MSCO		SUB CONT	0-15	7	7	6	Adjust
			MSCL		SUB COLOR	0-15	7	7	5	Adjust
			MSHU		SUB HUE	0-15	7	7	9	Adjust
			MTOT		TOT ON	0, 1	1	1	1	Adjust
			MTRP		TRAP ON	0, 1	0	0	0	Adjust
			MTRA		CTRAPADJ	0-15	7	7	7	Adjust
			MCD2		CD MODE2	0, 1	1	1	1	Adjust
			MFSC		FSC OUT	0, 1	1	1	1	Adjust
			MYDR		Y DRIVE	0-31	24	22	22	Adjust
MVPE		V PED	0-15		7	7	8	Adjust		
MUPE		U PED	0-15		7	7	6	Adjust		
MRVP		RV PED	0-15		7	7	7	Adjust		
MRUP		RU PED	0-15		7	7	7	Adjust		
MDC1		DC TRAN	0-7		0	0	0	Adjust		
MRVD		RY DRIVE	0-31		31	31	31	Adjust		
MPRE		PRE OVER	0-3		0	0	0	Adjust		
MRUD		RU DRIVE	0-31		15	15	15	Adjust		

Discriptions	Device	Resistor Name	Data Length	Initial Data	Average Data		Comment
					32"/34"	35"/37"	
MRVD	CXA2019	RV DRIVE	0-31	15	15	15	Adjust
MDLY		DELAY	0-3	0	0	0	Adjust
MSCR		SCP BGR	0-3	1	1	1	Adjust
MSCF		SCP BGF	0-3	1	1	1	Adjust
ICYC		CV/YC	0,1	1	1	1	Adjust
IHUE		HUE	0-63	24	24	24	Adjust
ICOL		COLOR	0-63	37	37	37	Adjust
ISCO		SUB CONT	0-15	7	6	5	Adjust
ISCL		SUB COLOR	0-15	7	7	4	Adjust
ISHU		SUB HUE	0-15	7	7	9	Adjust
ITOT		TOT ON	0,1	1	1	1	Adjust
ITRP		TRAP ON	0,1	0	0	0	Adjust
ITRA		CTRAPADJ	0-15	7	7	7	Adjust
ICD2		CD MODE2	0,1	1	1	1	Adjust
IYDR		Y DRIVE	0-31	26	24	24	Adjust
IVPE		V PED	0-15	7	7	7	Adjust
IUPE		U PED	0-15	7	7	5	Adjust
IRVP		RV PED	0-15	7	7	7	Adjust
IRUP		RU PED	0-15	7	7	7	Adjust
IDCT		DC TRAN	0-7	0	0	0	Adjust
IRYD	RY DRIVE	0-31	31	31	31	Adjust	
IPRE	PRE OVER	0-3	0	0	0	Adjust	
IRUD	RU DRIVE	0-31	15	15	15	Adjust	
IRVD	RV DRIVE	0-31	15	15	15	Adjust	
IDLY	DELAY	0-3	0	0	0	Adjust	
ISCR	SCP BGR	0-3	1	1	1	Adjust	
ISCF	SCP BGF	0-3	1	1	1	Adjust	
DA	CXA1315	DAC0 (Rotation Coil)	0-63	32	32	32	Adjust
		DAC1 (CXA2039 Hue)	0-63	32	(24)	32	Adjust
		DAC2 (CXA2039 COL)	0-63	32	(31)	32	Adjust
CC	CXP85656A-001S		0-15	9	9	9	Fixed Value Only
			0-15	2	2	2	Fixed Value Only
			0-15	5	5	5	Fixed Value Only
			0-7	3	3	3	Fixed Value Only
			0-7	4	4	4	Fixed Value Only
			0-3	1	1	2	Fixed Value Only
			0-3	3	3	3	Fixed Value Only
			0-7	4	4	4	Fixed Value Only
			0-15	4	4	4	Fixed Value Only
			0-63	7	7	7	Fixed Value Only
			0-256	142	142	142	Fixed Value Only
			0-256	186	186	186	Fixed Value Only
			0-15	8	8	8	Fixed Value Only

Discriptions	Device	Resistor Name	Data Length	Initial Data	Average Data		Comment
					32"34"	35"37"	
CRFD			0-15	9	9	9	Fixed Value Only
CSSD			0-15	3	3	3	Fixed Value Only
CSED			0-15	9	9	9	Fixed Value Only
CSBS			0-31	12	12	12	Fixed Value Only
GDSD			0-31	8	8	8	Fixed Value Only
CCDS			0-31	9	9	9	Fixed Value Only
CHMK			0-63	42	42	42	Fixed Value Only
CHSY			0-255	136	136	136	Fixed Value Only
OP	CXP85856A-001S	OSD Position	0-63	1	(38)	23	0 : Not Available , 1 : Left , 63 : Right
PDPS		PIP Display Position Start	0-63	1	(35)	36	0 : Not Available , 1 : Left , 63 : Right
PDP0		PIP Display Position 0	0-3	0	(1)	1	Shift to Right by 1 font
PDP1		PIP Display Position 1	0-7	0	(4)	4	Shift to Right by 1 font
PDP2		PIP Display Position 2	0-7	0	(4)	4	Shift to Right by 1 font
KILS		Color Killer SW	0, 1	1	1	1	0 : Not Available , 1 : Available
ID	ID	ID-0	0-255	25	25	25	fix
		ID-1	0-255	63	63	63	fix
		ID-2	0-255	47	47	47	fix
		ID-3	0-255	0	0	0	fix
		ID-4	0-255	155	155	155	32"34" : 27 , 35"37" : 155
		ID-5	0-255	143	143	143	fix
		ID-6	0-255	6	6	6	fix
		ID-7	0-255	32	32	32	fix

Fix

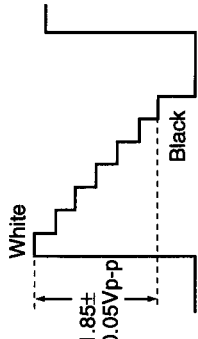
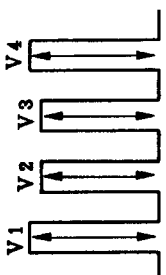
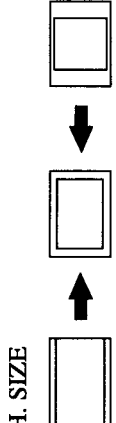
ADJUSTMENT ITEM AND PROCEDURE	EQUIPMENT AND SIGNAL	MEASUREMENT POSITION	ADJUSTMENT LOCATION	ILLUSTRATION AND SHAPE AND NUMBER
<p>SUB CON ADJUSTMENT (SCON)</p> <ol style="list-style-type: none"> 1. Input a *signal. 2. Set COLOR = min, PICTURE = max. " G " = " 0 " (OFF), " R " = " 0 " (OFF). 3. Set to Service adjustment Mode and Connect an *oscilloscope pin ① of CN351. 4. Select " SCON " with [1] and [4]. 5. Adjust with [3] and [6] for the $1.85 \pm 0.05V_{p-p}$ of level. 6. Write into the memory by [MUTING] then [ENTER]. 	<p>* 75% Color-bar pattern</p>	<p>*CN351 Pin ①</p>		<p>ILLUSTRATION AND SHAPE AND NUMBER</p> 
<p>SUB HUE, SUB COLOR ADJUSTMENT (SHUE, SCOL)</p> <ol style="list-style-type: none"> 1. Input a *signal. 2. Set to service adjustment Mode and set to picture = max, color = standard. 3. Connect an *oscilloscope *Connector Pin (B OUT) of C board. 4. Select SHUE and SCOL with [1] and [4]. 5. Adjust with [3] and [6] for the $V1 = V4$ (SCOL) and $V2 = V3$ (SHUE). 6. After adjust write SCOL and SHUE data 1 step down. 7. Write into the memory by pressing [MUTING] then [ENTER]. 	<p>* Color-bar pattern * Oscilloscope</p>	<p>*CN351 Pin ③</p>		
<p>H SIZE ADJUSTMENT (HSIZ)</p> <ol style="list-style-type: none"> 1. Input a *signal. 2. Set to Service adjustment Mode. 3. Select HSIZ with [1] and [4]. 4. Adjust with [3] and [6] for the best Horizontal size. 5. Write the memory by pressing [MUTING] then [ENTER]. 	<p>* Color-bar pattern</p>	<p>HSIZ</p>		

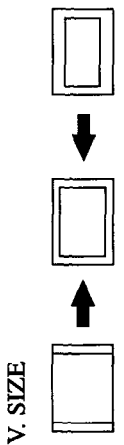
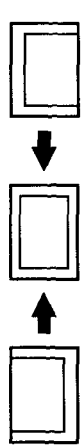
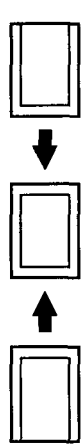
ADJUSTMENT ITEM AND PROCEDURE	EQUIPMENT AND SIGNAL	MEASUREMENT POSITION	ADJUSTMENT LOCATION	ILLUSTRATION AND SHAPE AND NUMBER
<p>V. SIZE ADJUSTMENT (VSIZ)</p> <ol style="list-style-type: none"> 1. Input a *signal. 2. Set to service adjustment Mode. 3. Select VSIZ with [1] and [4]. 4. Adjust with [3] and [6] for the best vertical size. 5. Write into the memory by pressing [MUTING] then [ENTER]. 	*Cross-hatch pattern		VSIZ	 <p>V. SIZE</p>
<p>V. POSITION ADJUSTMENT (VPOS)</p> <ol style="list-style-type: none"> 1. Input a *signal. 2. Set to service adjustment Mode. 3. Select VPOS with [1] and [4]. 4. Adjust with [3] and [6] for the best vertical center. 5. Write into the memory by pressing [MUTING] then [ENTER]. 	*Cross-hatch pattern		VPOS	 <p>V. POSITION</p>
<p>H. POSITION ADJUSTMENT (H POS)</p> <p>Note : Perform this adjustment after H. FREQUENCY ADJUSTMENT (HFRE).</p> <ol style="list-style-type: none"> 1. Input a *signal. 2. Set the Service adjustment Mode. 3. Select HPOS with [1] and [4]. 4. Adjust with [3] and [6] for the best horizontal center. 5. Write into the memory by pressing [MUTING] then [ENTER]. 	*Cross-hatch pattern		HPOS	 <p>H. POSITION</p>

ADJUSTMENT ITEM AND PROCEDURE	EQUIPMENT AND SIGNAL	MEASUREMENT POSITION	ADJUSTMENT LOCATION	ILLUSTRATION AND SHAPE AND NUMBER
<p>V LINEARITY (VLIN), V CORRECTION (VSCO), PIN AMP (PAMP), AND PIN PHASE (PPHA) ADJUSTMENTS</p> <ol style="list-style-type: none"> 1. Input a *signal. 2. Set to Service adjustment Mode. 3. Select VLIN, VSCO, PAMP, and PPHA with [1] and [4]. 4. Adjust with [3] and [6] for the best picture. 5. Write the memory by Pressing [MUTING] then [ENTER]. 	<p>*Cross-hatch pattern</p>		<p>VLIN VSCO PAMP PPHA VANG VBOW UPIN LPIN</p>	

SECTION 4 SAFETY RELATED ADJUSTMENTS

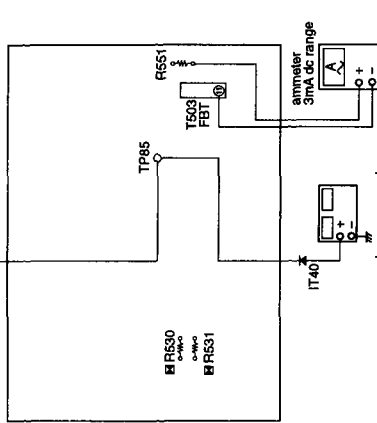
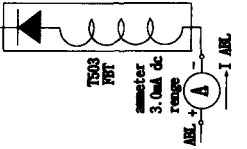
ADJUSTMENT ITEM AND PROCEDURE	EQUIPMENT AND SIGNAL	MEASUREMENT POSITION	ADJUSTMENT LOCATION	ILLUSTRATION AND SHAPE AND NUMBER
<p>RESISTOR CONFIRMATION METHOD (HOLD-DOWN CONFIRMATION) AND READJUSTMENTS</p> <p>The following adjustments should always be performed when replacing the following components (*marked with <input checked="" type="checkbox"/> on the schematic diagram). (Hold-down operation confirmation)</p>	<p>* marked parts IC643, IC351, IC501 D519, D520, D521, C531, C532, R387, R529, R530, R531 R532, R533, R550, R661 T503</p>	<p>* <input checked="" type="checkbox"/> R530, 531</p>	<p>* VIDEO MODE : STANDARD PICTURE BRIGHTNESS maximum</p>	<p>A BOARD - CONDUCTOR SIDE</p>  <p>[Check Condition] Step 1 *32" : more than 21.5V DC 35" : more than 18.0V DC *120 ± 2.0 VAC (Power Supply)</p>
<p>Step 1</p> <p>1. Preparation before confirmation</p> <p>1) Turn the POWER switch ON, and receive *signal and set the *PICTURE and BRIGHTNESS controls to adjustment.</p> <p>2) Confirm that the voltage of the check terminal of *TP is more than *voltage when the set is operating normally with *Power supply.</p>	<p>* White Picture</p> <p>* Digital multimeter</p>	<p>* TP85 (H. PROT)</p>	<p>* VIDEO MODE : STANDARD PICTURE BRIGHTNESS maximum</p>	<p>[Check Condition] Step 2 *IABL 32" : 2000 ± 100 μA 35" : 2160 ± 100 μA *120 ± 2.0 V AC (Power Supply)</p>
<p>Step 2</p> <p>2. Confirm that a voltage of between TP85 and ground.</p>	<p>* White Picture</p>		 <p>Connect an Ammeter to the location of R531 space. After the current measurement, put back the resistor.</p> <p>* VIDEO MODE : STANDARD PICTURE BRIGHTNESS maximum</p>	<p>[Check Condition] Step 3 *32" : lower than 26.95V DC 35" : lower than 22.05V DC *120 ± 2.0 V AC (Power Supply)</p>
<p>Step 3</p> <p>3. Using an external DC power supply, apply voltage between TP 85 and ground. Increase gradually the voltage and confirm that the hold-down works (Raster disappears) at lower than the voltage obtained Step 2 mentioned above *voltage.</p> <p>Step 4</p> <p>4. Confirm that a voltage of more than *voltage appears TP85 and ground.</p>	<p>* White Picture</p>		<p>[Check Condition] Step 4 *32" : more than 21.5V DC 35" : more than 18.0V DC *120 ± 2.0 V AC (Power Supply)</p>	<p>[Check Condition] Step 4 *32" : more than 21.5V DC 35" : more than 18.0V DC *120 ± 2.0 V AC (Power Supply)</p>

ADJUSTMENT ITEM AND PROCEDURE	EQUIPMENT AND SIGNAL	MEASUREMENT POSITION	ADJUSTMENT LOCATION	ILLUSTRATION AND SHAPE AND NUMBER
<p>B+ VOLTAGE CONFIRMATION</p> <p>The following adjustments should always be performed when replacing the following *components.</p> <ol style="list-style-type: none"> 1) Supply *Voltage AC to with *variable auto-transformer. 2) Input an entirely *signal. 3) Set the PICTURE control and the BRIGHTNESS control to adjustment. 4) Confirm the voltage of *TP is less than *Voltage DC. 5) If step 4) is not satisfied, replace the *components repeat above steps. 	<p>* Variable auto-transformer * Monoscope pattern</p>	<p>*IC643, R661</p> <p>*G Board CN641 Pin ① - ground</p>	<p>*VIDEO MODE : STANDARD PICTURE BRIGHTNESSinitial reset</p> <p>*R661</p>	<p>*130 ^{+2.0}₋₀ V AC</p> <p>* Less than 136.5 VDC</p>

SECTION 5
DIAGRAMS

5-1. BLOCK DIAGRAMS (1)

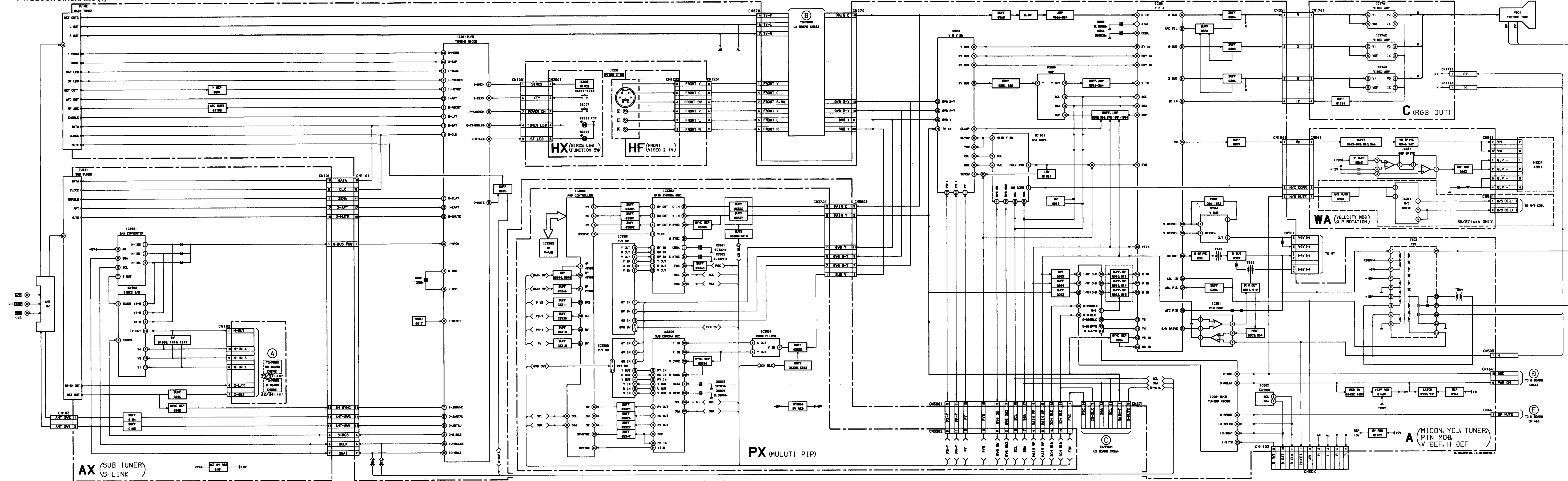

A

MICON, Y/C/J, TUNER,
HV DEF, PIN-MOD

- A BOARD - (KV-32XBR48/34XBR48C)

A BOARD

DIODE	IC561	F-3	
D001	B-5	IC1001	G-5
D002	B-5	TRANSISTOR *	
D003	D-8	Q001	E-7
D004	D-6	Q002	C-6
D011	D-8	Q003	B-2
D012	A-6	Q004	A-2
D013	D-6	Q005	D-7
D014	C-5	Q010	C-5
D015	C-6	Q011	C-5
D353	F-5	Q012	C-5
D356	C-5	Q013	C-5
D360	F-5	Q014	C-5
D362	F-5	Q015	C-5
D363	F-5	Q016	B-5
D368	F-6	Q017	D-7
D501	C-2	Q304	F-6
D502	G-2	Q305	F-6
D503	G-2	Q306	F-6
D504	F-1	Q351	H-6
D505	E-2	Q354	F-5
D506	E-2	Q356	D-6
D507	C-2	Q357	D-4
D515	D-3	Q358	F-5
D516	C-2	Q359	J-5
D518	C-2	Q360	J-5
D519	H-4	Q361	I-5
D520	C-3	Q362	J-5
D521	B-3	Q363	J-5
D522	B-3	Q364	J-4
D530	H-4	Q365	I-6
D531	I-4	Q366	H-7
D534	G-3	Q367	H-7
D536	C-5	Q368	G-6
D561	F-3	Q369	H-5
D562	E-4	Q370	J-5
D1001	E-6	Q501	C-1
D1002	F-6	Q502	G-1
D1003	H-5	Q503	C-4
D1004	H-5	Q504	C-3
D1102	H-7	Q511	C-3
D1103	I-7	Q512	D-4
D1301	J-5	Q530	B-2
D1302	J-5	Q531	B-2
D1304	J-5	Q561	E-4
D1305	J-5	Q562	E-4
D1306	J-5	Q563	B-1
D1641	A-7	Q1001	E-6
D1642	A-7	Q1102	I-7
D1691	B-4	Q1103	H-8
IC		Q1351	H-6
IC001	C-7	Q1352	J-5
IC002	B-6	Q1353	J-5
IC351	E-5	Q1354	I-5
IC352	H-5	Q1691	B-4
IC353	I-5	Q1692	B-3
IC501	C-3	Q1693	B-3

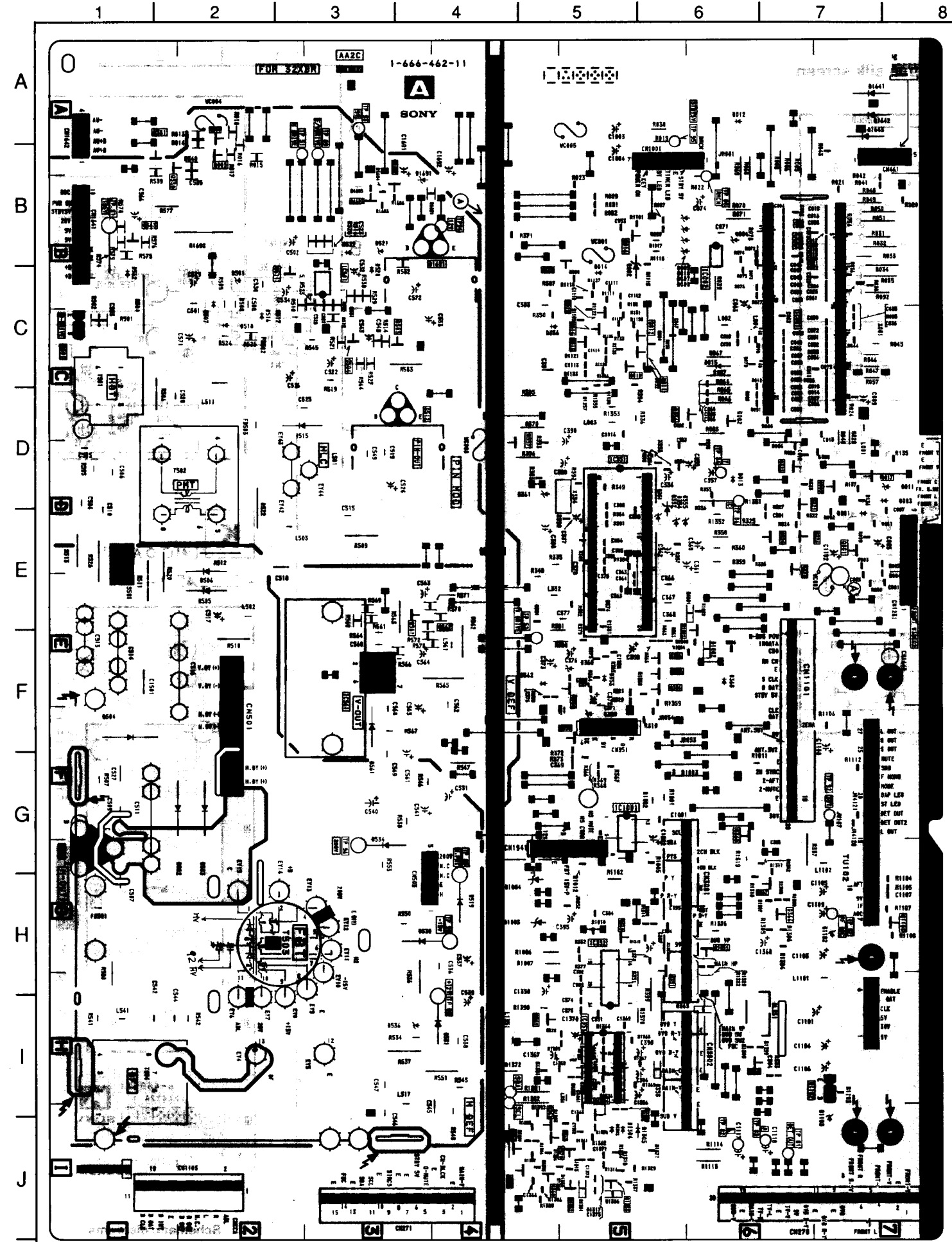

NOTE:
The circuit indicated as left contains high voltage of over 600 Vp-p. Care must be paid to prevent an electric shock in inspection or repairing.

- A BOARD - (KV-35XBR48/35XBR88/37XBR48M)

A BOARD

DIODE	IC561	F-3	
D001	B-5	IC1001	G-5
D002	B-5	TRANSISTOR *	
D003	D-8	Q001	E-7
D004	D-6	Q002	C-6
D011	D-8	Q003	B-2
D012	A-6	Q004	A-2
D013	D-6	Q005	D-7
D014	C-5	Q010	C-5
D015	C-6	Q011	C-5
D353	F-5	Q012	C-5
D356	C-5	Q013	C-5
D360	F-5	Q014	C-5
D362	F-5	Q015	C-5
D363	F-5	Q016	B-5
D368	F-6	Q017	D-7
D501	C-2	Q304	F-6
D502	G-2	Q305	F-6
D503	G-2	Q306	F-6
D504	F-1	Q351	H-6
D505	E-2	Q354	F-5
D506	E-2	Q356	D-6
D507	C-2	Q357	D-4
D515	D-3	Q358	F-5
D516	C-2	Q359	J-5
D518	C-2	Q360	J-5
D519	H-4	Q361	I-5
D520	C-3	Q362	J-5
D521	B-3	Q363	J-5
D522	B-3	Q364	J-4
D530	H-4	Q365	I-6
D531	I-4	Q366	H-7
D534	G-3	Q367	H-7
D536	C-5	Q368	G-6
D561	F-3	Q369	H-5
D562	E-4	Q370	J-5
D1001	E-6	Q501	C-1
D1002	F-6	Q502	G-1
D1003	H-5	Q503	C-4
D1004	H-5	Q504	C-3
D1102	H-7	Q511	C-3
D1103	I-7	Q512	D-4
D1301	J-5	Q530	B-2
D1302	J-5	Q531	B-2
D1304	J-5	Q561	E-4
D1305	J-5	Q562	E-4
D1306	J-5	Q563	B-1
D1641	A-7	Q1001	E-6
D1642	A-7	Q1102	I-7
D1691	B-4	Q1103	H-8
IC		Q1351	H-6
IC001	C-7	Q1352	J-5
IC002	B-6	Q1353	J-5
IC351	E-5	Q1354	I-5
IC352	H-5	Q1691	B-4
IC353	I-5	Q1692	B-3
IC501	C-3	Q1693	B-3

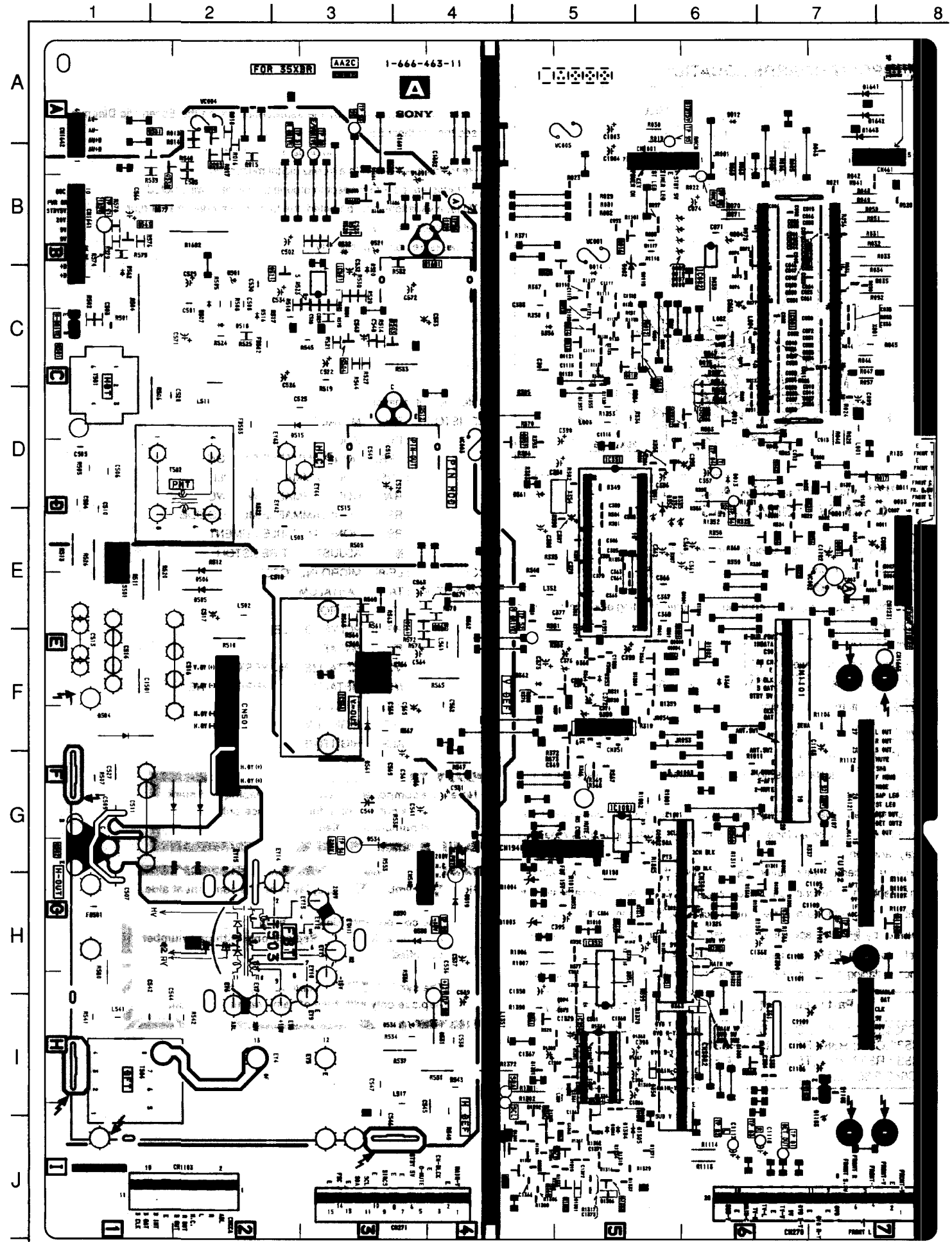

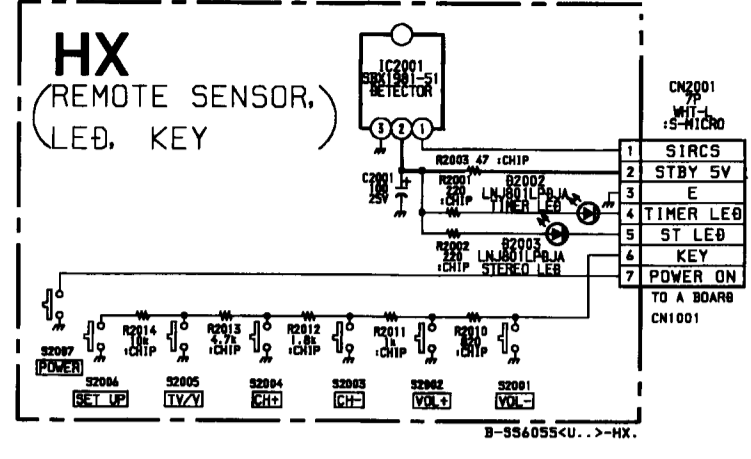
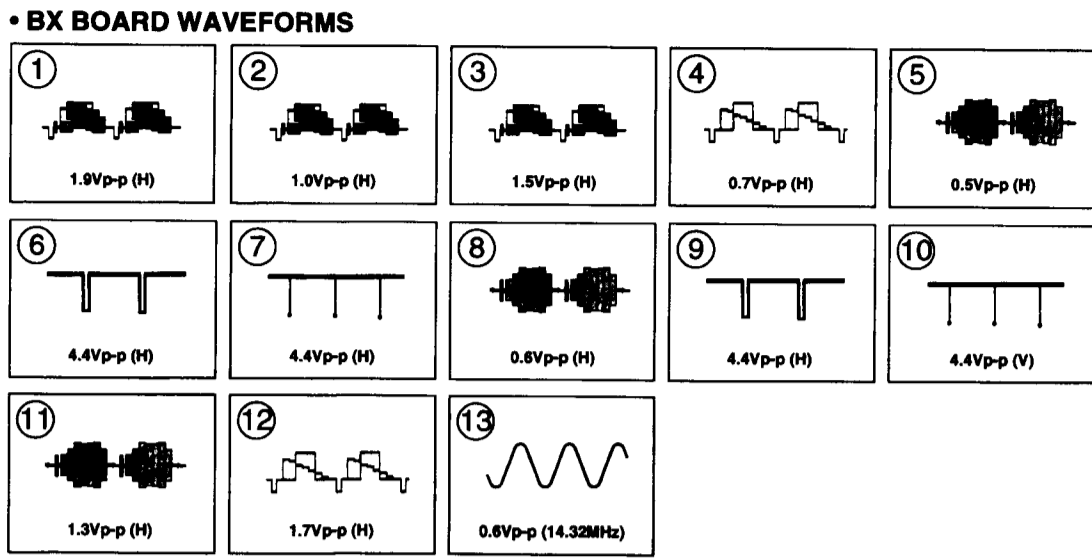
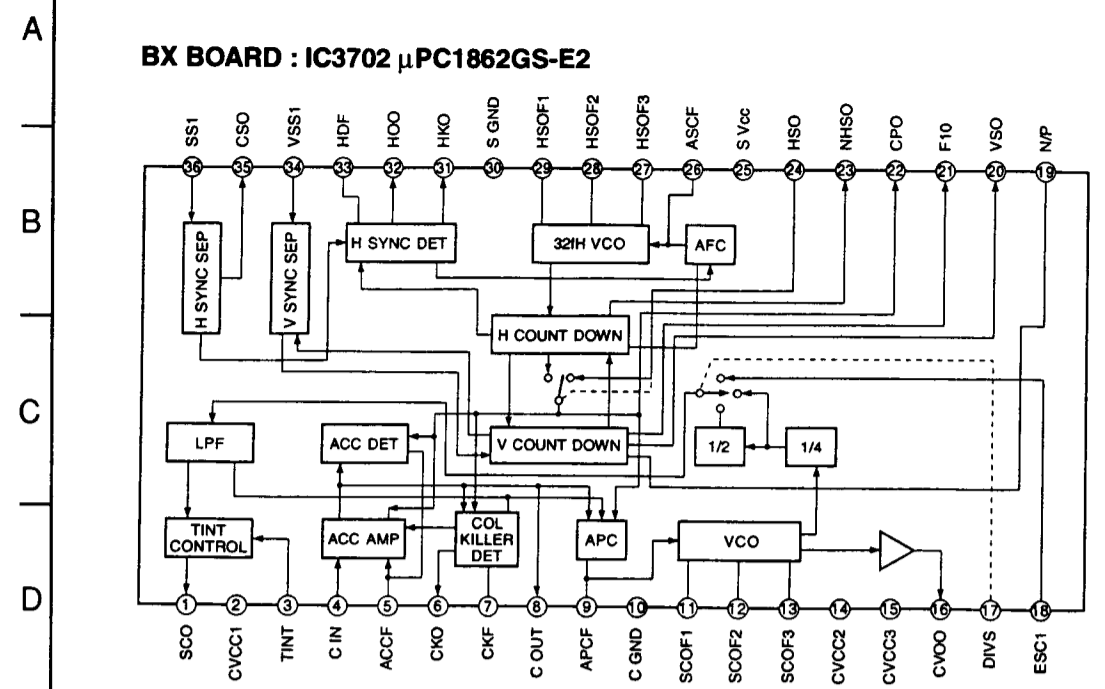

HX BOARD IC VOLTAGE LIST

IC2001	1	5.2
	2	5.2
	3	GND

All Voltages are in V
Pin numbers which are not described are not used.

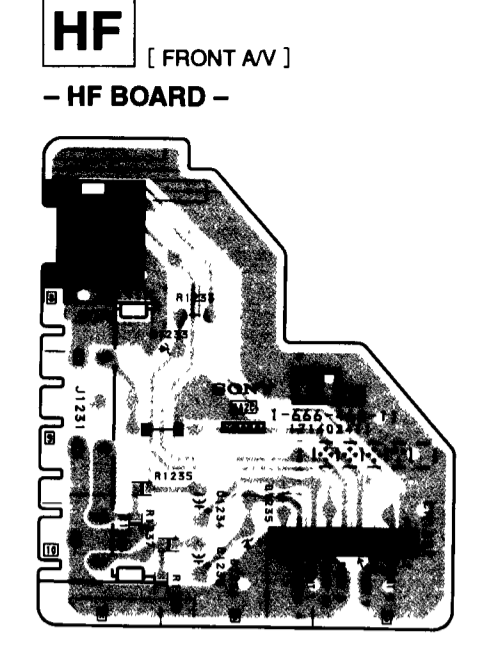
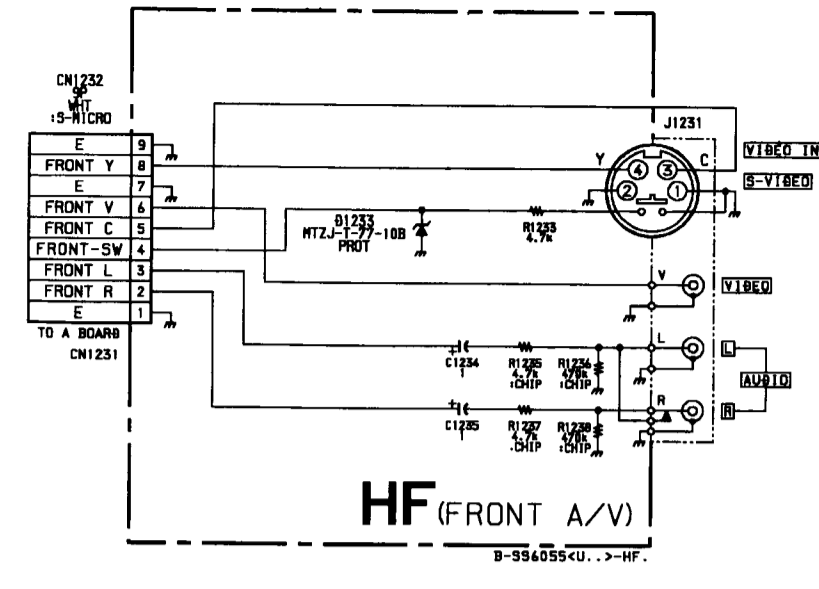

HX [REMOTE SENSOR, LED, KEY]
- HX BOARD -

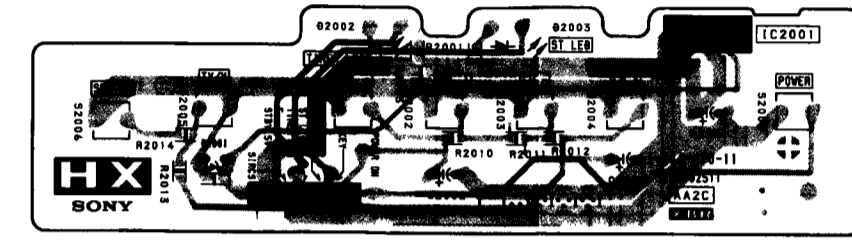
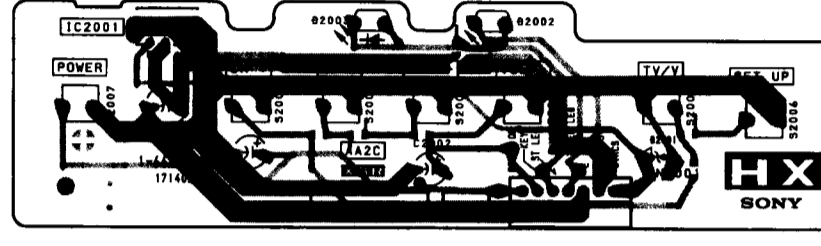

NOTE:
 • Pattern from the side which enables seeing
 • Pattern of the rear side.

BX [DIGITAL COMB FILTER]
- BX BOARD -

BX BOARD

DIODE

- D3704 A-3
- D3705 E-4
- D3706 A-4
- D3707 E-4
- D3708 A-4

IC

- IC3702 B-2,F-2
- IC3703 C-4,E-4
- IC3706 A-2
- IC3707 B-3
- IC3708 A-4
- IC3709 B-4

TRANSISTOR

- Q3701 C-2
- Q3702 E-3
- Q3703 C-1
- Q3707 B-2
- Q3708 E-4
- Q3709 B-2
- Q3719 A-2
- Q3724 E-2
- Q3726 E-2
- Q3729 E-3
- Q3729 E-2
- Q3731 E-3
- Q3732 E-3
- Q3733 G-1
- Q3734 G-1

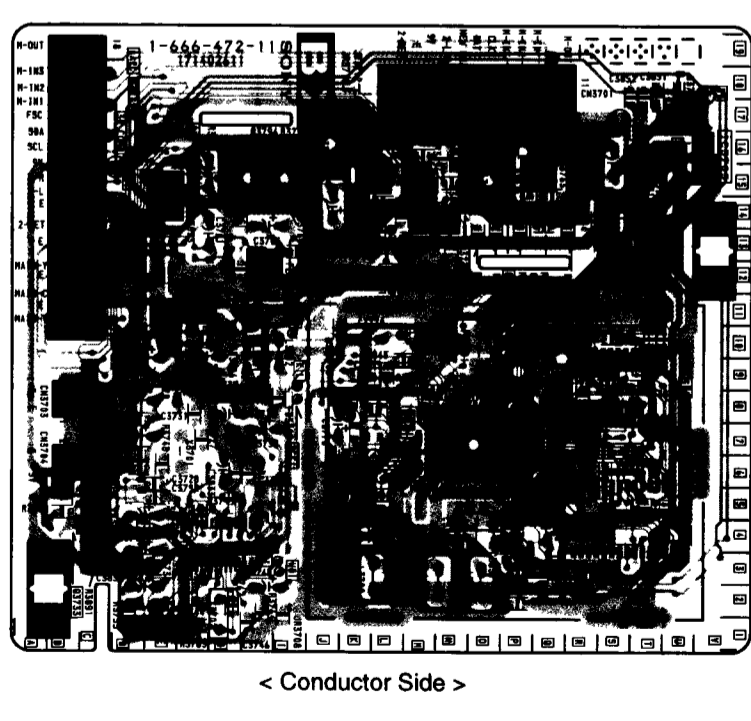
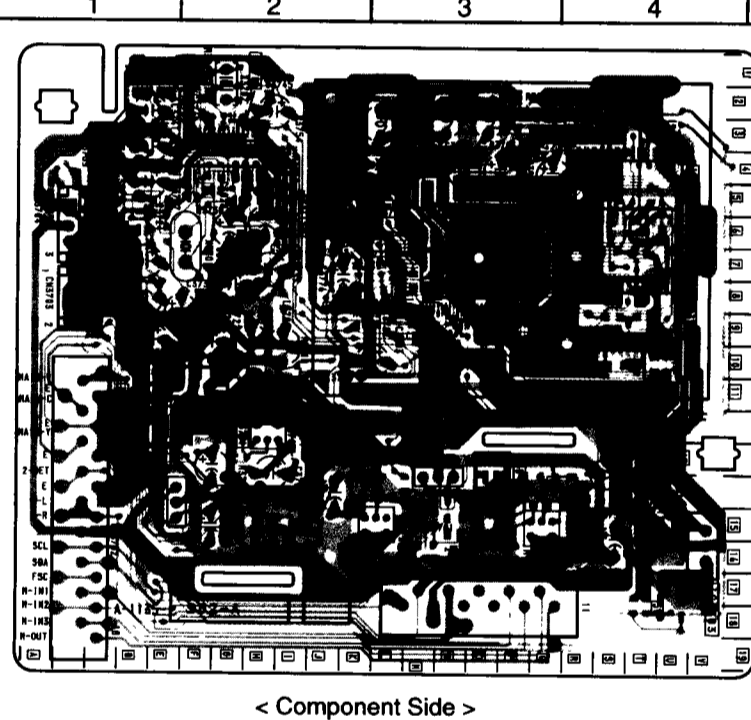

NOTE:
 • Pattern from the side which enables seeing
 • Pattern of the rear side

BX (DIGITAL COMB FILTER)

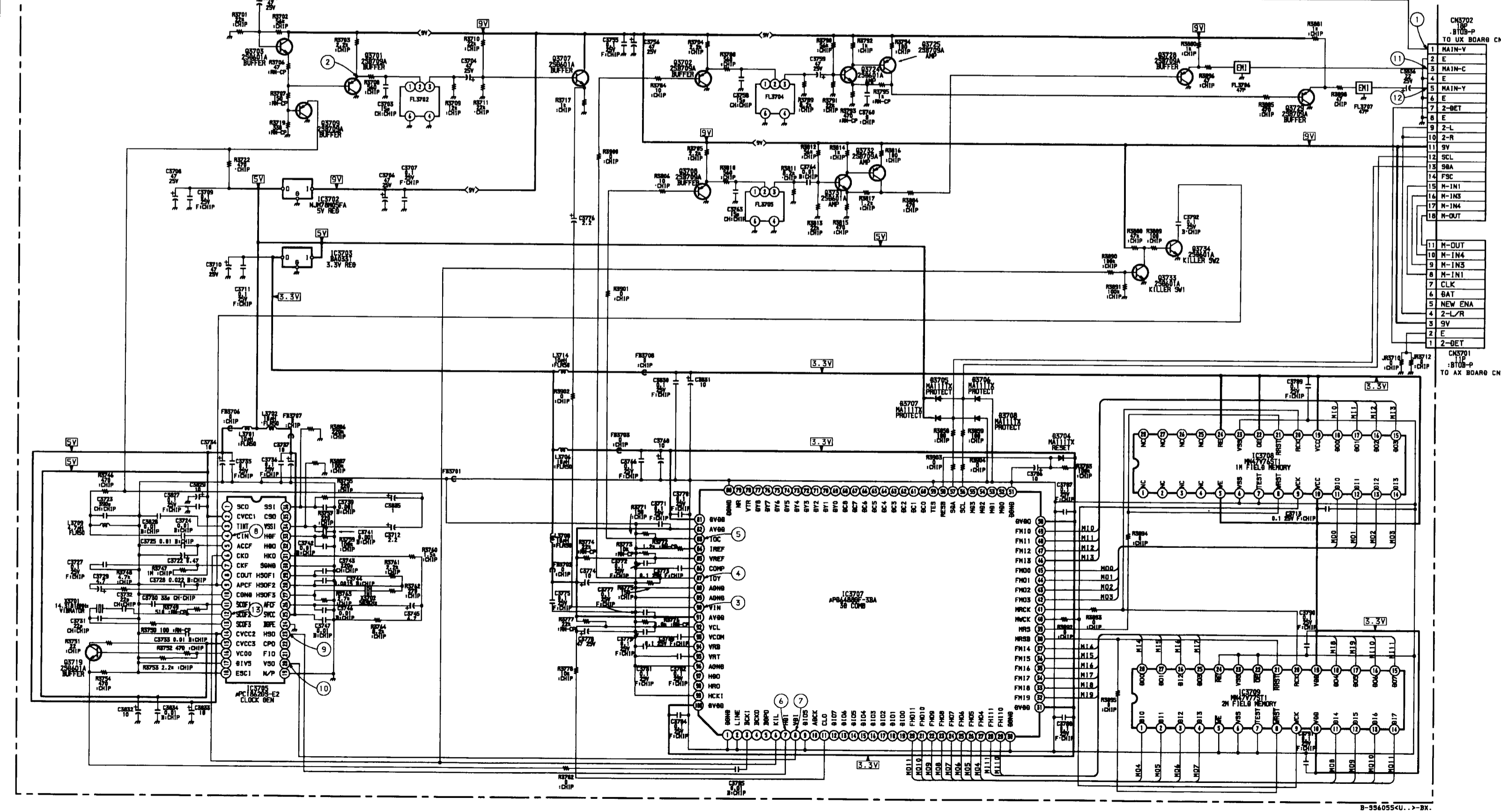

BX BOARD IC VOLTAGE LIST

IC3702	1	8.7
	2	5.3
	3	GND
	4	5.3
	5	5.3
	6	GND
	7	4.4
	8	0.9
	9	5.3
	10	5.3
	11	5.3
	12	0
	13	0
	14	5.3
	15	4.4
	16	2.8
	17	4.4
	18	2.8
	19	2.8
	20	5.3
	21	1.1
	22	1.1
	23	1.1
	24	3.5
	25	2.4
	26	2.6
	27	2.9
	28	0
	29	0
	30	3.1
	31	3.1
	32	3.3
	33	5.3
	34	2.2
	35	0
	36	0
	37	GND
	38	1.9
	39	1.3
	40	1.6
	41	1.6
	42	1.6
	43	1.6
	44	1.6
	45	1.6
	46	1.6
	47	1.6
	48	1.7

BX BOARD TRANSISTOR VOLTAGE LIST

Q3701	1	GND	2.1
Q3702	2	8.7	1.7
Q3703	2	8.7	1.7
Q3707	4	8.7	3.6
Q3708	2	3	3.6
Q3709	5	GND	1.2
Q3724	2	5	1.7
Q3726	7	4	8.4
Q3728	5	1	5.8
Q3729	4	6	5.3
Q3731	2	5	1.8
Q3732	7	5	1.8
Q3733	0	7	0
Q3734	0	0	GND

All Voltages are in V

BX BOARD IC VOLTAGE LIST

IC3705	1	8.7
	2	5.3
	3	GND
	4	5.3
	5	5.3
	6	GND
	7	4.4
	8	0.9
	9	5.3
	10	5.3
	11	5.3
	12	0
	13	0
	14	5.3
	15	4.4
	16	2.8
	17	4.4
	18	2.8
	19	2.8
	20	5.3
	21	1.1
	22	1.1
	23	1.1
	24	3.5
	25	2.4
	26	2.6
	27	2.9
	28	0
	29	0
	30	3.1
	31	3.1
	32	3.3
	33	5.3
	34	2.2
	35	0
	36	0
	37	GND
	38	1.9
	39	1.3
	40	1.6
	41	1.6
	42	1.6
	43	1.6
	44	1.6
	45	1.6
	46	1.6
	47	1.6
	48	1.7

BX BOARD TRANSISTOR VOLTAGE LIST

Q3701	1	GND	2.1
Q3702	2	8.7	1.7
Q3703	2	8.7	1.7
Q3707	4	8.7	3.6
Q3708	2	3	3.6
Q3709	5	GND	1.2
Q3724	2	5	1.7
Q3726	7	4	8.4
Q3728	5	1	5.8
Q3729	4	6	5.3
Q3731	2	5	1.8
Q3732	7	5	1.8
Q3733	0	7	0
Q3734	0	0	GND

All Voltages are in V

PX [MULTI PIP]
- PX BOARD -

PX BOARD

DIODE

- D3302 C-2
- D3303 C-2
- D3313 B-2
- D3314 B-2

IC

- IC3301 C-3
- IC3302 C-2
- IC3303 B-4
- IC3304 A-4
- IC3306 A-3,G-3
- IC3307 B-1
- IC3308 A-3
- IC3309 B-1

TRANSISTOR

- Q3301 D-3
- Q3302 D-3
- Q3303 C-3
- Q3305 C-2
- Q3306 C-2
- Q3310 D-1
- Q3308 C-1
- Q3309 E-1
- Q3311 C-3
- Q3318 B-3
- Q3319 B-2
- Q3320 B-3
- Q3325 F-3
- Q3326 F-3
- Q3327 F-3
- Q3330 A-2
- Q3333 G-1
- Q3339 C-1
- Q3342 C-1
- Q3343 B-2
- Q3344 E-3
- Q3345 E-3
- Q3346 E-2
- Q3347 F-3

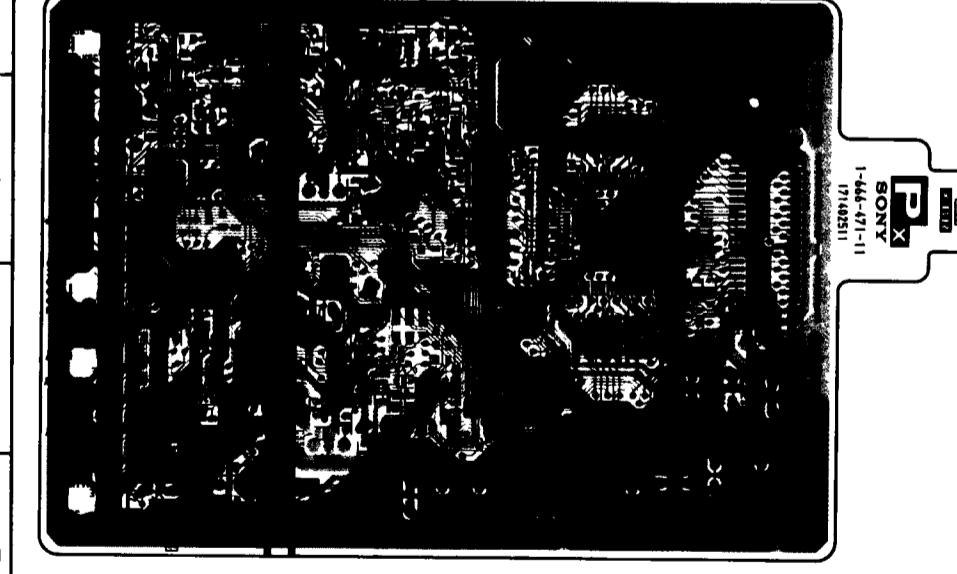
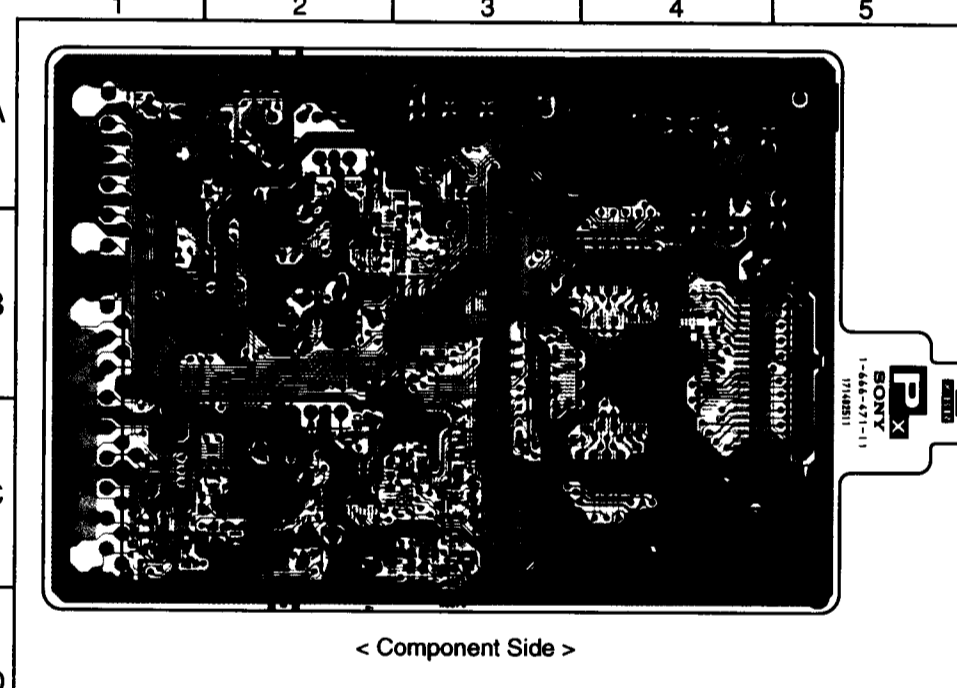

NOTE:
 • Pattern from the side which enables seeing
 • Pattern of the rear side.

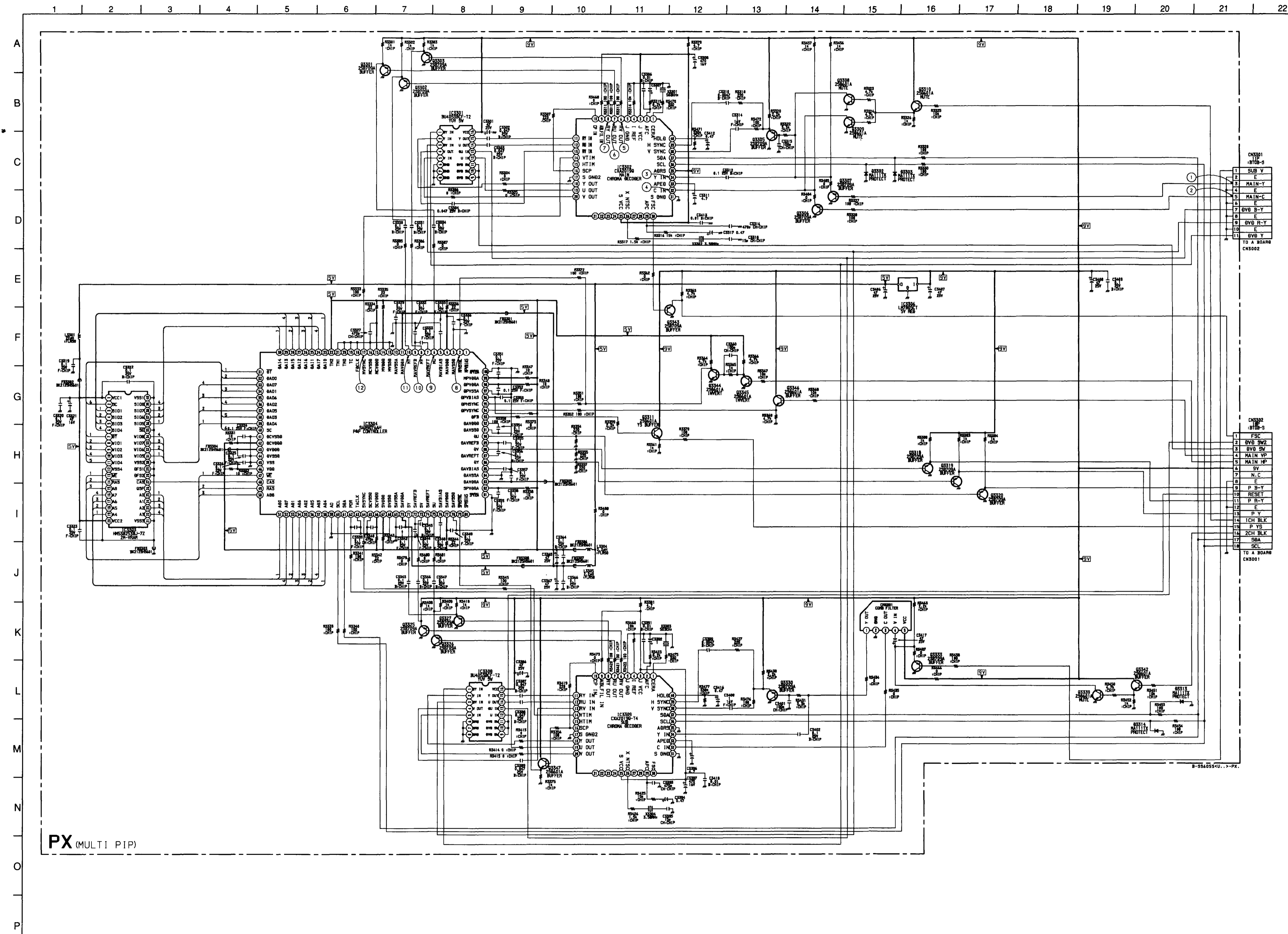

PX BOARD IC VOLTAGE LIST

IC	Pin	Voltage	IC	Pin	Voltage	IC	Pin	Voltage		
IC3301	1	0.2	13	3.3	36	1.0	98	5.3		
IC3301	2	0	14	2.0	37	1.0	99	5.3		
IC3301	3	3.4	15	1.4	38	1.0	100	GND		
IC3301	4	2.9	16	1.3	39	1.0	IC3306	1	0.0	
IC3301	5	2.9	17	1.4	40	0	O	5.3		
IC3301	6	GND	18	1.3	41	GND	G	GND		
IC3301	7	GND	19	1.3	42	5.1	IC3306	1	0	
IC3301	8	GND	20	2.9	43	5.3	IC3306	2	2.9	
IC3301	9	0	21	GND	44	GND	3	3.4		
IC3301	10	0	22	1.3	45	GND	4	2.9		
IC3301	11	0	23	1.3	46	5.3	IC3306	5	2.9	
IC3301	12	0	24	1.2	47	5.3	IC3306	6	GND	
IC3301	13	3.5	25	1.2	48	3.0	IC3306	7	GND	
IC3301	14	2.9	26	3.0	49	2.0	IC3306	8	GND	
IC3301	15	3.3	28	GND	50	1.4	IC3306	9	0.5	
IC3301	16	3.0	29	2.9	51	1.3	IC3306	10	0.5	
IC3302	1	2.3	30	GND	52	1.3	IC3306	11	0.5	
IC3302	2	4.1	31	1.0	53	1.3	IC3306	12	2.9	
IC3302	3	8.6	32	1.0	54	1.3	IC3306	13	3.5	
IC3302	4	1.9	33	0.8	55	1.3	IC3306	14	2.9	
IC3302	5	GND	34	0.9	56	1.3	IC3306	15	2.9	
IC3302	6	2.9	35	GND	57	1.3	IC3306	16	0.0	
IC3302	7	2.9	36	0.3	58	1.3	IC3309	1	2.3	
IC3302	8	3.3	37	0.2	59	GND	IC3309	2	4.1	
IC3302	9	8.6	38	0.3	60	4.7	IC3309	3	8.6	
IC3302	10	0.8	39	0.2	61	4.7	IC3309	4	1.8	
IC3302	11	4.5	40	GND	62	5.3	IC3309	5	GND	
IC3302	12	4.5	IC3304	1	1.7	63	GND	IC3309	6	2.9
IC3302	13	4.5	IC3304	2	1.0	64	1.0	IC3309	7	2.9
IC3302	14	0.3	IC3304	3	GND	65	GND	IC3309	8	2.9
IC3302	15	0.8	IC3304	4	5.1	66	5.0	IC3309	9	8.7
IC3302	16	0.8	IC3304	5	2.5	67	4.9	IC3309	10	0.8
IC3302	17	1.4	IC3304	6	1.4	68	GND	IC3309	11	2.9
IC3302	18	3.3	IC3304	7	2.2	69	GND	IC3309	12	4.3
IC3302	19	2.9	IC3304	8	1.4	70	5.3	IC3309	13	4.3
IC3302	20	2.9	IC3304	9	0.5	71	0.5	IC3309	14	0.3
IC3302	21	0.8	IC3304	10	0.9	72	0.5	IC3309	15	0.8
IC3302	22	2.4	IC3304	11	5.3	73	1.4	IC3309	16	0.8
IC3302	23	2.4	IC3304	12	GND	74	2.3	IC3309	17	GND
IC3302	24	5.2	IC3304	13	GND	75	1.4	IC3309	18	2.8
IC3302	25	0.8	IC3304	14	4.9	76	2.5	IC3309	19	2.9
IC3302	26	4.4	IC3304	15	5.0	77	5.1	IC3309	20	2.9
IC3302	27	4.4	IC3304	16	GND	78	GND	IC3309	21	8.7
IC3302	28	4.4	IC3304	17	0.3	79	0.5	IC3309	22	2.3
IC3302	29	8.6	IC3304	18	GND	80	1.7	IC3309	23	5.2
IC3302	30	4.7	IC3304	19	GND	81	GND	IC3309	24	GND
IC3302	31	4.7	IC3304	20	GND	82	5.3	IC3309	25	4.7
IC3302	32	3.8	IC3304	21	GND	83	5.3	IC3309	26	3.8
IC3302	33	3.2	IC3304	22	5.3	84	GND	IC3309	27	3.9
IC3302	34	2.7	IC3304	23	0.4	85	1.1	IC3309	28	3.1
IC3302	35	0.3	IC3304	24	0.3	86	0.5	IC3309	29	4.7
IC3302	36	0.3	IC3304	25	0.3	87	2.4	IC3309	30	4.7
IC3302	37	5.3	IC3304	26	0.3	88	1.3	IC3309	31	3.9
IC3302	38	0.9	IC3304	27	0.3	89	0.5	IC3309	32	3.1
IC3302	39	0.5	IC3304	28	0.9	90	1.3	IC3309	33	4.7
IC3302	40	1.0	IC3304	29	0.3	91	GND	IC3309	34	0.8
IC3302	41	1.0	IC3304	30	0.3	92	5.3	IC3309	35	1.7
IC3302	42	1.0	IC3304	31	5.3	93	3.1	IC3309	36	4.7
IC3302	43	1.0	IC3304	32	0.9	94	0.5	IC3309	37	4.7
IC3302	44	1.0	IC3304	33	0.9	95	1.0	IC3309	38	5.0
IC3302	45	1.0	IC3304	34	0.5	96	1.7	IC3309	39	1.7
IC3302	46	1.0	IC3304	35	0.8	97	GND	IC3309	40	0.8

Pin numbers which are not described are not used.

PX BOARD TRANSISTOR VOLTAGE LIST

Transistor	Pin	Voltage	Transistor	Pin	Voltage
Q3301	2.9	GND	3.6	3.6	3.6
Q3302	3.3	GND	3.9	3.9	3.9
Q3303	2.9	GND	3.6	3.6	3.6
Q3305	5.8	GND	8.4	8.4	8.4
Q3306	5.1	GND	5.8	5.8	5.8
Q3307	5.1	GND	5.8	5.8	5.8
Q3308	0	5.8	GND	5.8	5.8
Q3309	0	5.7	GND	5.7	5.7
Q3310	0	9.0	0	9.0	9.0
Q3311	0	9.0	0	9.0	9.0
Q3318	1.3	GND	2.0	2.0	2.0
Q3319	0.5	GND	1.2	1.2	1.2
Q3320	1.3	GND	2.0	2.0	2.0
Q3325	2.9	GND	3.6	3.6	3.6
Q3326	2.8	GND	3.5	3.5	3.5
Q3327	2.9	GND	3.5	3.5	3.5
Q3330	4.8	GND	5.4	5.4	5.4
Q3333	5.1	GND	5.7	5.7	5.7
Q3339	0	5.7	GND	5.7	5.7
Q3342	0	9.0	0	9.0	9.0
Q3343	1.5	GND	2.2	2.2	2.2
Q3344	0.7	1.0	GND	1.0	1.0
Q3345	0.4	1.3	GND	1.3	1.3
Q3346	0.7	9.0	0.5	9.0	9.0
Q3347	0.8	9.0	0.8	9.0	9.0

All Voltage are in V

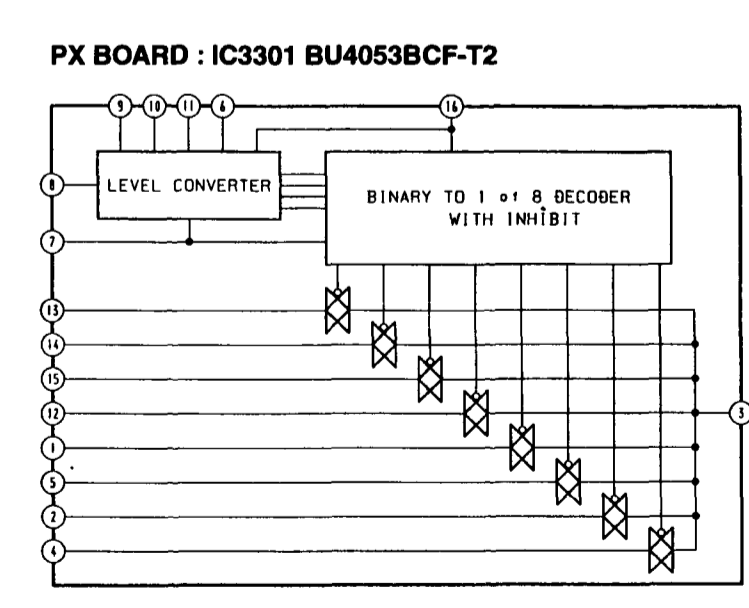
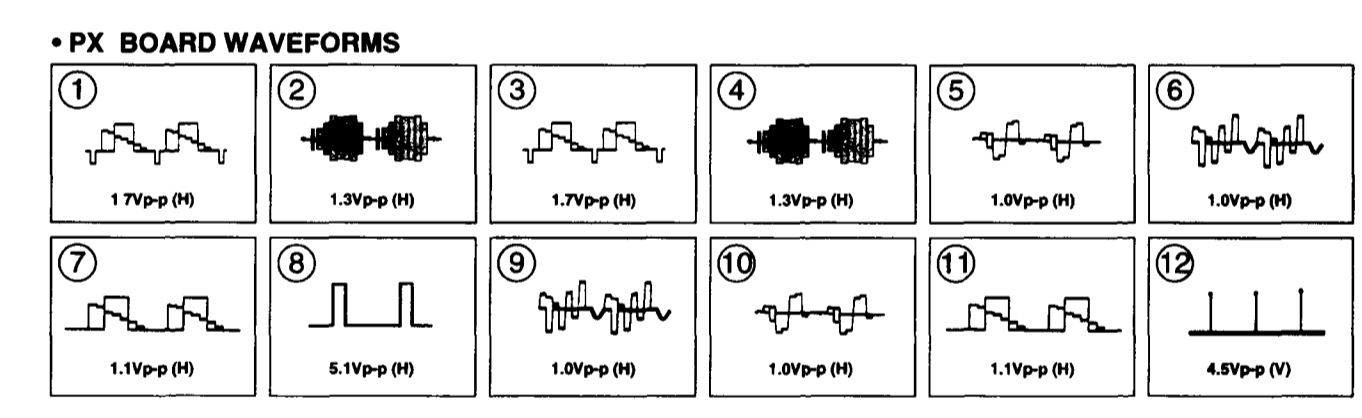

UX BOARD : IC261 CXA1845Q

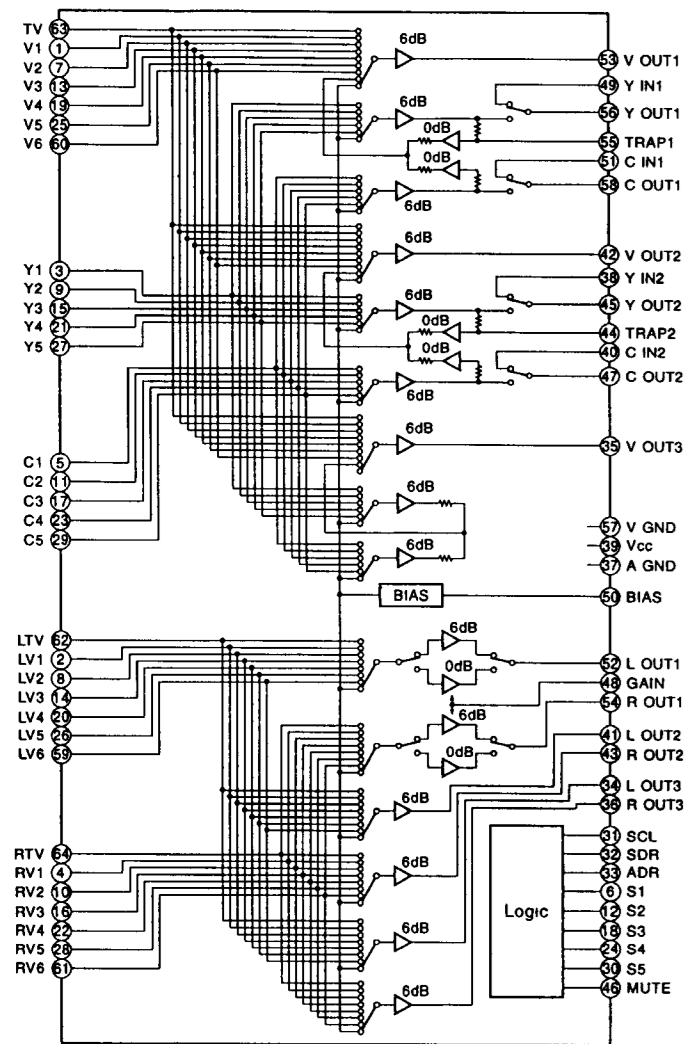

UX BOARD WAVEFORMS

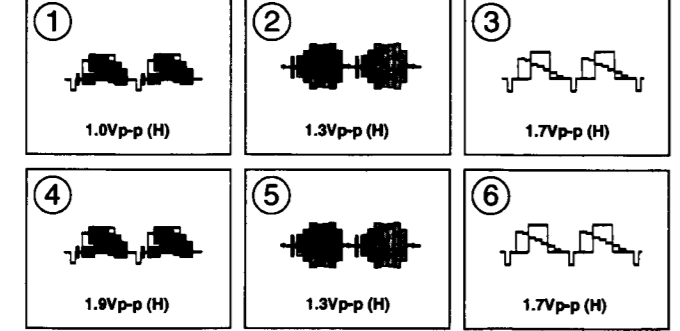

UX BOARD IC VOLTAGE LIST

IC	Pin	V	IC	Pin	V
IC151	1	4.4	IC156	39	8.9
	2	4.5		42	4.4
	3	4.5		43	4.5
	4	8.9		44	GND
	5	4.4		45	4.5
	6	4.5		46	4.5
	7	4.4		47	4.5
	8	4.4		48	GND
	9	4.5		49	4.5
	10	4.4		50	4.5
	11	GND		51	4.5
IC152	1	4.5	IC157	52	4.6
	2	4.5		53	4.4
	3	4.5		54	4.6
	4	8.9		55	4.4
	5	4.5		56	4.5
	6	4.5		57	GND
	7	4.5		58	4.5
	8	4.4		59	4.5
	9	4.5		60	4.5
	10	4.5		61	4.5
	11	GND		62	4.5
IC153	1	4.4	IC1051	1	0.2
	2	4.4		2	0.2
	3	4.4		3	4.4
	4	8.9		4	4.4
	5	4.5		5	4.4
	6	4.5		6	4.4
	7	4.5		7	4.4
	8	GND		8	GND
	9	4.5		9	0.2
	10	4.5		10	GND
	11	GND		11	GND
IC261	1	4.5	IC1401	1	4.4
	2	4.5		2	4.4
	3	4.5		3	4.4
	4	4.5		4	4.4
	5	4.5		5	4.4
	6	4.5		6	4.4
	7	4.5		7	4.4
	8	4.5		8	4.4
	9	4.5		9	4.4
	10	4.5		10	4.4
	11	GND		11	GND
IC154	1	4.4	IC1402	1	4.3
	2	4.4		2	4.4
	3	4.4		3	4.4
	4	4.4		4	4.4
	5	4.4		5	4.4
	6	4.4		6	4.4
	7	4.4		7	4.4
	8	4.4		8	4.4
	9	4.4		9	4.4
	10	4.4		10	4.4
	11	GND		11	GND
IC155	1	4.4	IC1402	12	4.4
	2	4.4		13	4.7
	3	4.4		14	4.7
	4	4.4		15	4.4
	5	4.4		16	4.4
	6	4.4		17	4.4
	7	4.4		18	0
	8	4.4		19	4.5
	9	4.4		20	4.5
	10	4.4		21	2.2
	11	GND		22	2.2

All Voltage are in V
Pin numbers which are not described are not used.

UX BOARD : IC1051 CXA1315M-T4

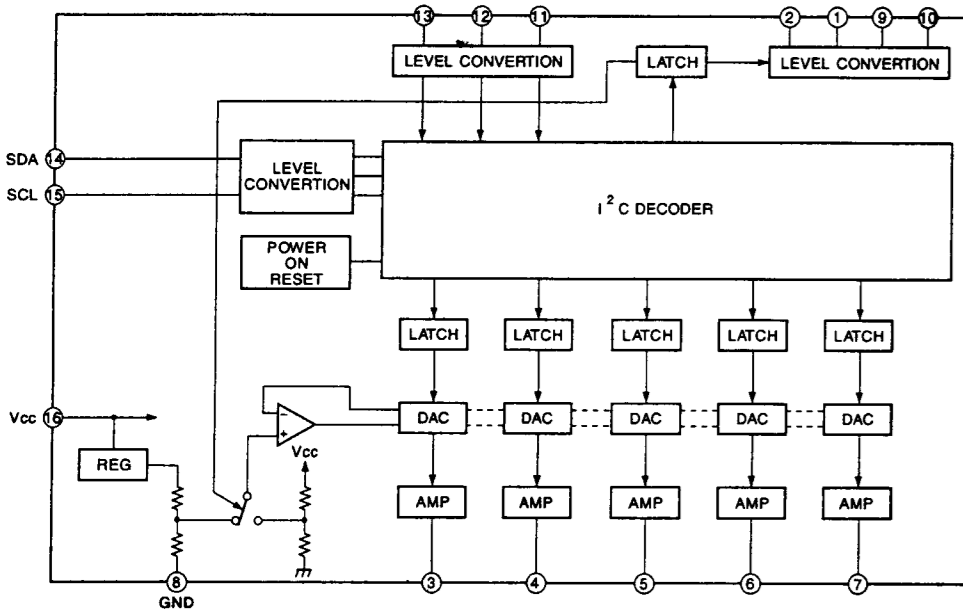

UX BOARD : IC1401 BH3856FS

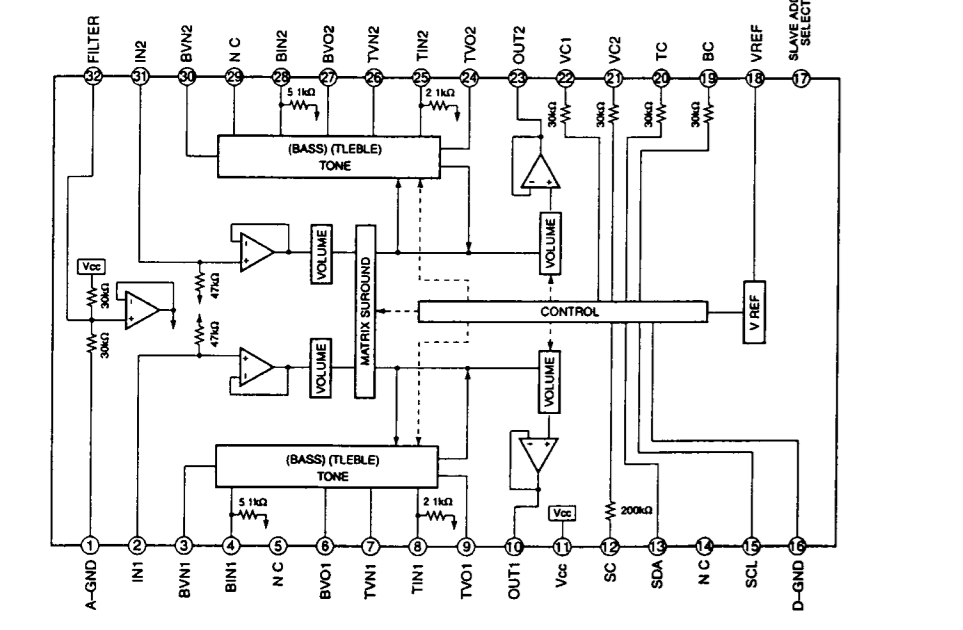

UX BOARD : IC154 MC14052BFEL

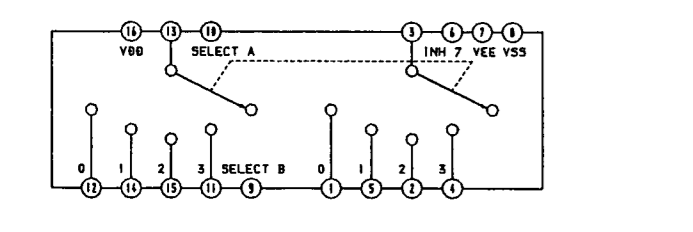

UX BOARD TRANSISTOR VOLTAGE LIST

Q	B	C	E
Q202	2.8	7.8	2.2
Q203	2.7	7.8	2.2
Q205	7.8	4.1	8.4
Q206	7.8	4.0	8.4
Q208	14.1	8.9	3.5
Q209	4.0	8.9	3.5
Q210	2.9	7.8	2.2
Q211	7.8	4.2	8.5
Q212	4.2	8.9	3.5
Q231	-0.8	5.1	GND
Q233	-1.2	0	GND
Q234	-1.2	0	GND
Q235	0	0	GND
Q236	0	0	GND
Q237	4.4	GND	5.1
Q238	4.5	GND	5.2
Q239	4.5	GND	5.1
Q240	-0.3	5.1	GND
Q241	-0.3	5.1	GND
Q242	-0.3	5.1	GND
Q243	4.4	GND	5.1
Q244	4.4	GND	5.1
Q245	4.4	GND	5.1
Q246	0	5.1	GND
Q253	4.4	GND	5.1
Q264	4.5	GND	5.1
Q265	4.8	8.9	4.2
Q266	4.4	GND	5.0
Q267	0.3	GND	1.0
Q268	2.2	GND	2.9
Q1051	8.8	-8.7	8.8

All Voltage are in V

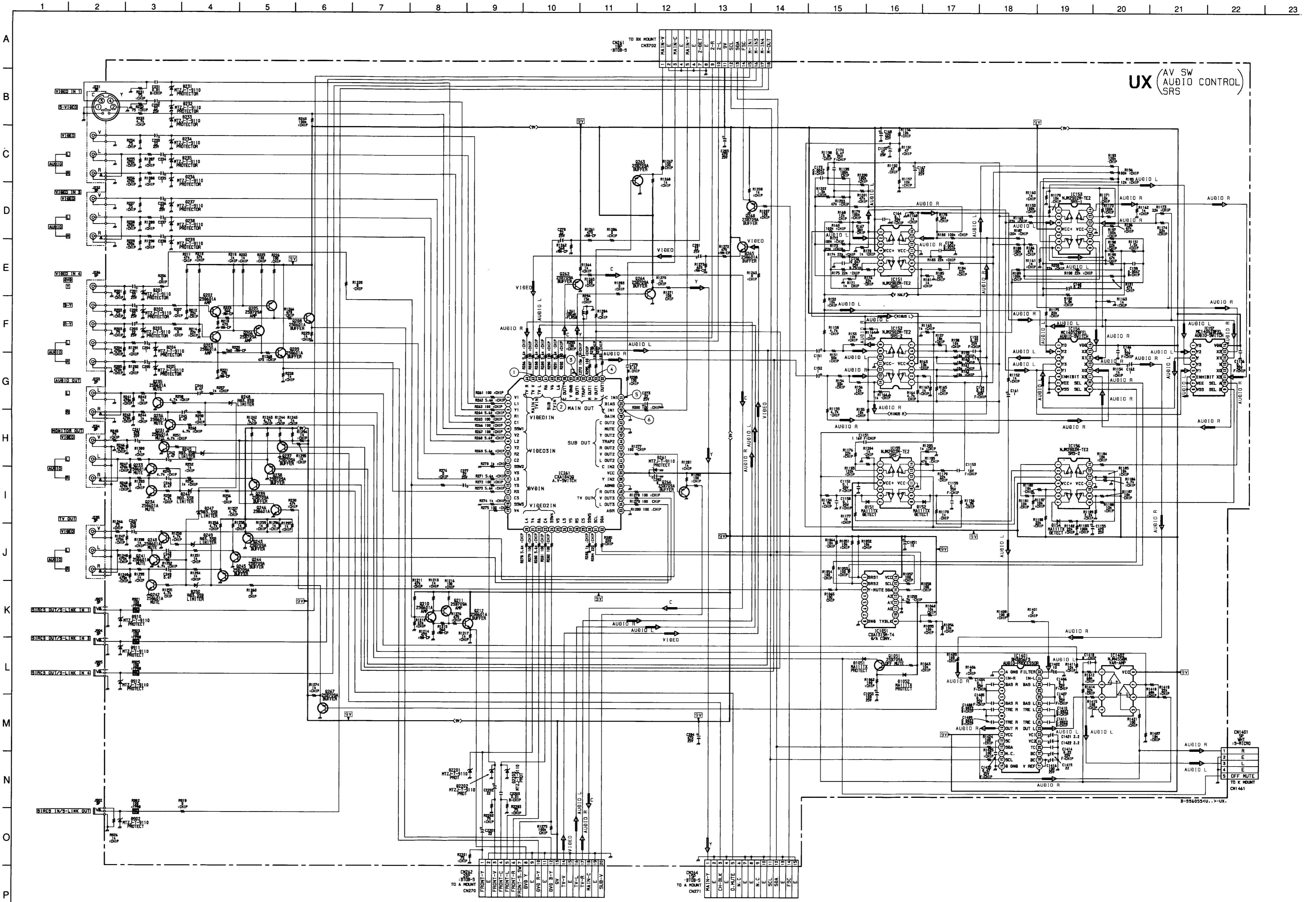

-UX BOARD -

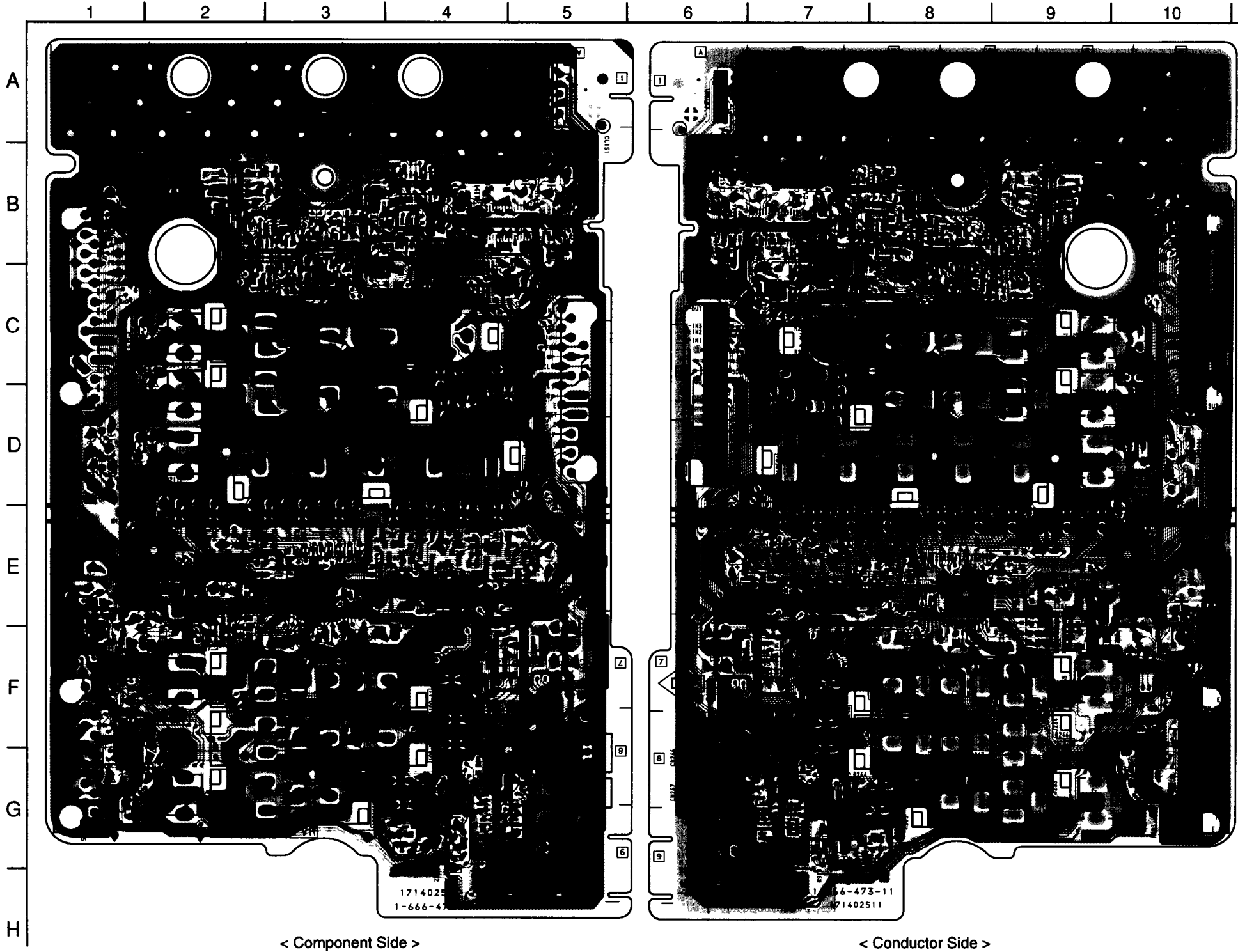

< Component Side >

< Conductor Side >

UX BOARD

DIODE		*	IC156	B-4
D151	B-7	③	IC157	C-4
D152	B-7	③	IC261	E-3
D154	B-3	③	IC1051	G-4
D201	E-7	-	IC1401	B-5
D202	E-7	-	IC1402	B-5
D203	E-7	-	TRANSISTOR *	
D204	E-2,E-9	-	Q202	E-7
D205	E-2,E-10	-	Q203	E-8
D231	C-7	-	Q205	E-7
D232	D-4,D-7	-	Q206	E-8
D233	D-4,D-7	-	Q208	E-7
D234	C-4,C-7	-	Q209	E-7
D235	E-3,E-8	-	Q210	E-1
D236	E-3,E-8	-	Q211	D-2
D237	D-4,D-7	-	Q212	D-1
D238	E-3,E-9	-	Q231	F-7
D239	E-2,E-9	-	Q233	F-8
D245	F-7	③	Q234	F-9
D246	F-9	③	Q235	G-8
D247	E-1	③	Q236	G-9
D248	G-9	③	Q237	F-5
D249	E-1	③	Q238	F-5
D250	F-10	③	Q239	F-5
D261	F-3,F-8	-	Q240	E-10
D902	G-2	-	Q241	E-10
D910	C-2,C-10	-	Q242	F-10
D911	D-2	-	Q243	F-9
D912	D-2,D-10	-	Q244	F-9
D1051	G-7	③	Q245	F-9
D1052	G-6	③	Q246	F-7
D2201	D-1,D-10	-	Q262	E-4
D2202	D-1,D-10	-	Q263	F-6
D2203	D-1,D-10	-	Q264	E-4
			Q265	E-2
I C			Q266	F-8
IC151	B-3		Q267	F-1
IC152	B-2		Q268	G-5
IC153	B-3		Q1051	G-6
IC154	C-4			
IC155	B-4			

NOTE:

- Pattern from the side which enables seeing
- Pattern of the rear side.

C BOARD IC VOLTAGE LIST

IC1761	1	3.6
	2	9.1
	3	6.6
	4	GND
	5	6.6
	6	217.0
	7	150.0
	8	152.0
	9	149.0
IC1762	1	3.6
	2	9.10
	3	3.6
	4	GND
	5	5.9
	6	217.0
	7	156.0
	8	158.0
	9	155.0
IC1763	1	3.6
	2	9.1
	3	3.5
	4	GND
	5	3.8
	6	217
	7	152
	8	154
	9	151

All Voltage are in V
Pin numbers which are not
not described are not used.

**C BOARD
TRANSISTOR VOLTAGE LIST**

Q761	B	C	E
	3.9	0.2	3.4

All Voltage are in V

C BOARD * MARK LIST

R1787	KX-35XBR48/35XBR88/37XBR48M	KV-32XBR48/34XBR48C
	2.7 2W RS	0.47 2W RS

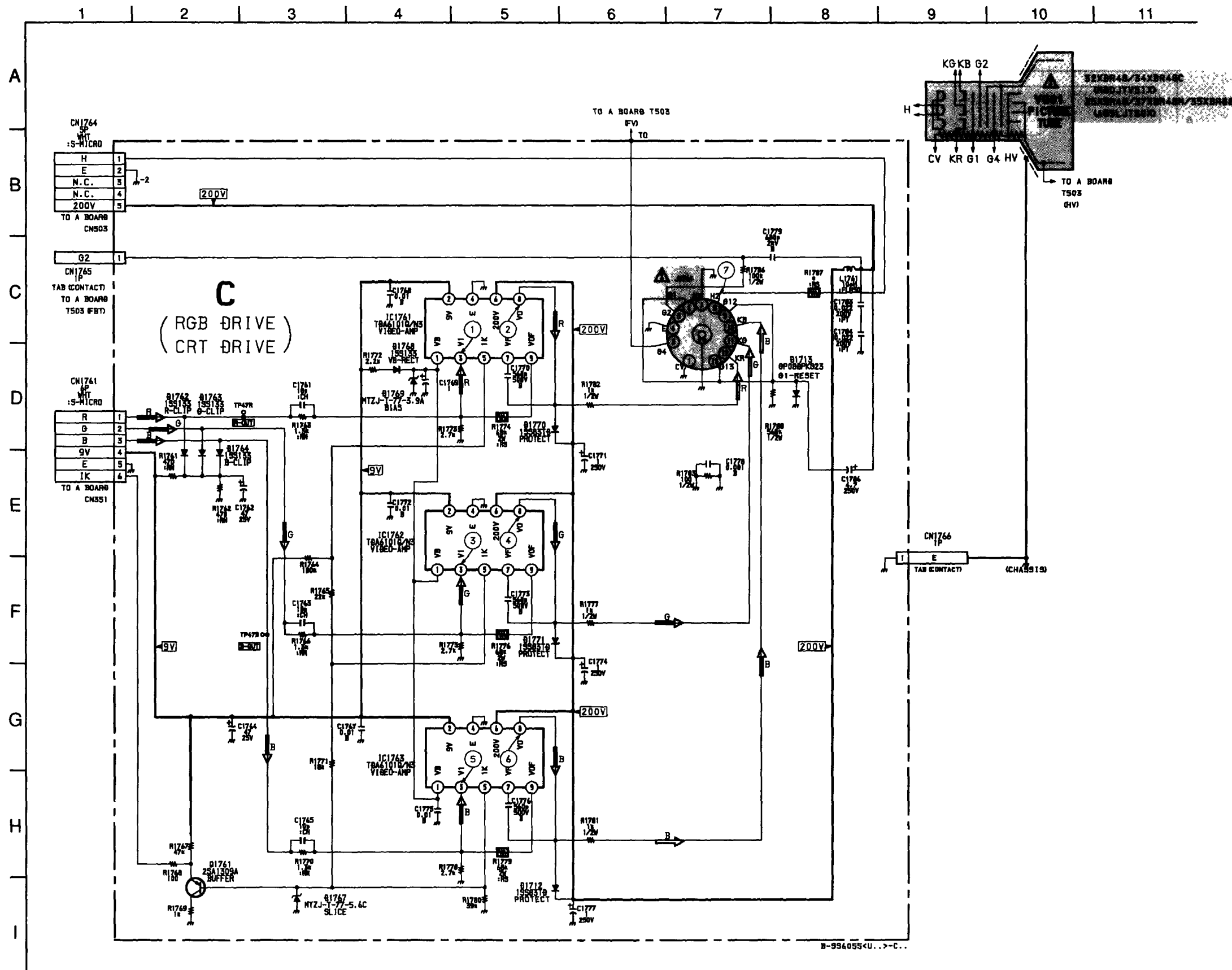

B-994055<U...>-C..

Schematic diagrams

C board =>

C [RGB DRIVE, CRT DRIVE]

- C BOARD -

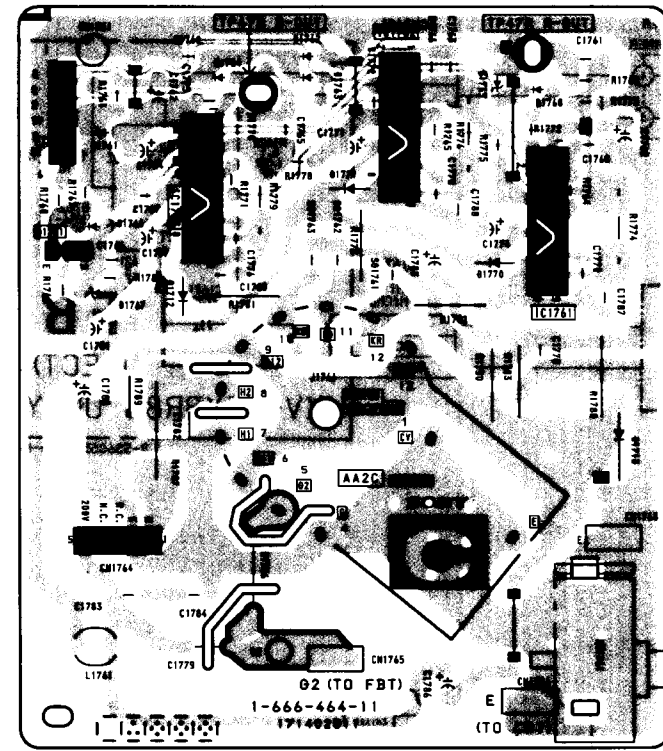

• C BOARD WAVEFORMS

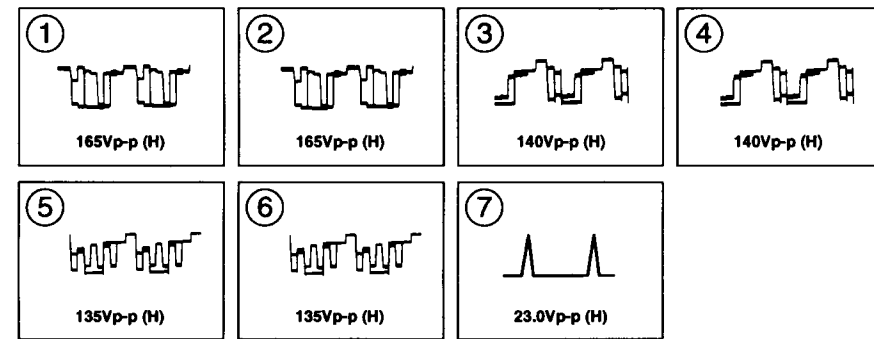

C BOARD : IC1761, 1762, 1763 TDA6101Q/N3

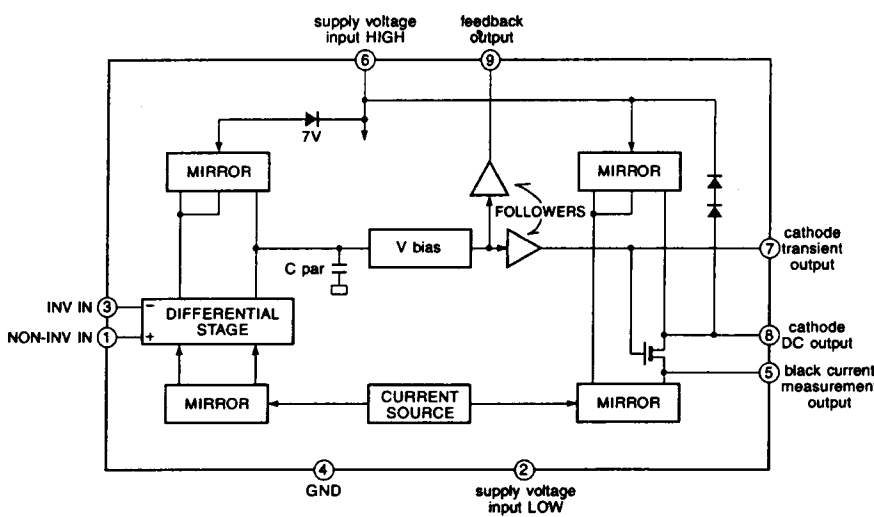

G [AC RECT, DC-DC CONV, LOW B REG]

- G BOARD -

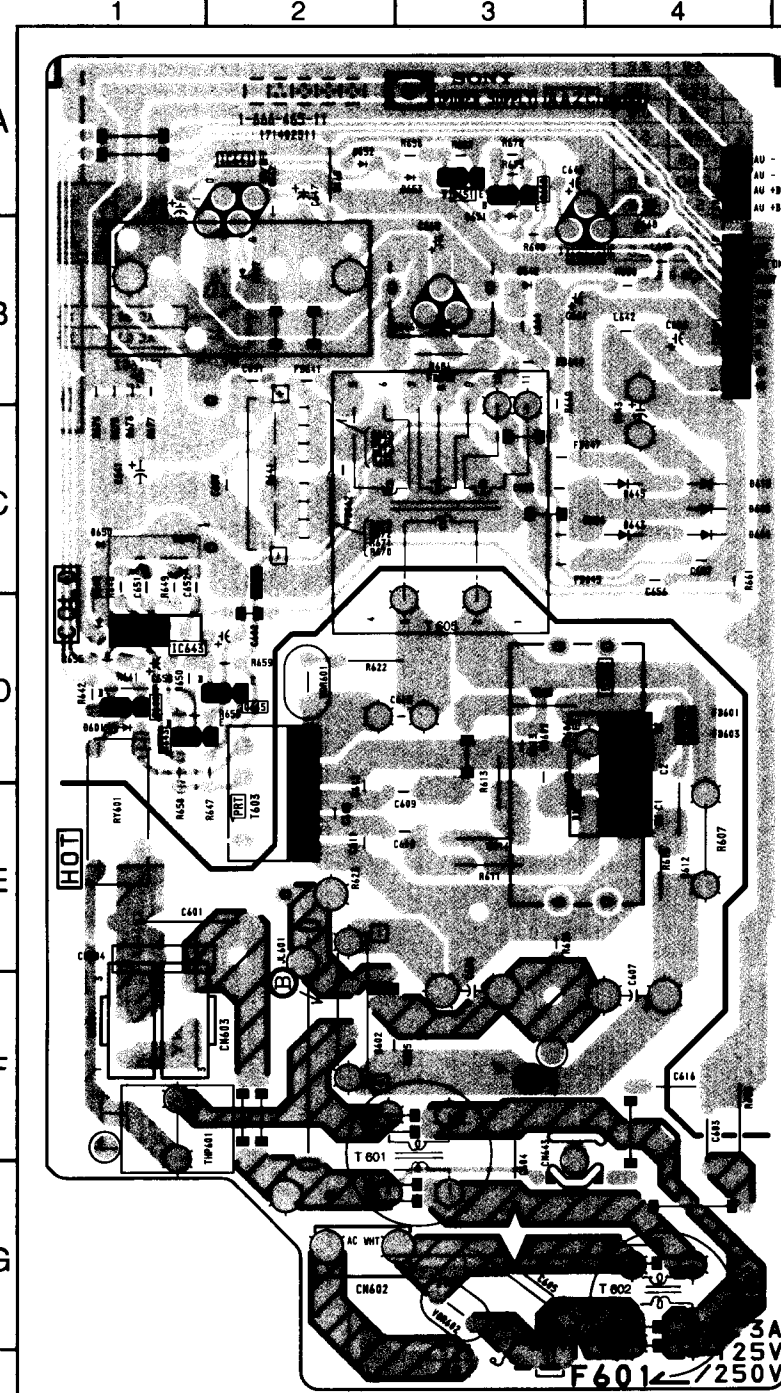

G BOARD

DIODE	
D601	D-1
D602	F-2
D615	C-4
D641	C-2
D642	B-3
D643	C-4
D644	C-4
D645	C-4
D646	B-3
D647	B-2
D648	C-4
D649	D-1
D650	C-1
D651	A-3
D652	A-2
D653	A-3

I C	
IC801	D-4
IC641	A-2
IC642	B-3
IC643	D-1

TRANSISTOR	
Q643	D-1
Q644	D-1
Q645	D-2
Q651	A-3
Q652	A-3

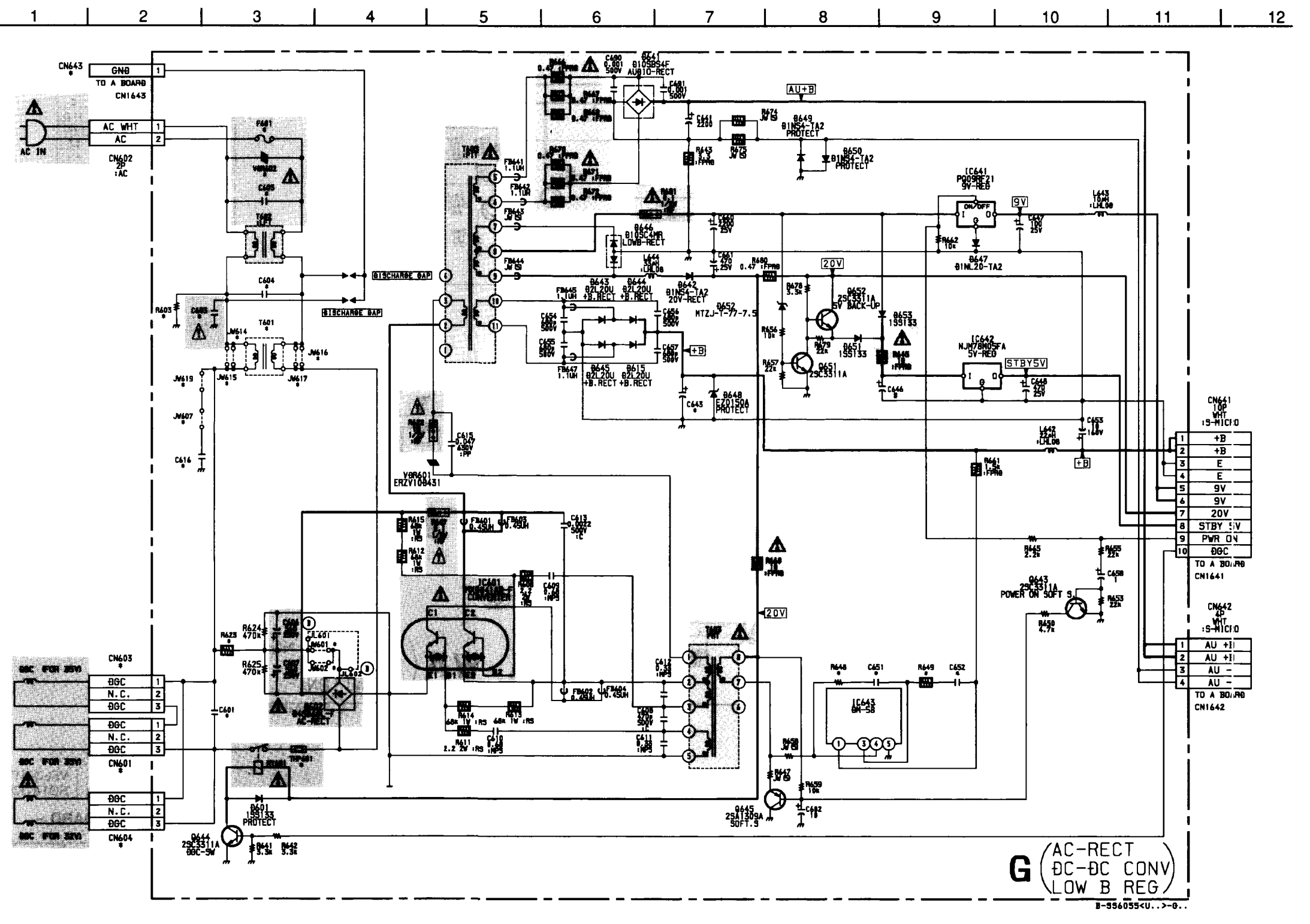

G BOARD * MARK LIST

	KV-35XBR48/35XBR88/37XBR48M	KV-32XBR48	KV-34XBR48C
C801	0.22 250V	-	-
C805	0.47 125V	0.47 125V	0.47 300V
C643	220 160V	220 160V	33 160V : HR
C651	0.0022 : PT	0.0022 : PT	0.01 : PT
C652	0.0022 200V : PT	0.0022 200V : PT	0.001 200V : PT
CN601	3P WHT : MINI	-	-
CN603	3P WHT : MINI	-	-
CN604	-	1-508-765-21	1-508-765-21
F801	6.3A 125V	6.3A 125V	6.3A
JW601	5MM	5MM	-
JW602	5MM	5MM	-
R603	2.2M 1/2W 10% : RC	2.2M 1/2W 10% : RC	8.2M 1W
R623	0.82 20W : RB	0.82 20W : RB	3.3 20W : RB
R648	220K	220K	330K
R649	4.7K : FPRD	4.7K : FPRD	22K : FPRD
T8P601	1-809-539-11	1-809-539-11	1-809-827-11
VDR602	ERZV10D271	ERZV10D471	ERZV10D271
	-	-	- : Not mounted

G BOARD IC VOLTAGE LIST

IC601	B1	-235.0	IC642	I	9.8
	E1	GND		O	5.3
	C1	-23.4		G	GND
	B2	-78.7		I	138.0
	E2	-74.7		3	2.7
	C2	-77.1		4	16.1
	I	11.2		5	GND
	O	9.9			
	G	GND			

All Voltage are in V.
Pin numbers which are not described are not used.

G BOARD TRANSISTOR VOLTAGE LIST

Q643	B	18.1	GND
Q644	0.2	18.1	GND
Q645	18.1	18.1	GND
Q651	0.8	0	GND
Q652	0	18.0	0

All Voltage are in V.

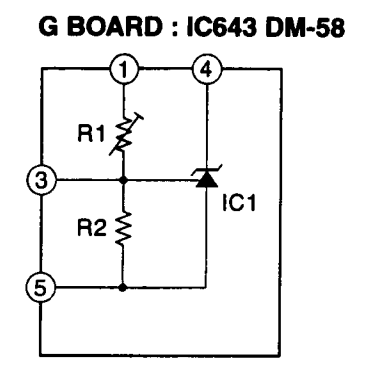

A
B
C
D
E
F
G
H
I
J

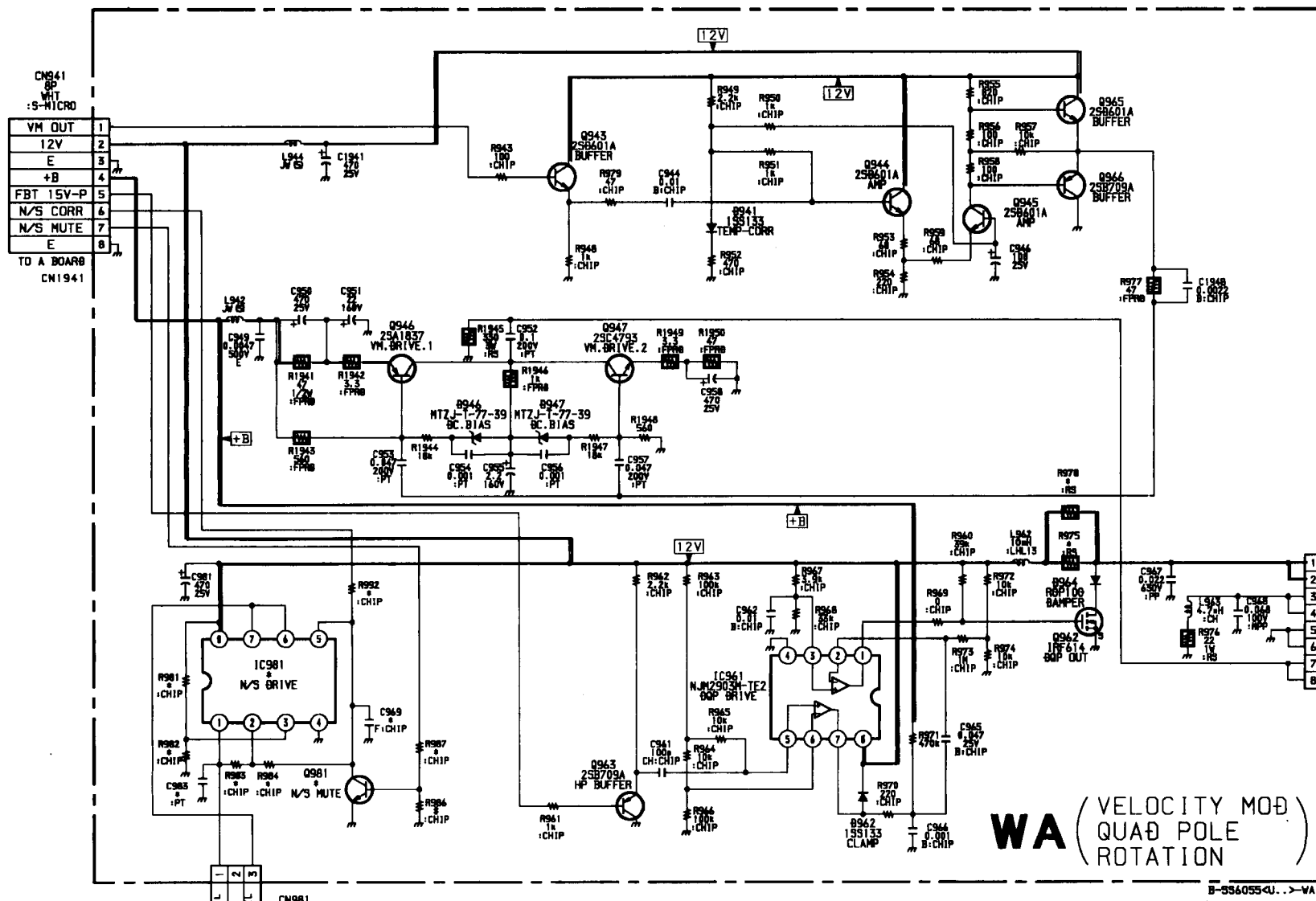

WA BOARD IC VOLTAGE LIST

IC961	1	6.6
	2	6
	3	11.3
	4	GND
IC981	1	5.5
	2	5.2
	3	5.2
	4	GND
IC982	1	5.1
	2	5.1
	3	5.1
	4	GND
IC983	1	5.1
	2	5.1
	3	5.1
	4	GND

All Voltage are in V.
Pin numbers which are not described are not used.

WA BOARD TRANSISTOR VOLTAGE LIST

Q943	B	C	E
	3.2	12.6	2.5
	2.8	12.6	2.2
Q944	2.8	8.6	2.2
	138	89.9	139
Q945	1.1	69.9	0.6
	4.8	GND	5.5
Q946	9.4	12.6	9.0
	8.6	GND	9.0
Q947	0	5.1	GND
	S	D	G
Q948	8.6	6.6	8.6
	GND	8.6	6.6

All Voltage are in V.

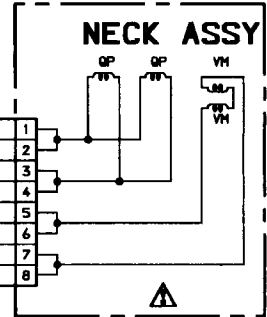

WA [VELOCITY MOD, QUAD POLE, ROTATION]

- WA BOARD -

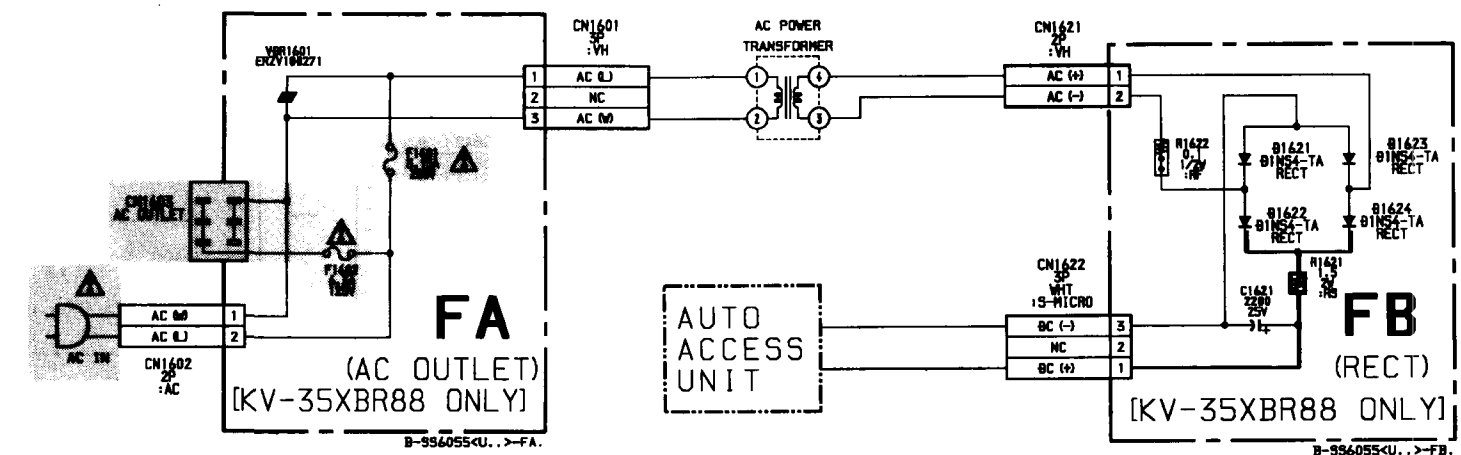
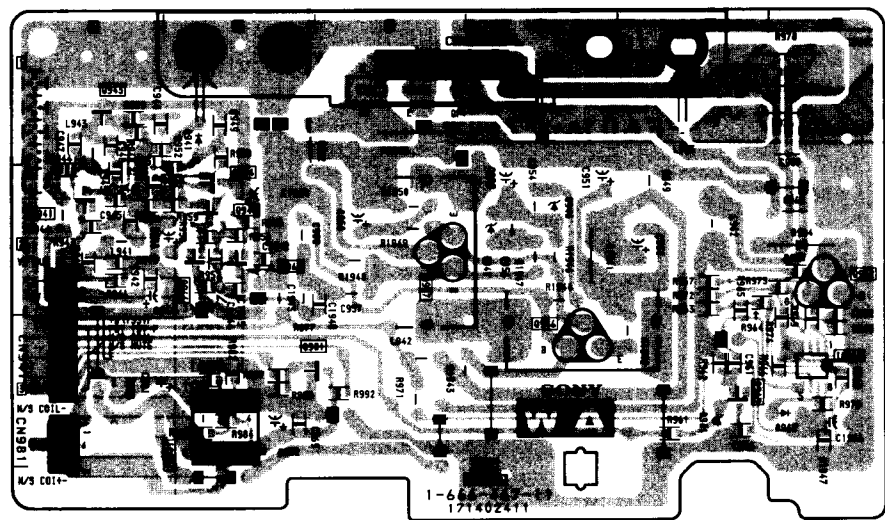

FA [AC OUTLET]

- FA BOARD -

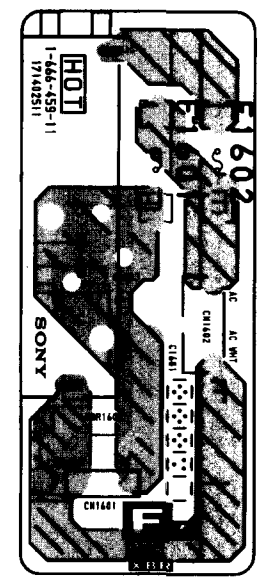

FB [RECT] (KV-35XBR88 ONLY)

- FB BOARD -

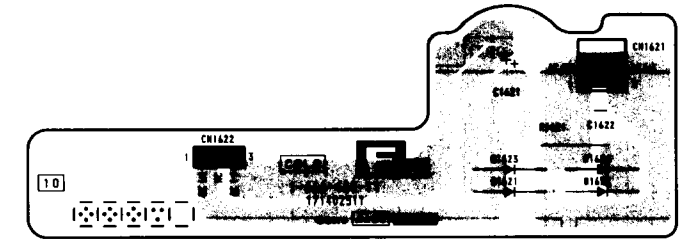

WA BOARD : IC981 M5216P

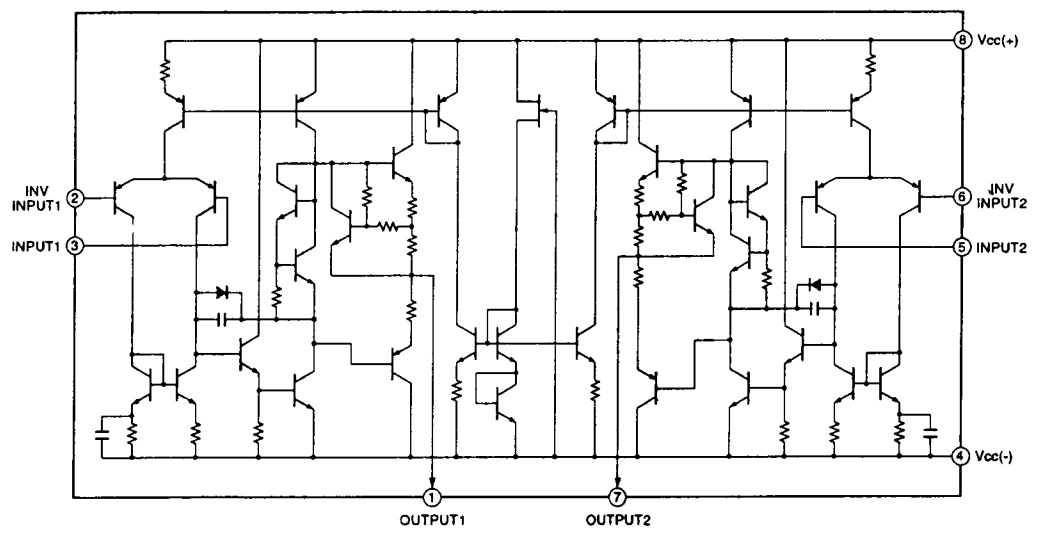

WA BOARD * MARK LIST

	KV-35XBR48/35XBR88/37XBR48M	KV-32XBR48/34XBR48C
C969	0.047 F : CHIP	-
C983	0.0022 : PT	-
CN981	3P WHT : S-MICRO	-
IC981	M5216P	-
Q981	2SD601A	-
R975	68 2W : RS	100 2W : RS
R978	68 2W : RS	100 2W : RS
R981	33K : CHIP	-
R982	22K : CHIP	-
R983	15K : CHIP	-
R984	6.8K : CHIP	-
R987	1K : CHIP	-
R992	-	10K : CHIP
		- : Not mounted

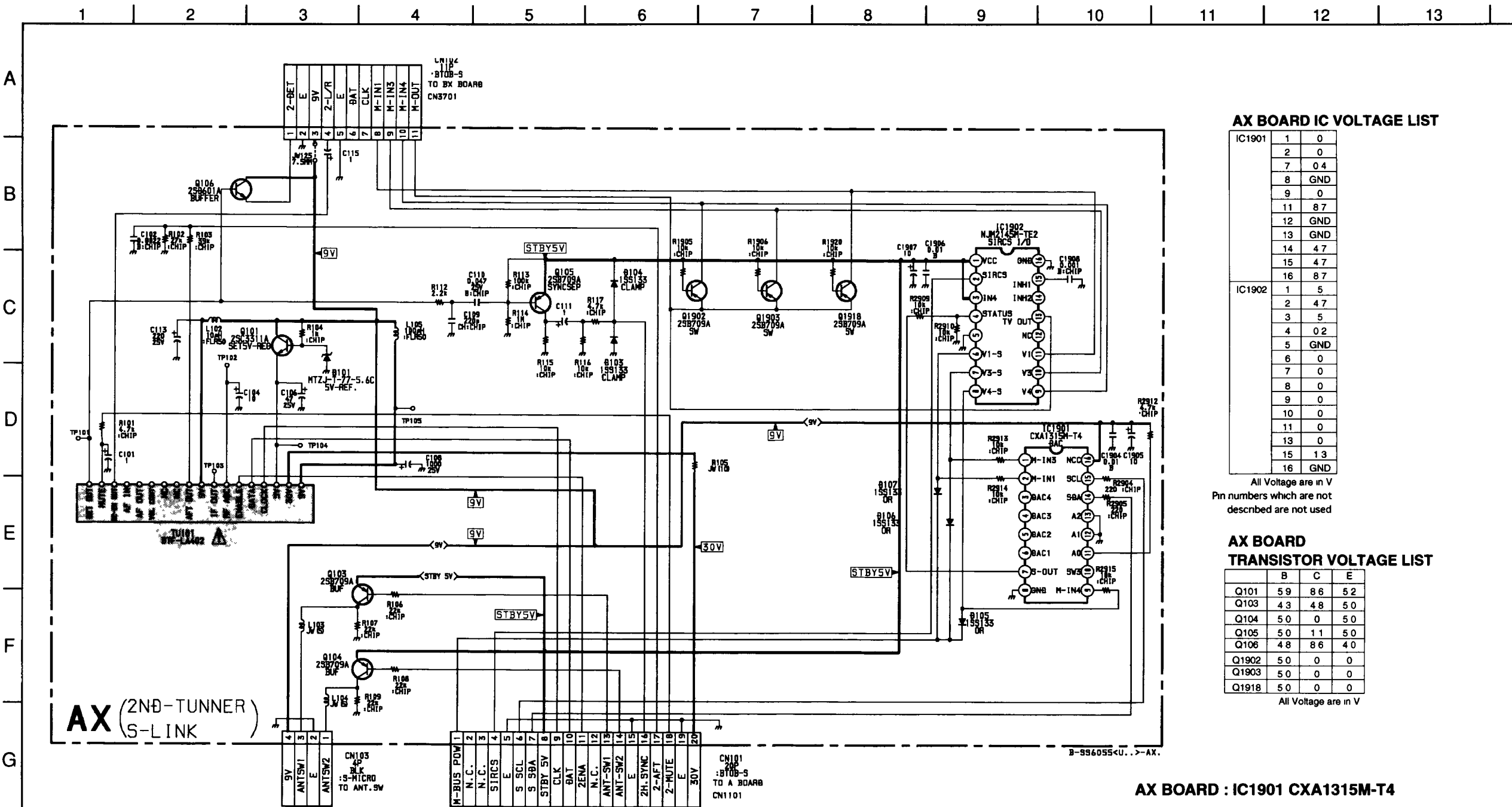

AX (2ND-TUNER)
S-LINK

AX BOARD IC VOLTAGE LIST

IC1901	1	0
	2	0
	7	0.4
	8	GND
	9	0
	11	8.7
	12	GND
	13	GND
	14	4.7
	15	4.7
	16	8.7
IC1902	1	5
	2	4.7
	3	5
	4	0.2
	5	GND
	6	0
	7	0
	8	0
	9	0
	10	0
	11	0
	13	0
	15	1.3
	16	GND

All Voltage are in V
Pin numbers which are not
described are not used

**AX BOARD
TRANSISTOR VOLTAGE LIST**

	B	C	E
Q101	5.9	8.6	5.2
Q103	4.3	4.8	5.0
Q104	5.0	0	5.0
Q105	5.0	1.1	5.0
Q106	4.8	8.6	4.0
Q1902	5.0	0	0
Q1903	5.0	0	0
Q1918	5.0	0	0

All Voltage are in V

AX BOARD : IC1901 CXA1315M-T4

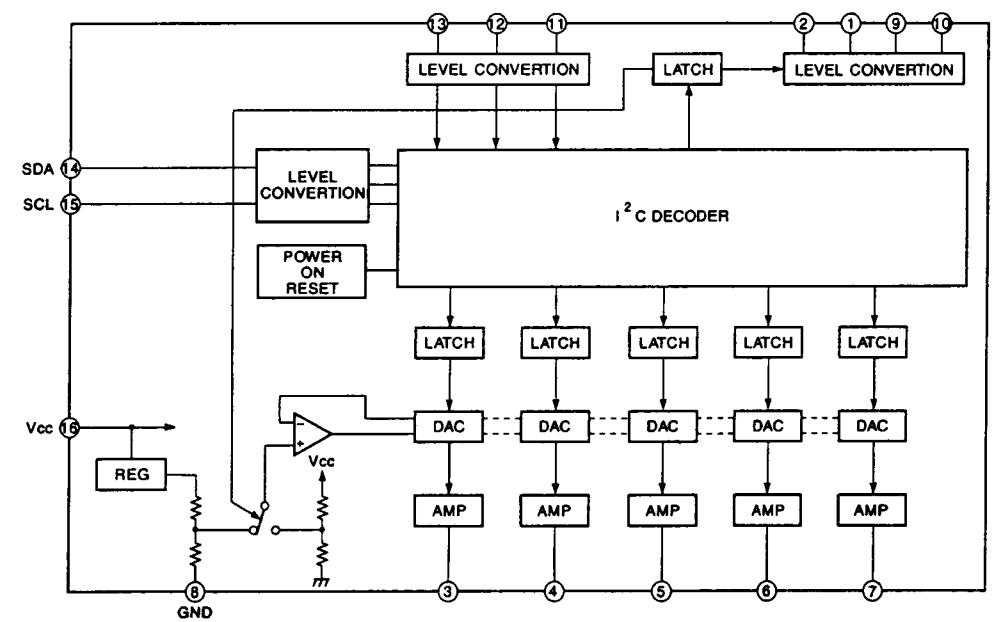

AX [2ND TUNER, S-LINK]

- AX BOARD -

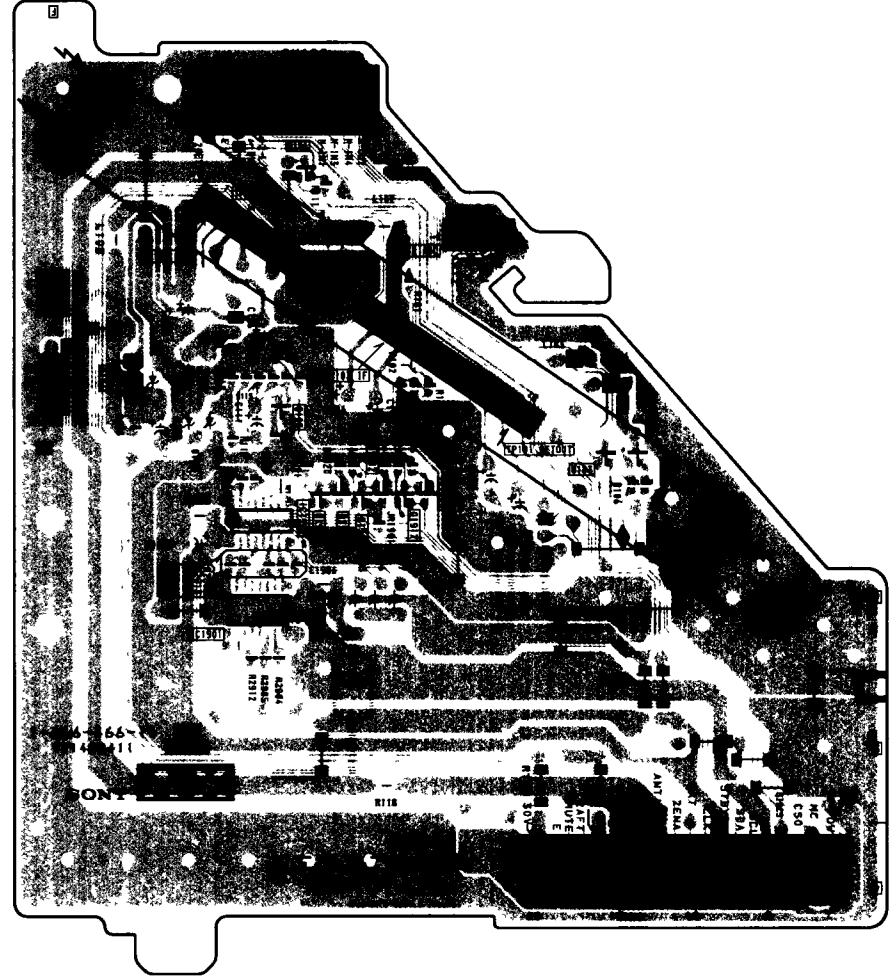

5-4. SEMICONDUCTORS

BU4053BCF-T2
CXA1315M
MC14052BF
NJM2145M-TE2

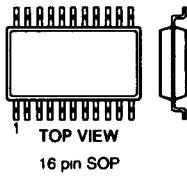

MN47V76ST1
MN47V77ST1

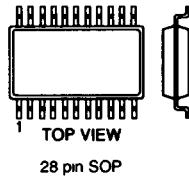

TDA7262

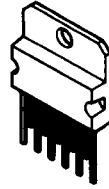

2SA1837
2SC4159-E
2SC4793
2SD2012



EGP20G
ERC06-15S

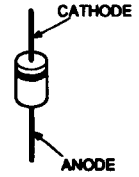

CXA1845Q

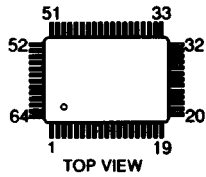

NJM2902M

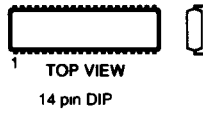

TDA8172



2SC3209LK



MA111
RD3.3SB
1SS355

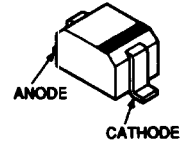

CXA2019Q

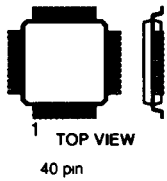

NJM2903M
NJM2904M
ST24C02FM6TR
 μ PC4558G2
X24C04SB

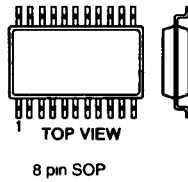

μ PC1862GS-E2

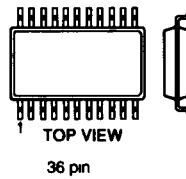

D1NL20
D2L20U
EL1Z
EGP30D
ERD29-08J
EZ0150AV1
GP08D
MTZJ-T-9110
MTZJ-33A
1SS83

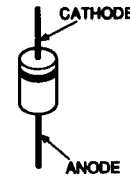

CXA2025AS

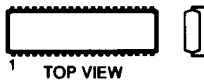

NJM78M05FA
PQ09RF21
TA7805S

IRF614



D1NS4
MTZJ-7.5B
MTZJ-T-77-13A
RD10ESB2
RD33ESB1
RD3.9ES-B1
RD5.6ESB2
RD5.6ESB3
1SS119-25
1SS133T-77

CXA2039M-T6

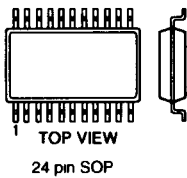

SAB9076AH
 μ PD6488GF-33A

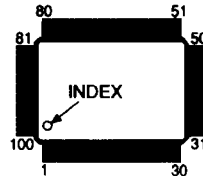

2SA1037K-T146-R
2SA1162-G
2SA1330-06
2SC1623-L5L6
2SD601A-Q

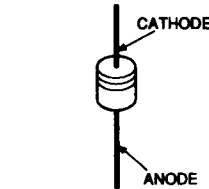

CXP85856A-001S

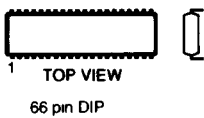

DM-58

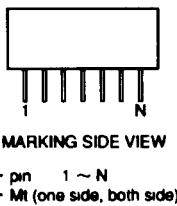

SBX1981-51

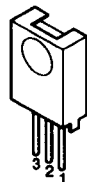

2SA1175-HFE
2SA933AS-QRT
2SC2785-HFE

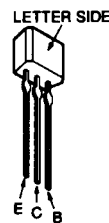

D10SBS4F
D6SB60L



HM538253BJ-7Z

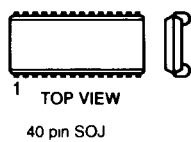

TDA6101Q/N3

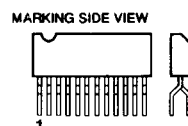

D10SC4MR



SECTION 6

EXPLODED VIEWS

NOTE:

• Items with no part number and no description are not stocked because they are seldom required for routine service.

• The construction parts of an assembled part are indicated with a collation number in the remark column.

• Items marked " * " are not stocked since they are seldom required for routine service. Some delay should be anticipated when ordering these items.

The components identified by shading and mark Δ are critical for safety. Replace only with part number specified.

Les composants identifiés par une trame et une marque Δ sont critiques pour la sécurité. Ne les remplacer que par une pièce portant le numéro spécifié.

6-1. CHASSIS

- : 7-685-648-79 +BVTP 3X12
- ▲ : 7-685-661-79 +BVTP 4X12
- : 7-685-663-79 +BVTP 4X16
- △ : 7-685-666-79 +BVTP 4X30

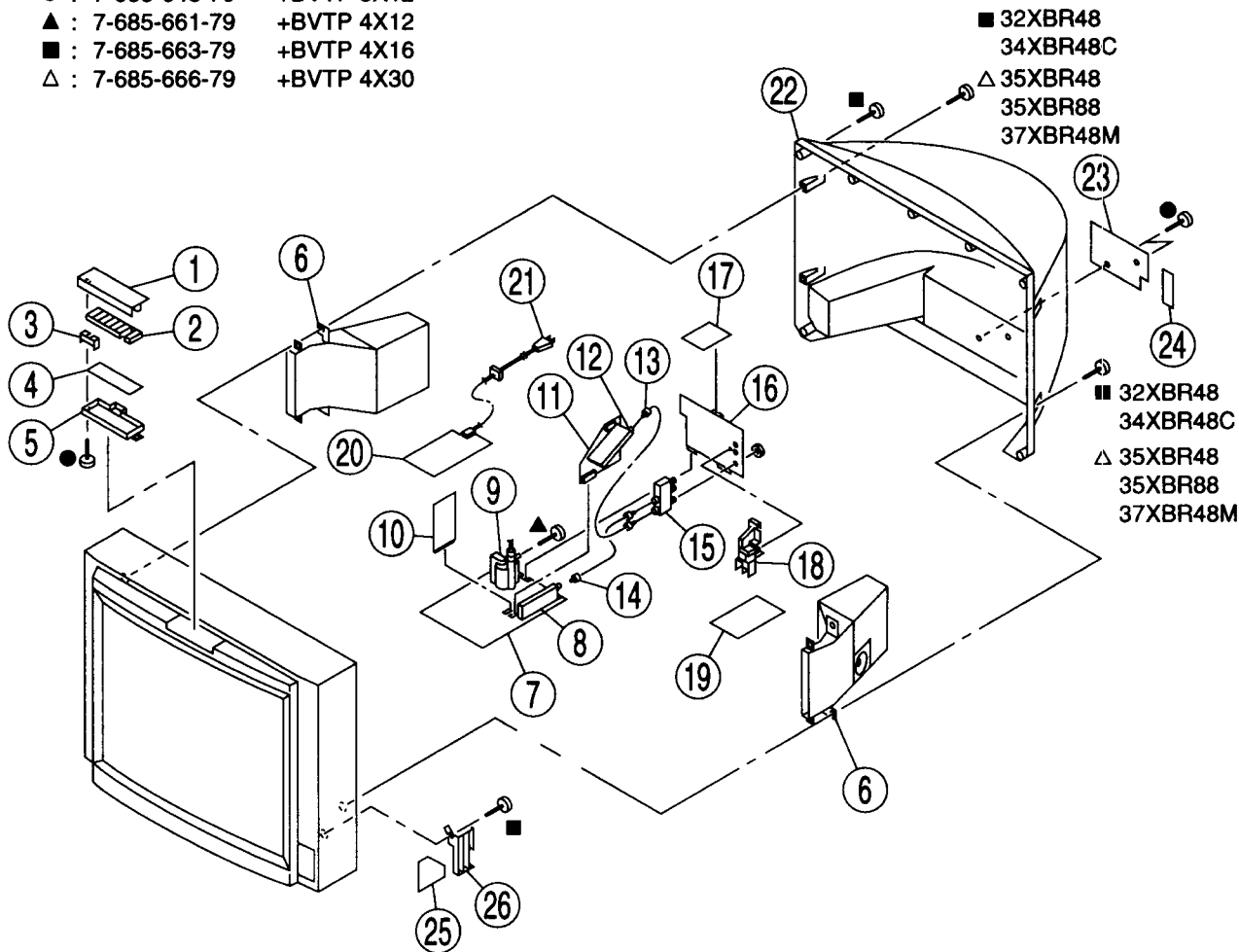

REF NO	PART NO	DESCRIPTION	REMARK	REF NO	PART NO	DESCRIPTION	REMARK
1	4-059-505-01	PANEL, CONTROL		14	* 1-556-945-21	CABLE, P-P	
2	4-059-506-01	BUTTON, MULTI		15	8-598-414-00	ANTENNA SWITCH AS-2F	
3	* 4-059-512-01	GUIDE, LED		16	* A-1394-860-A	UX BOARD, COMPLETE	
4	* A-1372-350-A	HX BOARD, COMPLETE		17	* A-1135-902-A	BX BOARD, COMPLETE	
5	* 4-059-504-01	BRACKET, HX		18	* 4-052-905-01	V5/6 BRACKET	
6	1-505-684-11	SPEAKER UNIT, BOX TYPE (KV-35XBR48/35XBR88/37XBR48M)		19	* A-1380-540-A	K BOARD, COMPLETE	
	1-505-721-11	BOX TYPE, SPEAKER UNIT (KV-32XBR48/34XBR48C)		20	* A-1316-323-A	G BOARD, COMPLETE (KV-35XBR48/35XBR88/37XBR48M)	
7	* A-1298-140-A	A BOARD, COMPLETE (KV-35XBR48/35XBR88/37XBR48M)			* A-1316-324-A	G BOARD, COMPLETE (KV-32XBR48)	
	* A-1298-141-A	A BOARD, COMPLETE (KV-32XBR48/34XBR48C)			* A-1316-331-A	G BOARD, COMPLETE (KV-34XBR48C)	
8	Δ 8-598-340-20	TUNER, FSS BTF-WA404		21	Δ 1-751-059-11	CORD, POWER (WITH CONNECTOR) 10A/125V (except KV-34XBR48C)	
9	Δ 1-453-244-11	TRANSFORMER ASSY, FLYBACK (NX-2612//X4C) (KV-32XBR48/34XBR48C)			Δ 1-769-796-41	COARD, POWER (WITH CONNECTOR) (KV-34XBR48C)	
	Δ X-4034-797-1	TRANSFORMER ASSY, FLYBACK (NX-3005//J1C) (KV-35XBR48/35XBR88/37XBR48M)		22	4-059-495-01	COVER, REAR (KV-32XBR48/34XBR48C)	
10	* A-1195-121-A	PX BOARD, COMPLETE			4-059-503-01	COVER, REAR (KV-35XBR48/35XBR88/37XBR48M)	
11	* A-1298-139-A	AX BOARD, COMPLETE		23	4-059-499-01	LABEL, TERMINAL	
12	Δ 8-598-339-20	TUNER, FSS BTF-LA402		24	4-059-500-01	LABEL, ANTENNA	
13	* 1-557-056-31	CABLE, P-P		25	* A-1372-351-A	HF BOARD, COMPLETE	
				26	* 4-059-501-01	BRACKET, HF (KV-35XBR48/35XBR88/37XBR48M)	
					* 4-059-920-01	BRACKET, HF (KV-32XBR48/34XBR48C)	

The components identified by shading and mark **△** are critical for safety
 Replace only with part number specified

Les composants identifiés par une trame et une marque **△** sont critiques pour la sécurité
 Ne les remplacer que par une pièce portant le numéro spécifié

6-2. PICTURE TUBE

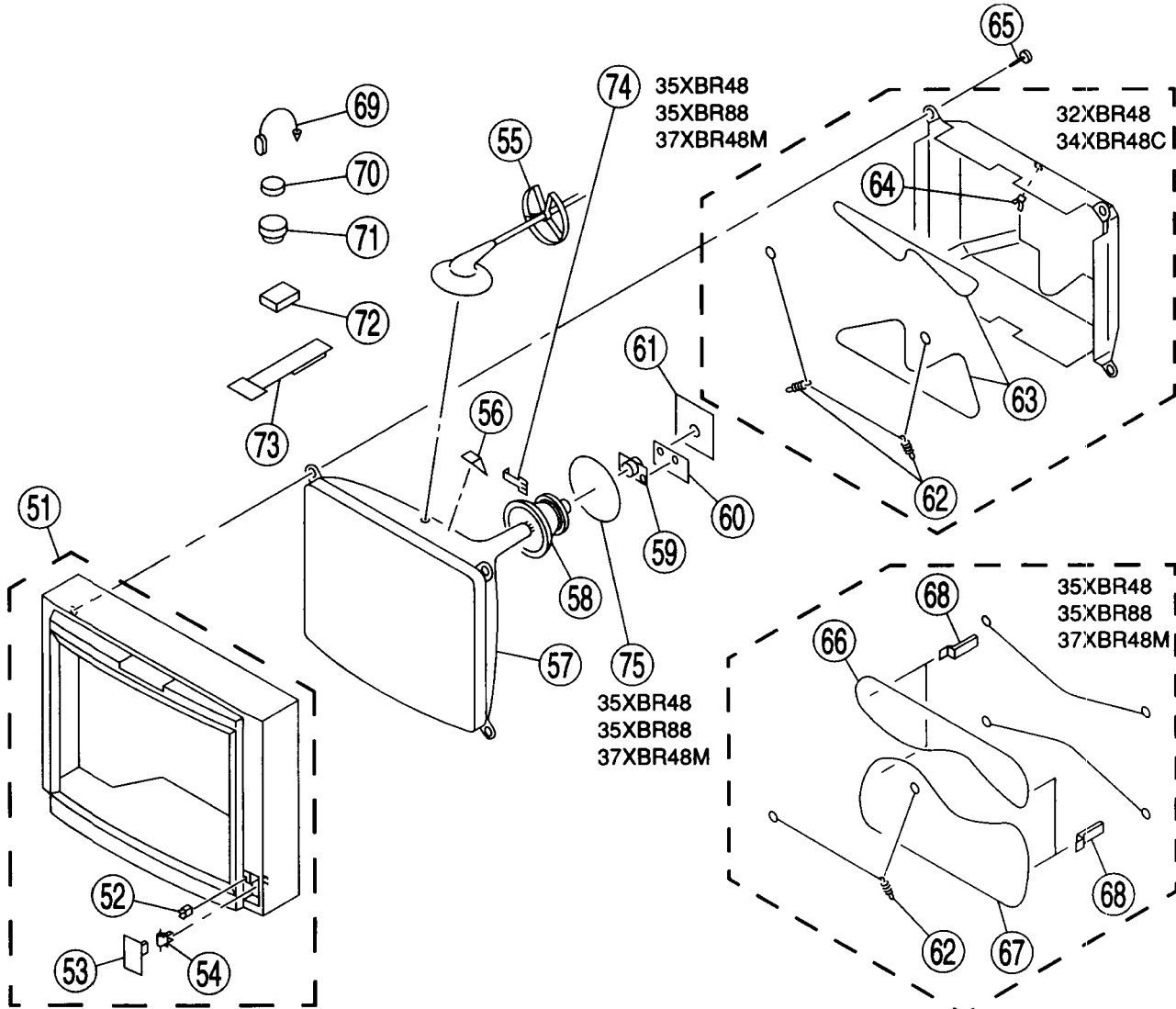

REF NO	PART NO	DESCRIPTION	REMARK	REF. NO	PART NO	DESCRIPTION	REMARK
51	X-4034-634-1	BEZNET ASSY (KV-32XBR48/34XBR48C)	52-54	61	* A-1331-692-A	C BOARD, COMPLETE	
	X-4034-635-1	BEZNET ASSY (KV-35XBR48/35XBR88/37XBR48M)	52-54			(KV-35XBR48/35XBR88/37XBR48M)	
52	4-392-036-01	CATCHER, PUSH		62	* A-1331-694-A	C BOARD, COMPLETE (KV-32XBR48/34XBR48C)	
53	4-059-497-01	DOOR, CONTROL		63	4-036-329-01	SPRING (B), TENSION	
54	4-045-250-31	DAMPER		63	△ 1-402-952-12	COIL, DEMAGNETIZATION (KV-32XBR48)	
55	3-704-372-31	HOLDER, HV CABLE			△ 1-411-474-11	COIL, DEMAGNETIZATION (KV-34XBR48C)	
56	4-053-005-01	SPACER, DY (KV-32XBR48/34XBR48C)		64	* 4-371-629-01	STOPPER, WIRE (KV-32XBR48/34XBR48C)	
	4-053-093-01	SPACER DY (KV-35XBR48/35XBR88/37XBR48M)		65	4-041-268-01	SCREW (7), TAPPING (KV-32XBR48/34XBR48C)	
57	△ 8-733-745-05	PICTURE TUBE 34FXD2(SDP) (XBR) (M80JYV51X) (KV-32XBR48)			4-046-765-01	SCREW, TAPPING (KV-35XBR48/35XBR88/37XBR48M)	
	△ 8-733-760-05	PICTURE TUBE 37GX (A89LJT80X) (KV-35XBR48/35XBR88/37XBR48M)		66	△ 1-411-881-12	COIL, DEMAGNETIC (KV-35XBR48/35XBR88/37XBR48M)	
	△ 8-735-746-05	PICTURE TUBE 34FXD2 (SDP) (FOR XBR/10UT) (M80JYV51X) (KV-34XBR48C)		67	△ 1-411-882-12	COIL, DEMAGNETIC (KV-35XBR48/35XBR88/37XBR48M)	
58	△ 8-451-480-11	DEFLECTION YOKE Y37GXA-X (KV-35XBR48/35XBR88/37XBR48M)		68	* 4-052-900-01	HOLDER, DGC (KV-35XBR48/35XBR88/37XBR48M)	
	△ 8-451-482-21	DEFLECTION YOKE Y34FXA2-X (KV-32XBR48/34XBR48C)		69	4-308-870-00	CLIP, LEAD WIRE	
59	△ 8-453-007-21	NA324-M2		70	1-452-032-00	MAGNET, DISK , 10mmø	
60	* A-1372-348-A	WA BOARD, COMPLETE (KV-35XBR48/35XBR88/37XBR48M)		71	1-452-094-00	MAGNET, ROTABLE DISK , 15mmø	
	* A-1372-352-A	WA BOARD, COMPLETE (KV-32XBR48/34XBR48C)		72	1-452-885-11	MAGNET, LANDING (KV-32XBR48/34XBR48C)	
				73	4-051-737-21	PIECE A(100), CONV CORRECT	
				74	4-034-272-51	REVIISED BOARD, TLV (KV-35XBR48/35XBR88/37XBR48M)	
				75	1-452-724-11	COIL, NA ROTATION (KV-35XBR48/35XBR88/37XBR48M)	

The components identified by shading and mark Δ are critical for safety
Replace only with part number specified

Les composants identifiés par une trame et une marque Δ sont critiques pour la sécurité
Ne les remplacer que par une pièce portant le numéro spécifié

6-3. CABINET BASE (KV-35XBR88)

- : 7-685-648-79 +BVTP 3X12
- ▲ : 7-685-661-79 +BVTP 4X12
- : 7-685-663-79 +BVTP 4X16

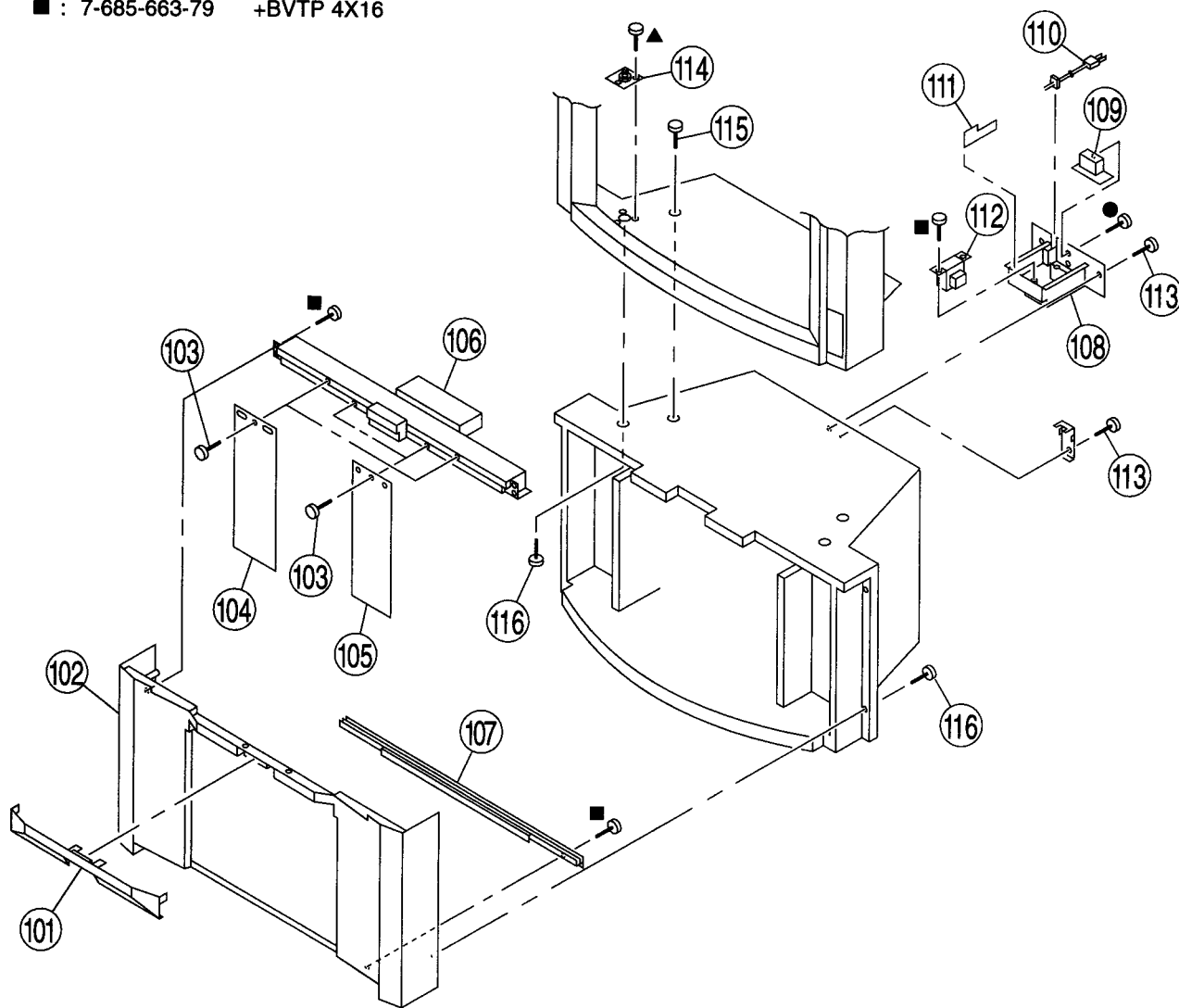

REF. NO	PART NO	DESCRIPTION	REMARK	REF. NO	PART NO.	DESCRIPTION	REMARK
101	4-059-614-01	CONTROL PANEL, STAND		110	Δ 1-751-059-11	CORD, POWER (WITH CONNECTOR)	10A/125V
102	4-059-613-01	PANEL, FRONT		111	* A-1241-294-A	FB BOARD, COMPLETE	
103	4-060-204-01	SCREW, HANGER		112	1-431-520-11	TRANSFORMER, POWER	
104	4-060-203-01	PLATE, DOOR (OUT)		113	4-041-164-11	SCREW (4X20), TAPPING	
105	4-060-202-01	PLATE, DOOR (IN)		114	4-060-201-01	NUT, CONSOLE CLAMP	
106	1-475-319-11	DOOR UNIT, AUTO		115	4-046-765-01	SCREW, TAPPING	
107	4-060-197-01	RAIL, GUIDE		116	4-052-748-11	BOLT, +HX HEAD WITH WASHER	
108	4-059-615-01	CASE, AC OUTLET					
109	* A-1241-293-A	FA BOARD, COMPLETE					

SECTION 7

ELECTRICAL PARTS LIST

BX

NOTE:

Les composants identifiés par une trame et une marque Δ sont critiques pour la sécurité. Ne les remplacer que par une pièce portant le numéro spécifié.

The components identified by shading and mark Δ are critical for safety. Replace only with part number specified

• The components identified by \square in this manual have been carefully factory-selected for each set in order to satisfy regulations regarding X-ray radiation. Should replacement be required, replace only with the value originally used.

• Items marked " * " are not stocked since they are seldom required for routine service. Some delay should be anticipated when ordering these items.

• All variable and adjustable resistors have characteristic curve B, unless otherwise noted.

RESISTORS

- All resistors are in ohms
- F : nonflammable

When indicating parts by reference number, please include the board name.

• CAPACITORS
PF : $\mu\mu$ F

• There are some cases the reference number on one board overlaps on the other board. Therefore, when ordering parts by the reference number, please include the board name.

REF. NO.	PART NO.	DESCRIPTION	REMARK	REF. NO.	PART NO.	DESCRIPTION	REMARK
* A-1135-902-A BX BOARD, COMPLETE *****				C3777	1-163-038-91	CERAMIC CHIP 0 1MF	25V
<CAPACITOR>				C3778	1-104-664-11	ELECT 47MF	20% 25V
C3701	1-104-664-11	ELECT 47MF	20% 25V	C3779	1-163-038-91	CERAMIC CHIP 0.1MF	25V
C3703	1-163-231-11	CERAMIC CHIP 15PF	5% 50V	C3780	1-163-038-91	CERAMIC CHIP 0.1MF	25V
C3704	1-104-664-11	ELECT 47MF	20% 25V	C3781	1-163-038-91	CERAMIC CHIP 0.1MF	25V
C3706	1-104-664-11	ELECT 47MF	20% 25V	C3782	1-163-038-91	CERAMIC CHIP 0 1MF	25V
C3707	1-163-038-91	CERAMIC CHIP 0 1MF	25V	C3784	1-163-038-91	CERAMIC CHIP 0.1MF	25V
C3708	1-104-664-11	ELECT 47MF	20% 25V	C3785	1-164-232-11	CERAMIC CHIP 0.01MF	10% 50V
C3709	1-163-038-91	CERAMIC CHIP 0 1MF	25V	C3786	1-126-964-11	ELECT 10MF	20% 50V
C3710	1-104-664-11	ELECT 47MF	20% 25V	C3787	1-163-038-91	CERAMIC CHIP 0.1MF	25V
C3711	1-163-038-91	CERAMIC CHIP 0.1MF	25V	C3788	1-163-038-91	CERAMIC CHIP 0.1MF	25V
C3712	1-126-961-11	ELECT 2 2MF	20% 50V	C3789	1-163-038-91	CERAMIC CHIP 0.1MF	25V
C3713	1-163-038-91	CERAMIC CHIP 0 1MF	25V	C3790	1-163-038-91	CERAMIC CHIP 0.1MF	25V
C3722	1-126-959-11	ELECT 0 47MF	20% 50V	C3791	1-163-038-91	CERAMIC CHIP 0.1MF	25V
C3723	1-163-131-00	CERAMIC CHIP 390PF	5% 50V	C3792	1-164-004-11	CERAMIC CHIP 0.1MF	10% 25V
C3724	1-164-232-11	CERAMIC CHIP 0 01MF	10% 50V	C3827	1-163-038-91	CERAMIC CHIP 0 1MF	25V
C3725	1-164-232-11	CERAMIC CHIP 0.01MF	10% 50V	C3828	1-164-232-11	CERAMIC CHIP 0.01MF	10% 50V
C3727	1-163-038-91	CERAMIC CHIP 0.1MF	25V	C3829	1-126-964-11	ELECT 10MF	20% 50V
C3728	1-163-037-11	CERAMIC CHIP 0 022MF	10% 50V	C3830	1-163-038-91	CERAMIC CHIP 0.1MF	25V
C3729	1-126-963-11	ELECT 4 7MF	20% 50V	C3831	1-126-964-11	ELECT 10MF	20% 50V
C3730	1-163-239-11	CERAMIC CHIP 33PF	5% 50V	C3832	1-126-964-11	ELECT 10MF	20% 50V
C3731	1-163-235-11	CERAMIC CHIP 22PF	5% 50V	C3833	1-126-964-11	ELECT 10MF	20% 50V
C3732	1-163-235-11	CERAMIC CHIP 22PF	5% 50V	C3834	1-164-232-11	CERAMIC CHIP 0.01MF	10% 50V
C3733	1-164-232-11	CERAMIC CHIP 0.01MF	10% 50V	C3835	1-126-960-11	ELECT 1MF	20% 50V
C3734	1-126-964-11	ELECT 10MF	20% 50V	C3836	1-128-551-11	ELECT 22MF	20% 25V
C3735	1-163-038-91	CERAMIC CHIP 0.1MF	25V	<CONNECTOR>			
C3736	1-163-038-91	CERAMIC CHIP 0 1MF	25V	CN3701	1-573-978-21	CONNECTOR, BOARD TO BOARD 11P	
C3737	1-126-964-11	ELECT 10MF	20% 50V	CN3702	1-573-297-21	CONNECTOR, BOARD TO BOARD 18P	
C3739	1-163-009-11	CERAMIC CHIP 0.001MF	10% 50V	<DIODE>			
C3741	1-163-009-11	CERAMIC CHIP 0.001MF	10% 50V	D3704	8-719-404-49	DIODE MA111	
C3742	1-164-232-11	CERAMIC CHIP 0.01MF	10% 50V	D3705	8-719-404-49	DIODE MA111	
C3743	1-163-259-91	CERAMIC CHIP 220PF	5% 50V	D3706	8-719-404-49	DIODE MA111	
C3744	1-163-011-11	CERAMIC CHIP 0 0015MF	10% 50V	D3707	8-719-404-49	DIODE MA111	
C3745	1-126-963-11	ELECT 4 7MF	20% 50V	D3708	8-719-404-49	DIODE MA111	
C3746	1-164-232-11	CERAMIC CHIP 0 01MF	10% 50V	<FERRITE BEAD>			
C3747	1-164-232-11	CERAMIC CHIP 0 01MF	10% 50V	FB3701	1-412-911-11	INDUCTOR, FERRITE BEAD	
C3755	1-163-038-91	CERAMIC CHIP 0 1MF	25V	FB3702	1-216-295-91	CONDUCTOR, CHIP	
C3756	1-104-664-11	ELECT 47MF	20% 25V	FB3703	1-216-295-91	CONDUCTOR, CHIP	
C3758	1-163-231-11	CERAMIC CHIP 15PF	5% 50V	FB3706	1-216-295-91	CONDUCTOR, CHIP	
C3759	1-104-664-11	ELECT 47MF	20% 25V	FB3707	1-216-295-91	CONDUCTOR, CHIP	
C3763	1-163-231-11	CERAMIC CHIP 15PF	5% 50V	FB3708	1-216-295-91	CONDUCTOR, CHIP	
C3764	1-164-232-11	CERAMIC CHIP 0 01MF	10% 50V	<FILTER>			
C3766	1-163-038-91	CERAMIC CHIP 0.1MF	25V	FL3702	1-239-847-11	FILTER, LOW PASS	
C3768	1-126-964-11	ELECT 10MF	20% 50V	FL3704	1-239-847-11	FILTER, LOW PASS	
C3770	1-163-038-91	CERAMIC CHIP 0 1MF	25V	FL3705	1-239-847-11	FILTER, LOW PASS	
C3771	1-163-038-91	CERAMIC CHIP 0.1MF	25V	FL3706	1-236-101-11	ENCAPSULATED COMPONENT	
C3772	1-163-038-91	CERAMIC CHIP 0 1MF	25V	FL3707	1-236-101-11	ENCAPSULATED COMPONENT	
C3773	1-163-038-91	CERAMIC CHIP 0 1MF	25V				
C3774	1-126-964-11	ELECT 10MF	20% 50V				
C3775	1-163-038-91	CERAMIC CHIP 0.1MF	25V				
C3776	1-126-961-11	ELECT 2.2MF	20% 50V				

BX

REF. NO.	PART NO.	DESCRIPTION	REMARK	REF NO	PART NO	DESCRIPTION	REMARK
		<IC>		R3759	1-216-097-91	METAL GLAZE 100K	5% 1/10W
IC3702	8-759-701-56	IC NJM78M05FA		R3760	1-216-053-00	METAL GLAZE 1.5K	5% 1/10W
IC3703	8-759-445-59	IC BA033T		R3761	1-216-057-00	METAL GLAZE 2.2K	5% 1/10W
IC3705	8-759-296-53	IC uPC1862GS-E2		R3762	1-216-035-00	METAL GLAZE 270	5% 1/10W
IC3707	8-759-444-12	IC uPD6488GF-3BA		R3763	1-216-059-00	METAL GLAZE 2.7K	5% 1/10W
IC3708	8-759-429-95	IC MN47V76ST1		R3764	1-216-071-00	METAL GLAZE 8.2K	5% 1/10W
IC3709	8-759-422-80	IC MN47V77ST1		R3771	1-216-029-00	METAL GLAZE 150	5% 1/10W
		<CHIP CONDUCTOR>		R3772	1-208-784-11	METAL GLAZE 1.2K	0.50% 1/10W
JR3710	1-216-295-91	CONDUCTOR, CHIP		R3773	1-208-806-11	METAL GLAZE 10K	0.50% 1/10W
JR3712	1-216-295-91	CONDUCTOR, CHIP		R3774	1-208-814-11	METAL GLAZE 22K	0.50% 1/10W
JR3714	1-216-295-91	CONDUCTOR, CHIP		R3775	1-216-029-00	METAL GLAZE 150	5% 1/10W
		<COIL>		R3776	1-208-788-11	METAL GLAZE 1.8K	0.50% 1/10W
L3701	1-410-470-11	INDUCTOR 10UH		R3777	1-208-814-11	METAL GLAZE 22K	0.50% 1/10W
L3702	1-410-470-11	INDUCTOR 10UH		R3778	1-216-073-00	METAL GLAZE 10K	5% 1/10W
L3706	1-410-470-11	INDUCTOR 10UH		R3782	1-216-295-91	CONDUCTOR, CHIP	
L3708	1-410-470-11	INDUCTOR 10UH		R3783	1-216-097-91	METAL GLAZE 100K	5% 1/10W
L3709	1-410-466-41	INDUCTOR 4.7UH		R3784	1-216-001-00	METAL GLAZE 10	5% 1/10W
L3714	1-410-470-11	INDUCTOR 10UH		R3788	1-216-043-91	METAL GLAZE 560	5% 1/10W
		<TRANSISTOR>		R3789	1-216-071-00	METAL GLAZE 8.2K	5% 1/10W
Q3701	8-729-026-49	TRANSISTOR 2SA1037AK-T146-R		R3790	1-216-091-00	METAL GLAZE 56K	5% 1/10W
Q3702	8-729-026-49	TRANSISTOR 2SA1037AK-T146-R		R3791	1-216-081-00	METAL GLAZE 22K	5% 1/10W
Q3703	8-729-422-27	TRANSISTOR 2SD601A-Q		R3792	1-216-049-91	METAL GLAZE 1K	5% 1/10W
Q3707	8-729-422-27	TRANSISTOR 2SD601A-Q		R3793	1-208-774-11	METAL GLAZE 470	0.50% 1/10W
Q3708	8-729-026-49	TRANSISTOR 2SA1037AK-T146-R		R3794	1-216-025-91	METAL GLAZE 100	5% 1/10W
Q3709	8-729-026-49	TRANSISTOR 2SA1037AK-T146-R		R3795	1-208-782-11	METAL GLAZE 1K	0.50% 1/10W
Q3719	8-729-422-27	TRANSISTOR 2SD601A-Q		R3806	1-216-001-00	METAL GLAZE 10	5% 1/10W
Q3724	8-729-422-27	TRANSISTOR 2SD601A-Q		R3810	1-216-043-91	METAL GLAZE 560	5% 1/10W
Q3725	8-729-026-49	TRANSISTOR 2SA1037AK-T146-R		R3811	1-216-071-00	METAL GLAZE 8.2K	5% 1/10W
Q3728	8-729-026-49	TRANSISTOR 2SA1037AK-T146-R		R3812	1-216-091-00	METAL GLAZE 56K	5% 1/10W
Q3729	8-729-026-49	TRANSISTOR 2SA1037AK-T146-R		R3813	1-216-081-00	METAL GLAZE 22K	5% 1/10W
Q3731	8-729-422-27	TRANSISTOR 2SD601A-Q		R3814	1-216-049-91	METAL GLAZE 1K	5% 1/10W
Q3732	8-729-026-49	TRANSISTOR 2SA1037AK-T146-R		R3815	1-216-041-00	METAL GLAZE 470	5% 1/10W
Q3733	8-729-422-27	TRANSISTOR 2SD601A-Q		R3816	1-216-025-91	METAL GLAZE 100	5% 1/10W
Q3734	8-729-422-27	TRANSISTOR 2SD601A-Q		R3817	1-216-051-00	METAL GLAZE 1.2K	5% 1/10W
		<RESISTOR>		R3858	1-216-025-91	METAL GLAZE 100	5% 1/10W
R3701	1-216-081-00	METAL GLAZE 22K	5% 1/10W	R3859	1-216-025-91	METAL GLAZE 100	5% 1/10W
R3702	1-216-091-00	METAL GLAZE 56K	5% 1/10W	R3880	1-216-049-91	METAL GLAZE 1K	5% 1/10W
R3703	1-216-057-00	METAL GLAZE 2.2K	5% 1/10W	R3881	1-216-049-91	METAL GLAZE 1K	5% 1/10W
R3704	1-216-057-00	METAL GLAZE 2.2K	5% 1/10W	R3884	1-216-041-00	METAL GLAZE 470	5% 1/10W
R3705	1-216-057-00	METAL GLAZE 2.2K	5% 1/10W	R3885	1-216-041-00	METAL GLAZE 470	5% 1/10W
R3706	1-208-750-11	METAL GLAZE 47	0.50% 1/10W	R3886	1-216-105-91	METAL GLAZE 220K	5% 1/10W
R3707	1-208-762-11	METAL GLAZE 150	0.50% 1/10W	R3887	1-216-097-91	METAL GLAZE 100K	5% 1/10W
R3708	1-216-043-91	METAL GLAZE 560	5% 1/10W	R3888	1-216-089-91	METAL GLAZE 47K	5% 1/10W
R3709	1-216-075-00	METAL GLAZE 12K	5% 1/10W	R3889	1-216-025-91	METAL GLAZE 100	5% 1/10W
R3710	1-216-081-00	METAL GLAZE 22K	5% 1/10W	R3890	1-216-097-91	METAL GLAZE 100K	5% 1/10W
R3711	1-216-081-00	METAL GLAZE 22K	5% 1/10W	R3891	1-216-097-91	METAL GLAZE 100K	5% 1/10W
R3717	1-216-049-91	METAL GLAZE 1K	5% 1/10W	R3892	1-216-295-91	CONDUCTOR, CHIP	
R3719	1-208-770-11	METAL GLAZE 330	0.50% 1/10W	R3893	1-216-295-91	CONDUCTOR, CHIP	
R3722	1-216-041-00	METAL GLAZE 470	5% 1/10W	R3894	1-216-295-91	CONDUCTOR, CHIP	
R3746	1-216-041-00	METAL GLAZE 470	5% 1/10W	R3895	1-216-295-91	CONDUCTOR, CHIP	
R3747	1-216-121-91	METAL GLAZE 1M	5% 1/10W	R3896	1-216-017-91	METAL GLAZE 47	5% 1/10W
R3748	1-216-065-00	METAL GLAZE 4.7K	5% 1/10W	R3898	1-216-017-91	METAL GLAZE 47	5% 1/10W
R3749	1-208-775-11	METAL GLAZE 510	0.50% 1/10W	R3900	1-216-295-91	CONDUCTOR, CHIP	
R3750	1-208-758-11	METAL GLAZE 100	0.50% 1/10W	R3901	1-216-295-91	CONDUCTOR, CHIP	
R3751	1-216-009-00	METAL GLAZE 22	5% 1/10W	R3902	1-216-295-91	CONDUCTOR, CHIP	
R3752	1-216-041-00	METAL GLAZE 470	5% 1/10W	R3903	1-216-295-91	CONDUCTOR, CHIP	
R3753	1-216-057-00	METAL GLAZE 2.2K	5% 1/10W	R3904	1-216-295-91	CONDUCTOR, CHIP	
R3754	1-216-041-00	METAL GLAZE 470	5% 1/10W				
R3755	1-216-033-00	METAL GLAZE 220	5% 1/10W				
R3757	1-216-033-00	METAL GLAZE 220	5% 1/10W				
		<CRYSTAL>		X3701	1-527-722-00	VIBRATOR, CRYSTAL	
				X3702	1-579-583-11	VIBRATOR, CERAMIC	

KV-32XBR48/34XBR48C/35XBR48/35XBR88/37XBR48M

RM-Y144 RM-Y144 RM-Y144 RM-Y144 RM-Y144



REF. NO	PART NO	DESCRIPTION	REMARK	REF. NO.	PART NO.	DESCRIPTION	REMARK
	* A-1195-121-A	PX BOARD, COMPLETE *****		C3393	1-163-133-00	CERAMIC CHIP 470PF	5% 50V
	4-382-854-11	SCREW (M3X10), P, SW (+)		C3394	1-126-959-11	ELECT 0.47MF	20% 50V
		<CAPACITOR>		C3395	1-163-231-11	CERAMIC CHIP 15PF	5% 50V
C3301	1-104-664-11	ELECT 47MF	20% 25V	C3396	1-126-963-11	ELECT 4 7MF	20% 50V
C3302	1-163-809-11	CERAMIC CHIP 0.047MF	10% 25V	C3397	1-126-935-11	ELECT 470MF	20% 16V
C3303	1-163-809-11	CERAMIC CHIP 0.047MF	10% 25V	C3399	1-163-017-00	CERAMIC CHIP 0 0047MF	10% 50V
C3304	1-163-809-11	CERAMIC CHIP 0.047MF	10% 25V	C3400	1-164-346-11	CERAMIC CHIP 1MF	16V
C3306	1-164-232-11	CERAMIC CHIP 0.01MF	10% 50V	C3401	1-163-251-11	CERAMIC CHIP 100PF	5% 50V
C3307	1-126-960-11	ELECT 1MF	20% 50V	C3402	1-164-004-11	CERAMIC CHIP 0.1MF	10% 25V
C3308	1-126-935-11	ELECT 470MF	20% 16V	C3406	1-104-664-11	ELECT 47MF	20% 25V
C3310	1-163-017-00	CERAMIC CHIP 0.0047MF	10% 50V	C3407	1-104-664-11	ELECT 47MF	20% 25V
C3311	1-126-963-11	ELECT 4.7MF	20% 50V	C3408	1-104-664-11	ELECT 47MF	20% 25V
C3312	1-164-004-11	CERAMIC CHIP 0.1MF	10% 25V	C3409	1-164-004-11	CERAMIC CHIP 0 1MF	10% 25V
C3314	1-164-346-11	CERAMIC CHIP 1MF	16V	C3412	1-126-959-11	ELECT 0 47MF	20% 50V
C3315	1-163-251-11	CERAMIC CHIP 100PF	5% 50V	C3413	1-164-232-11	CERAMIC CHIP 0.01MF	10% 50V
C3316	1-163-133-00	CERAMIC CHIP 470PF	5% 50V	C3416	1-126-959-11	ELECT 0.47MF	20% 50V
C3317	1-126-959-11	ELECT 0 47MF	20% 50V	C3417	1-104-664-11	ELECT 47MF	20% 25V
C3318	1-163-231-11	CERAMIC CHIP 15PF	5% 50V	C3418	1-164-232-11	CERAMIC CHIP 0.01MF	10% 50V
C3319	1-163-038-91	CERAMIC CHIP 0.1MF	25V			<FILTER BLOCK>	
C3320	1-163-038-91	CERAMIC CHIP 0.1MF	25V	CM3301	1-473-983-11	FILTER BLOCK, COMB	
C3321	1-107-909-11	ELECT 47MF	20% 16V			<CONNECTOR>	
C3322	1-164-004-11	CERAMIC CHIP 0.1MF	10% 25V	CN3301	1-764-812-11	CONNECTOR, BOARD TO BOARD 11P	
C3323	1-163-038-91	CERAMIC CHIP 0 1MF	25V	CN3302	* 1-764-815-11	CONNECTOR, BOARD TO BOARD 18P	
C3324	1-163-038-91	CERAMIC CHIP 0 1MF	25V			<DIODE>	
C3325	1-163-038-91	CERAMIC CHIP 0.1MF	25V	D3302	8-719-404-49	DIODE MA111	
C3326	1-163-038-91	CERAMIC CHIP 0.1MF	25V	D3303	8-719-404-49	DIODE MA111	
C3327	1-163-133-00	CERAMIC CHIP 470PF	5% 50V	D3313	8-719-404-49	DIODE MA111	
C3329	1-163-038-91	CERAMIC CHIP 0 1MF	25V	D3314	8-719-404-49	DIODE MA111	
C3330	1-164-004-11	CERAMIC CHIP 0.1MF	10% 25V			<FERRITE BEAD>	
C3331	1-164-004-11	CERAMIC CHIP 0.1MF	10% 25V	FB3301	1-414-233-21	INDUCTOR, FERRITE BEAD	
C3332	1-163-038-91	CERAMIC CHIP 0.1MF	25V	FB3302	1-414-233-21	INDUCTOR, FERRITE BEAD	
C3333	1-163-038-91	CERAMIC CHIP 0.1MF	25V	FB3303	1-414-233-21	INDUCTOR, FERRITE BEAD	
C3334	1-164-004-11	CERAMIC CHIP 0 1MF	10% 25V	FB3304	1-414-233-21	INDUCTOR, FERRITE BEAD	
C3335	1-163-038-91	CERAMIC CHIP 0 1MF	25V	FB3305	1-414-233-21	INDUCTOR, FERRITE BEAD	
C3336	1-163-038-91	CERAMIC CHIP 0 1MF	25V	FB3306	1-414-233-21	INDUCTOR, FERRITE BEAD	
C3339	1-163-038-91	CERAMIC CHIP 0 1MF	25V	FB3307	1-414-233-21	INDUCTOR, FERRITE BEAD	
C3340	1-163-133-00	CERAMIC CHIP 470PF	5% 50V	FB3308	1-414-233-21	INDUCTOR, FERRITE BEAD	
C3342	1-163-038-91	CERAMIC CHIP 0.1MF	25V			<IC>	
C3343	1-164-004-11	CERAMIC CHIP 0.1MF	10% 25V	IC3301	8-759-932-69	IC BU4053BCF-T2	
C3344	1-163-038-91	CERAMIC CHIP 0 1MF	25V	IC3302	8-752-078-83	IC CXA2019Q	
C3345	1-164-004-11	CERAMIC CHIP 0.1MF	10% 25V	IC3303	8-759-351-59	IC TC528257J-80(EL)	
C3346	1-164-004-11	CERAMIC CHIP 0 1MF	10% 25V	IC3304	8-759-477-28	IC SAB9076AH	
C3347	1-164-004-11	CERAMIC CHIP 0.1MF	10% 25V	IC3306	8-759-231-53	IC TA7805S	
C3348	1-163-038-91	CERAMIC CHIP 0 1MF	25V	IC3308	8-759-932-69	IC BU4053BCF-T2	
C3349	1-163-038-91	CERAMIC CHIP 0 1MF	25V	IC3309	8-752-078-83	IC CXA2019Q	
C3351	1-163-038-91	CERAMIC CHIP 0.1MF	25V			<COIL>	
C3352	1-163-038-91	CERAMIC CHIP 0.1MF	25V	L3301	1-408-413-00	INDUCTOR 22UH	
C3353	1-163-038-91	CERAMIC CHIP 0.1MF	25V	L3304	1-410-462-11	INDUCTOR 2.2UH	
C3354	1-163-038-91	CERAMIC CHIP 0.1MF	25V	L3305	1-410-462-11	INDUCTOR 2 2UH	
C3355	1-163-038-91	CERAMIC CHIP 0 1MF	25V			<TRANSISTOR>	
C3356	1-164-004-11	CERAMIC CHIP 0.1MF	10% 25V	Q3301	8-729-026-49	TRANSISTOR 2SA1037AK-T146-R	
C3357	1-163-038-91	CERAMIC CHIP 0 1MF	25V	Q3302	8-729-026-49	TRANSISTOR 2SA1037AK-T146-R	
C3358	1-163-038-91	CERAMIC CHIP 0 1MF	25V	Q3303	8-729-026-49	TRANSISTOR 2SA1037AK-T146-R	
C3359	1-163-038-91	CERAMIC CHIP 0.1MF	25V	Q3305	8-729-026-49	TRANSISTOR 2SA1037AK-T146-R	
C3360	1-163-251-11	CERAMIC CHIP 100PF	5% 50V	Q3306	8-729-026-49	TRANSISTOR 2SA1037AK-T146-R	
C3364	1-164-004-11	CERAMIC CHIP 0.1MF	10% 25V				
C3365	1-104-664-11	ELECT 47MF	20% 25V				
C3366	1-164-004-11	CERAMIC CHIP 0 1MF	10% 25V				
C3367	1-104-664-11	ELECT 47MF	20% 25V				
C3386	1-104-664-11	ELECT 47MF	20% 25V				
C3387	1-163-809-11	CERAMIC CHIP 0 047MF	10% 25V				
C3388	1-163-809-11	CERAMIC CHIP 0.047MF	10% 25V				
C3389	1-163-809-11	CERAMIC CHIP 0.047MF	10% 25V				
C3391	1-164-232-11	CERAMIC CHIP 0.01MF	10% 50V				
C3392	1-126-960-11	ELECT 1MF	20% 50V				



REF. NO.	PART NO	DESCRIPTION	REMARK	REF. NO.	PART NO	DESCRIPTION	REMARK
Q3307	8-729-026-49	TRANSISTOR 2SA1037AK-T146-R		R3356	1-216-025-91	METAL GLAZE 100	5% 1/10W
Q3308	8-729-422-27	TRANSISTOR 2SD601A-Q		R3357	1-216-033-00	METAL GLAZE 220	5% 1/10W
Q3309	8-729-422-27	TRANSISTOR 2SD601A-Q		R3358	1-216-001-00	METAL GLAZE 10	5% 1/10W
Q3310	8-729-422-27	TRANSISTOR 2SD601A-Q		R3359	1-216-057-00	METAL GLAZE 2 2K	5% 1/10W
Q3311	8-729-422-27	TRANSISTOR 2SD601A-Q					
Q3318	8-729-026-49	TRANSISTOR 2SA1037AK-T146-R		R3361	1-216-049-91	METAL GLAZE 1K	5% 1/10W
Q3319	8-729-026-49	TRANSISTOR 2SA1037AK-T146-R		R3362	1-216-295-91	CONDUCTOR, CHIP	
Q3320	8-729-026-49	TRANSISTOR 2SA1037AK-T146-R		R3363	1-216-065-00	METAL GLAZE 4 7K	5% 1/10W
Q3325	8-729-026-49	TRANSISTOR 2SA1037AK-T146-R		R3364	1-216-065-00	METAL GLAZE 4 7K	5% 1/10W
Q3326	8-729-026-49	TRANSISTOR 2SA1037AK-T146-R		R3365	1-216-049-91	METAL GLAZE 1K	5% 1/10W
Q3327	8-729-026-49	TRANSISTOR 2SA1037AK-T146-R		R3366	1-216-065-00	METAL GLAZE 4 7K	5% 1/10W
Q3330	8-729-026-49	TRANSISTOR 2SA1037AK-T146-R		R3367	1-216-073-00	METAL GLAZE 10K	5% 1/10W
Q3333	8-729-026-49	TRANSISTOR 2SA1037AK-T146-R		R3368	1-216-073-00	METAL GLAZE 10K	5% 1/10W
Q3339	8-729-422-27	TRANSISTOR 2SD601A-Q		R3369	1-216-065-00	METAL GLAZE 4 7K	5% 1/10W
Q3342	8-729-422-27	TRANSISTOR 2SD601A-Q		R3370	1-216-025-91	METAL GLAZE 100	5% 1/10W
Q3343	8-729-026-49	TRANSISTOR 2SA1037AK-T146-R		R3372	1-216-025-91	METAL GLAZE 100	5% 1/10W
Q3344	8-729-422-27	TRANSISTOR 2SD601A-Q		R3375	1-216-049-91	METAL GLAZE 1K	5% 1/10W
Q3345	8-729-422-27	TRANSISTOR 2SD601A-Q		R3379	1-216-308-00	METAL GLAZE 4 7	5% 1/10W
Q3346	8-729-422-27	TRANSISTOR 2SD601A-Q		R3380	1-216-049-91	METAL GLAZE 1K	5% 1/10W
Q3347	8-729-422-27	TRANSISTOR 2SD601A-Q		R3381	1-216-308-00	METAL GLAZE 4 7	5% 1/10W
		<RESISTOR>		R3383	1-216-049-91	METAL GLAZE 1K	5% 1/10W
R3301	1-216-049-91	METAL GLAZE 1K	5% 1/10W	R3384	1-216-049-91	METAL GLAZE 1K	5% 1/10W
R3302	1-216-049-91	METAL GLAZE 1K	5% 1/10W	R3385	1-216-295-91	CONDUCTOR, CHIP	
R3303	1-216-049-91	METAL GLAZE 1K	5% 1/10W	R3386	1-216-295-91	CONDUCTOR, CHIP	
R3304	1-216-295-91	CONDUCTOR, CHIP		R3387	1-216-295-91	CONDUCTOR, CHIP	
R3305	1-216-295-91	CONDUCTOR, CHIP		R3408	1-216-049-91	METAL GLAZE 1K	5% 1/10W
R3306	1-216-295-91	CONDUCTOR, CHIP		R3409	1-216-049-91	METAL GLAZE 1K	5% 1/10W
R3307	1-216-033-00	METAL GLAZE 220	5% 1/10W	R3410	1-216-049-91	METAL GLAZE 1K	5% 1/10W
R3311	1-216-025-91	METAL GLAZE 100	5% 1/10W	R3413	1-216-295-91	CONDUCTOR, CHIP	
R3312	1-216-025-91	METAL GLAZE 100	5% 1/10W	R3414	1-216-295-91	CONDUCTOR, CHIP	
R3313	1-216-025-91	METAL GLAZE 100	5% 1/10W	R3415	1-216-295-91	CONDUCTOR, CHIP	
R3314	1-216-073-00	METAL GLAZE 10K	5% 1/10W	R3419	1-216-033-00	METAL GLAZE 220	5% 1/10W
R3315	1-216-071-00	METAL GLAZE 8 2K	5% 1/10W	R3420	1-216-025-91	METAL GLAZE 100	5% 1/10W
R3316	1-216-077-00	METAL GLAZE 15K	5% 1/10W	R3421	1-216-025-91	METAL GLAZE 100	5% 1/10W
R3317	1-216-053-00	METAL GLAZE 1 5K	5% 1/10W	R3422	1-216-025-91	METAL GLAZE 100	5% 1/10W
R3318	1-216-033-00	METAL GLAZE 220	5% 1/10W	R3423	1-216-071-00	METAL GLAZE 8 2K	5% 1/10W
R3320	1-216-057-00	METAL GLAZE 2 2K	5% 1/10W	R3425	1-216-077-00	METAL GLAZE 15K	5% 1/10W
R3322	1-216-061-00	METAL GLAZE 3 3K	5% 1/10W	R3426	1-216-053-00	METAL GLAZE 1 5K	5% 1/10W
R3323	1-216-065-00	METAL GLAZE 4 7K	5% 1/10W	R3427	1-216-033-00	METAL GLAZE 220	5% 1/10W
R3324	1-216-065-00	METAL GLAZE 4 7K	5% 1/10W	R3430	1-216-057-00	METAL GLAZE 2 2K	5% 1/10W
R3325	1-216-073-00	METAL GLAZE 10K	5% 1/10W	R3431	1-216-061-00	METAL GLAZE 3 3K	5% 1/10W
R3326	1-216-049-91	METAL GLAZE 1K	5% 1/10W	R3434	1-216-295-91	CONDUCTOR, CHIP	
R3327	1-216-025-91	METAL GLAZE 100	5% 1/10W	R3435	1-216-295-91	CONDUCTOR, CHIP	
R3328	1-216-025-91	METAL GLAZE 100	5% 1/10W	R3438	1-216-025-91	METAL GLAZE 100	5% 1/10W
R3329	1-216-025-91	METAL GLAZE 100	5% 1/10W	R3450	1-216-065-00	METAL GLAZE 4 7K	5% 1/10W
R3330	1-216-025-91	METAL GLAZE 100	5% 1/10W	R3451	1-216-073-00	METAL GLAZE 10K	5% 1/10W
R3331	1-216-001-00	METAL GLAZE 10	5% 1/10W	R3452	1-216-049-91	METAL GLAZE 1K	5% 1/10W
R3332	1-216-001-00	METAL GLAZE 10	5% 1/10W	R3453	1-216-025-91	METAL GLAZE 100	5% 1/10W
R3333	1-216-025-91	METAL GLAZE 100	5% 1/10W	R3454	1-216-025-91	METAL GLAZE 100	5% 1/10W
R3334	1-216-009-00	METAL GLAZE 22	5% 1/10W	R3456	1-216-049-91	METAL GLAZE 1K	5% 1/10W
R3335	1-216-009-00	METAL GLAZE 22	5% 1/10W	R3457	1-216-049-91	METAL GLAZE 1K	5% 1/10W
R3336	1-216-009-00	METAL GLAZE 22	5% 1/10W	R3460	1-216-073-00	METAL GLAZE 10K	5% 1/10W
R3339	1-216-025-91	METAL GLAZE 100	5% 1/10W	R3463	1-216-057-00	METAL GLAZE 2 2K	5% 1/10W
R3340	1-216-025-91	METAL GLAZE 100	5% 1/10W	R3466	1-216-295-91	CONDUCTOR, CHIP	
R3341	1-216-025-91	METAL GLAZE 100	5% 1/10W	R3468	1-216-295-91	CONDUCTOR, CHIP	
R3342	1-216-009-00	METAL GLAZE 22	5% 1/10W	R3470	1-216-037-00	METAL GLAZE 330	5% 1/10W
R3343	1-216-009-00	METAL GLAZE 22	5% 1/10W	R3471	1-216-109-00	METAL GLAZE 330K	5% 1/10W
R3344	1-216-009-00	METAL GLAZE 22	5% 1/10W	R3472	1-216-025-91	METAL GLAZE 100	5% 1/10W
R3345	1-216-025-91	METAL GLAZE 100	5% 1/10W	R3473	1-216-295-91	CONDUCTOR, CHIP	
R3347	1-216-001-00	METAL GLAZE 10	5% 1/10W	R3475	1-216-037-00	METAL GLAZE 330	5% 1/10W
R3348	1-216-001-00	METAL GLAZE 10	5% 1/10W	R3476	1-216-025-91	METAL GLAZE 100	5% 1/10W
R3350	1-216-025-91	METAL GLAZE 100	5% 1/10W	R3477	1-216-109-00	METAL GLAZE 330K	5% 1/10W
R3351	1-216-025-91	METAL GLAZE 100	5% 1/10W	R3479	1-216-295-91	CONDUCTOR, CHIP	
R3352	1-216-025-91	METAL GLAZE 100	5% 1/10W	R3480	1-216-295-91	CONDUCTOR, CHIP	
R3353	1-216-001-00	METAL GLAZE 10	5% 1/10W	R3481	1-216-295-91	CONDUCTOR, CHIP	
R3354	1-216-033-00	METAL GLAZE 220	5% 1/10W	R3484	1-216-295-91	CONDUCTOR, CHIP	
R3355	1-216-033-00	METAL GLAZE 220	5% 1/10W	R3485	1-216-295-91	CONDUCTOR, CHIP	
				R3487	1-216-295-91	CONDUCTOR, CHIP	
				R3488	1-216-295-91	CONDUCTOR, CHIP	

KV-32XBR48/34XBR48C/35XBR48/35XBR88/37XBR48M

RM-Y144 RM-Y144 RM-Y144 RM-Y144 RM-Y144



Les composants identifiés par une trame et une marque Δ sont critiques pour la sécurité. Ne les remplacer que par une pièce portant le numéro spécifié.

The components identified by shading and mark Δ are critical for safety. Replace only with part number specified.

REF. NO	PART NO	DESCRIPTION	REMARK
<CRYSTAL>			
X3301	1-579-583-11	VIBRATOR, CERAMIC	
X3302	1-567-505-11	OSCILLATOR, CRYSTAL	
X3303	1-579-583-11	VIBRATOR, CERAMIC	
X3304	1-567-505-11	OSCILLATOR, CRYSTAL	

	* A-1298-139-A	AX BOARD, COMPLETE	*****
<CAPACITOR>			
C101	1-126-960-11	ELECT 1MF 20%	50V
C102	1-164-161-11	CERAMIC CHIP 0.0022MF 10%	50V
C104	1-126-964-11	ELECT 10MF 20%	50V
C106	1-104-664-11	ELECT 47MF 20%	25V
C108	1-126-942-61	ELECT 1000MF 20%	25V
C109	1-163-259-91	CERAMIC CHIP 220PF 5%	50V
C110	1-163-809-11	CERAMIC CHIP 0.047MF 10%	25V
C111	1-126-960-11	ELECT 1MF 20%	50V
C113	1-104-666-11	ELECT 220MF 20%	25V
C115	1-126-960-11	ELECT 1MF 20%	50V
C1904	1-102-129-00	CERAMIC 0.01MF 10%	50V
C1905	1-126-964-11	ELECT 10MF 20%	50V
C1906	1-102-129-00	CERAMIC 0.01MF 10%	50V
C1907	1-126-964-11	ELECT 10MF 20%	50V
C1908	1-163-009-11	CERAMIC CHIP 0.001MF 10%	50V
<CONNECTOR>			
CN101	1-573-301-21	CONNECTOR, BOARD TO BOARD 20P	
CN102	1-573-979-21	CONNECTOR, BOARD TO BOARD 11P	
CN103	* 1-564-507-11	PLUG, CONNECTOR 4P	
<DIODE>			
D101	8-719-109-90	DIODE RD5.6ESB3	
D103	8-719-911-19	DIODE 1SS119-25	
D104	8-719-911-19	DIODE 1SS119-25	
D105	8-719-911-19	DIODE 1SS119-25	
D106	8-719-911-19	DIODE 1SS119-25	
D107	8-719-911-19	DIODE 1SS119-25	
<IC>			
IC1901	8-752-058-68	IC CXA1315M	
IC1902	8-759-470-63	IC NJM2145M-TE2	
<CHIP CONDUCTOR>			
JR1901	1-216-295-91	CONDUCTOR, CHIP	
<COIL>			
L102	1-410-470-11	INDUCTOR 10UH	
L105	1-410-482-31	INDUCTOR 100UH	
<TRANSISTOR>			
Q101	8-729-119-78	TRANSISTOR 2SC2785-HFE	
Q103	8-729-026-49	TRANSISTOR 2SA1037AK-T146-R	
Q104	8-729-026-49	TRANSISTOR 2SA1037AK-T146-R	
Q105	8-729-026-49	TRANSISTOR 2SA1037AK-T146-R	
Q106	8-729-422-27	TRANSISTOR 2SD601A-Q	
Q1902	8-729-026-49	TRANSISTOR 2SA1037AK-T146-R	
Q1903	8-729-026-49	TRANSISTOR 2SA1037AK-T146-R	
Q1918	8-729-026-49	TRANSISTOR 2SA1037AK-T146-R	

REF. NO	PART NO	DESCRIPTION	REMARK
<RESISTOR>			
R101	1-216-065-00	METAL GLAZE 4.7K	5% 1/10W
R102	1-216-083-00	METAL GLAZE 27K	5% 1/10W
R103	1-216-689-11	METAL GLAZE 39K	5% 1/10W
R104	1-216-049-91	METAL GLAZE 1K	5% 1/10W
R106	1-216-081-00	METAL GLAZE 22K	5% 1/10W
R107	1-216-081-00	METAL GLAZE 22K	5% 1/10W
R108	1-216-081-00	METAL GLAZE 22K	5% 1/10W
R109	1-216-081-00	METAL GLAZE 22K	5% 1/10W
R112	1-249-421-11	CARBON 2.2K	5% 1/4W
R113	1-216-097-91	METAL GLAZE 100K	5% 1/10W
R114	1-216-121-91	METAL GLAZE 1M	5% 1/10W
R115	1-216-073-00	METAL GLAZE 10K	5% 1/10W
R116	1-216-073-00	METAL GLAZE 10K	5% 1/10W
R117	1-216-065-00	METAL GLAZE 4.7K	5% 1/10W
R1905	1-216-073-00	METAL GLAZE 10K	5% 1/10W
R1906	1-216-073-00	METAL GLAZE 10K	5% 1/10W
R1920	1-216-073-00	METAL GLAZE 10K	5% 1/10W
R2904	1-216-033-00	METAL GLAZE 220	5% 1/10W
R2905	1-216-033-00	METAL GLAZE 220	5% 1/10W
R2909	1-216-073-00	METAL GLAZE 10K	5% 1/10W
R2910	1-216-073-00	METAL GLAZE 10K	5% 1/10W
R2912	1-216-065-00	METAL GLAZE 4.7K	5% 1/10W
R2913	1-216-073-00	METAL GLAZE 10K	5% 1/10W
R2914	1-216-073-00	METAL GLAZE 10K	5% 1/10W
R2915	1-216-073-00	METAL GLAZE 10K	5% 1/10W
<TUNER>			
TU101	8-598-339-20	TUNER, FSS BTE LA402	

	* A-1298-140-A	A BOARD, COMPLE	*****
(KV-35XBR48/35XBR88/37XBR48M)			
	* A-1298-141-A	A BOARD, COMPLE	*****
(KV-32XBR48/34XBR48C)			
	4-382-854-11	SCREW (M3X10), P, SW (+)	
<CAPACITOR>			
C001	1-163-259-91	CERAMIC CHIP 220PF	5% 50V
C003	1-163-809-11	CERAMIC CHIP 0.047MF	10% 25V
C005	1-126-960-11	ELECT 1MF	20% 50V
C009	1-104-664-11	ELECT 47MF	20% 25V
C010	1-163-037-11	CERAMIC CHIP 0.022MF	10% 50V
C012	1-163-010-11	CERAMIC CHIP 0.0012MF	10% 50V
C013	1-163-038-91	CERAMIC CHIP 0 1MF	25V
C014	1-163-017-00	CERAMIC CHIP 0 0047MF	10% 50V
C023	1-163-259-91	CERAMIC CHIP 220PF	5% 50V
C028	1-163-227-11	CERAMIC CHIP 10PF	0 5PF 50V
C029	1-163-227-11	CERAMIC CHIP 10PF	0.5PF 50V
C030	1-163-009-11	CERAMIC CHIP 0 001MF	10% 50V
C035	1-163-237-11	CERAMIC CHIP 27PF	5% 50V
C036	1-163-231-11	CERAMIC CHIP 15PF	5% 50V
C037	1-163-243-11	CERAMIC CHIP 47PF	5% 50V
C038	1-163-243-11	CERAMIC CHIP 47PF	5% 50V
C039	1-163-243-11	CERAMIC CHIP 47PF	5% 50V
C040	1-163-243-11	CERAMIC CHIP 47PF	5% 50V
C051	1-164-161-11	CERAMIC CHIP 0 0022MF	10% 50V
C053	1-164-232-11	CERAMIC CHIP 0 01MF	10% 50V
C056	1-163-243-11	CERAMIC CHIP 47PF	5% 50V
C061	1-163-037-11	CERAMIC CHIP 0 022MF	10% 50V
C062	1-163-037-11	CERAMIC CHIP 0.022MF	10% 50V
C063	1-126-941-11	ELECT 470MF	20% 25V

KV-32XBR48/34XBR48C/35XBR48/35XBR88/37XBR48M

RM-Y144

RM-Y144

RM-Y144

RM-Y144

RM-Y144

The components identified by shading and mark Δ are critical for safety. Replace only with part number specified.

Les composants identifiés par une trame et une marque Δ sont critiques pour la sécurité. Ne les remplacer que par une pièce portant le numéro spécifié.



REF. NO.	PART NO.	DESCRIPTION	REMARK	REF NO	PART NO	DESCRIPTION	REMARK
C071	1-164-096-11	CERAMIC 0.01MF	50V	C515	1-106-343-00	MYLAR 0 001MF 10%	100V
C072	1-164-161-11	CERAMIC CHIP 0 0022MF	10% 50V	C516	1-136-113-00	CAPACITOR 0	0 0
C075	1-107-823-11	CERAMIC CHIP 0.47MF	10% 16V	C517	1-107-649-11	ELECT 2 2MF	20% 250V
C351	1-164-232-11	CERAMIC CHIP 0 01MF	10% 50V	C518	1-106-395-00	MYLAR 0 15MF	10% 200V
C352	1-164-004-11	CERAMIC CHIP 0.1MF	10% 25V	C519	1-162-815-11	CERAMIC 47PF	5% 500V
C353	1-163-231-11	CERAMIC CHIP 15PF	5% 50V	C520	1-164-646-11	CERAMIC 2200PF	10% 500V
C354	1-163-133-00	CERAMIC CHIP 470PF	5% 50V	C521	1-164-182-11	CERAMIC CHIP 0 0033MF	10% 50V
C355	1-126-959-11	ELECT 0 47MF	20% 50V	C522	1-126-960-11	ELECT 1MF	20% 50V
C356	1-126-963-11	ELECT 4 7MF	20% 50V	C525	1-102-244-00	CERAMIC 220PF	10% 500V
C357	1-126-959-11	ELECT 0 47MF	20% 50V	C526	1-107-662-11	ELECT 22MF	20% 250V
C358	1-164-232-11	CERAMIC CHIP 0 01MF	10% 50V	C527	1-162-116-00	CERAMIC 680PF	10% 2KV
C359	1-104-665-11	ELECT 100MF	20% 25V	C528	1-164-161-11	CERAMIC CHIP 0 0022MF	10% 50V
C360	1-126-959-11	ELECT 0 47MF	20% 50V	C529	1-128-551-11	ELECT 22MF	20% 25V
C361	1-126-959-11	ELECT 0 47MF	20% 50V	C530	1-137-366-11	FILM 0 0022MF	5% 50V
C362	1-126-959-11	ELECT 0 47MF	20% 50V	C531	1-126-965-11	ELECT 22MF	20% 50V
C363	1-164-232-11	CERAMIC CHIP 0 01MF	10% 50V	C532	1-126-965-11	ELECT 22MF	20% 50V
C364	1-164-232-11	CERAMIC CHIP 0 01MF	10% 50V	C535	1-163-037-11	CERAMIC CHIP 0 022MF	10% 50V
C365	1-164-232-11	CERAMIC CHIP 0 01MF	10% 50V	C537	1-126-941-11	ELECT 470MF	20% 25V
C366	1-137-399-11	FILM 0 1MF	5% 50V	C539	1-126-941-11	ELECT 470MF	20% 25V
C367	1-137-399-11	FILM 0 1MF	5% 50V	C540	1-104-710-11	ELECT 22MF	0 160V
C368	1-137-399-11	FILM 0 1MF	5% 50V	C541	1-128-560-11	ELECT 22MF	20% 100V
C369	1-163-243-11	CERAMIC CHIP 47PF	5% 50V	C542	1-106-383-00	MYLAR 0 047MF	10% 200V
C370	1-163-809-11	CERAMIC CHIP 0 047MF	10% 25V	C545	1-106-387-00	MYLAR 0 068MF	10% 200V
C371	1-163-009-11	CERAMIC CHIP 0.001MF	10% 50V	C546	1-106-343-00	MYLAR 0 001MF	10% 100V
C372	1-126-959-11	ELECT 0 47MF	20% 50V	C547	1-106-343-00	MYLAR 0 001MF	10% 100V
C373	1-126-960-11	ELECT 1MF	20% 50V	C548	1-164-004-11	CERAMIC CHIP 0 1MF	10% 25V
C374	1-164-004-11	CERAMIC CHIP 0 1MF	10% 25V	C549	1-106-375-12	MYLAR 0 022MF	200V
C375	1-164-004-11	CERAMIC CHIP 0 1MF	10% 25V	C561	1-126-967-11	ELECT 47MF	20% 50V
C376	1-126-964-11	ELECT 10MF	20% 50V	C563	1-104-666-11	ELECT 220MF	20% 25V
C377	1-137-399-11	FILM 0 1MF	5% 50V	C564	1-126-960-11	ELECT 1MF	20% 50V
C378	1-136-244-11	FILM 0 1MF	5% 50V	C565	1-126-969-11	ELECT 220MF	20% 50V
C379	1-164-232-11	CERAMIC CHIP 0 01MF	10% 50V	C566	1-126-964-11	ELECT 10MF	20% 50V
C380	1-126-942-61	ELECT 1000MF	20% 25V	C568	1-136-169-00	FILM 0 22MF	5% 50V
C381	1-163-133-00	CERAMIC CHIP 470PF	5% 50V	C571	1-126-941-11	ELECT 470MF	20% 25V
C382	1-164-004-11	CERAMIC CHIP 0 1MF	10% 25V	C1002	1-126-964-11	ELECT 10MF	20% 50V
C383	1-137-399-11	FILM 0 1MF	5% 50V	C1003	1-126-960-11	ELECT 1MF	20% 50V
C384	1-164-004-11	CERAMIC CHIP 0 1MF	10% 25V	C1004	1-126-960-11	ELECT 1MF	20% 50V
C385	1-164-182-11	CERAMIC CHIP 0 0033MF	10% 50V	C1101	1-126-943-11	ELECT 2200MF	20% 25V
C386	1-164-232-11	CERAMIC CHIP 0 01MF	10% 50V	C1103	1-126-965-11	ELECT 22MF	20% 50V
C387	1-126-961-11	ELECT 2 2MF	20% 50V	C1104	1-104-664-11	ELECT 47MF	20% 25V
C388	1-126-959-11	ELECT 0 47MF	20% 50V	C1105	1-104-664-11	ELECT 47MF	20% 25V
C390	1-126-960-11	ELECT 1MF	20% 50V	C1106	1-126-964-11	ELECT 10MF	20% 50V
C391	1-163-017-00	CERAMIC CHIP 0 0047MF	10% 50V	C1107	1-163-037-11	CERAMIC CHIP 0 022MF	10% 50V
C392	1-163-251-11	CERAMIC CHIP 100PF	5% 50V	C1108	1-128-551-11	ELECT 22MF	20% 25V
C393	1-164-004-11	CERAMIC CHIP 0 1MF	10% 25V	C1109	1-126-964-11	ELECT 10MF	20% 50V
C394	1-164-004-11	CERAMIC CHIP 0 1MF	10% 25V	C1110	1-163-227-11	CERAMIC CHIP 10PF	0 5PF 50V
C395	1-104-664-11	ELECT 47MF	20% 25V	C1111	1-163-227-11	CERAMIC CHIP 10PF	0 5PF 50V
C397	1-104-664-11	ELECT 47MF	20% 25V	C1112	1-163-227-11	CERAMIC CHIP 10PF	0 5PF 50V
C398	1-126-961-11	ELECT 2 2MF	20% 50V	C1117	1-126-960-11	ELECT 1MF	20% 50V
C399	1-163-133-00	CERAMIC CHIP 470PF	5% 50V	C1118	1-126-960-11	ELECT 1MF	20% 50V
C501	1-102-110-00	CERAMIC 220PF	10% 50V	C1351	1-163-251-11	CERAMIC CHIP 100PF	5% 50V
C502	1-126-959-11	ELECT 0 47MF	20% 50V	C1353	1-163-037-11	CERAMIC CHIP 0 022MF	10% 50V
C503	1-163-133-00	CERAMIC CHIP 470PF	5% 50V	C1355	1-163-009-11	CERAMIC CHIP 0 001MF	10% 50V
C504	1-102-228-00	CERAMIC 470PF	10% 500V	C1356	1-126-964-11	ELECT 10MF	20% 50V
C505	1-102-228-00	CERAMIC 470PF	10% 500V	C1357	1-107-823-11	CERAMIC CHIP 0 47MF	10% 16V
C506	1-106-383-00	MYLAR 0 047MF	10% 200V	C1358	1-104-665-11	ELECT 100MF	20% 25V
C507	1-162-116-31	CERAMIC 680PF	10% 2KV	C1359	1-164-004-11	CERAMIC CHIP 0 1MF	10% 25V
C508	1-102-244-00	CERAMIC 220PF	10% 500V	C1360	1-164-232-11	CERAMIC CHIP 0 01MF	10% 50V
C509	1-162-116-00	CERAMIC 680PF	10% 2KV	C1361	1-163-241-11	CERAMIC CHIP 39PF	5% 50V
C510	1-137-150-11	MYLAR 0 01MF	10% 100V	C1362	1-163-017-00	CERAMIC CHIP 0 0047MF	10% 50V
C511	1-117-652-21	FILM 22000PF	3% 1.2KV	C1363	1-164-232-11	CERAMIC CHIP 0 01MF	10% 50V
C513	1-136-334-51	FILM 0.033MF	5% 630V	C1367	1-104-664-11	ELECT 47MF	20% 25V
C513	1-130-895-51	FILM 0.056MF	5% 400V	C1368	1-126-960-11	ELECT 1MF	20% 50V
C514	1-117-891-21	FILM 0.62MF	5% 200V	C1369	1-164-004-11	CERAMIC CHIP 0 1MF	10% 25V
C514	1-117-670-21	FILM 0.82MF	5% 200V	C1370	1-126-964-11	ELECT 10MF	20% 50V
				C1371	1-163-017-00	CERAMIC CHIP 0 0047MF	10% 50V
				C1372	1-163-017-00	CERAMIC CHIP 0 0047MF	10% 50V
				C1373	1-163-133-00	CERAMIC CHIP 470PF	5% 50V

KV-32XBR48/34XBR48C/35XBR48/35XBR88/37XBR48M

RM-Y144

RM-Y144

RM-Y144

RM-Y144

RM-Y144



Les composants identifiés par une trame et une marque Δ sont critiques pour la sécurité. Ne les remplacer que par une pièce portant le numéro spécifié.

The components identified by shading and mark Δ are critical for safety. Replace only with part number specified.

REF NO	PART NO	DESCRIPTION	REMARK	REF NO	PART NO	DESCRIPTION	REMARK
C1501	1-117-660-21	FILM	0 12MF 5% 200V (KV-32XBR48/34XBR48C)	D1304	8-719-911-19	DIODE 1SS119-25	
C1691	1-104-665-11	ELECT	100MF 20% 25V	D1305	8-719-911-19	DIODE 1SS119-25	
C1692	1-104-665-11	ELECT	100MF 20% 25V	D1306	8-719-404-49	DIODE MA111	
		<CONNECTOR>		D1641	8-719-979-50	DIODE EGP30D	
CN270	1-573-298-11	CONNECTOR, BOARD TO BOARD 20P		D1642	8-719-979-50	DIODE EGP30D	
CN271	* 1-691-915-11	CONNECTOR, BOARD TO BOARD 15P		D1691	8-719-923-83	DIODE MTZJ-T-77-13A	
CN351	* 1-564-509-11	PLUG, CONNECTOR 6P				<DELAY LINE>	
CN461	* 1-564-508-11	PLUG, CONNECTOR 5P		DL351	1-416-231-11	DELAY LINE	
CN501	* 1-580-798-11	CONNECTOR PIN (DY) 6P				<FERRITE BEAD>	
CN503	* 1-564-508-11	PLUG, CONNECTOR 5P		FB501	1-410-397-21	FERRITE BEAD INDUCTOR 1 IUH	
CN1001	* 1-564-510-11	PLUG, CONNECTOR 7P		FB502	1-410-397-21	FERRITE BEAD INDUCTOR 1.IUH	
CN1101	1-573-298-11	CONNECTOR, BOARD TO BOARD 20P		FB503	1-410-397-21	FERRITE BEAD INDUCTOR 1.IUH	
CN1103	1-573-979-21	CONNECTOR, BOARD TO BOARD 11P				<IC>	
CN1231	* 1-564-512-11	PLUG, CONNECTOR 9P		IC001	8-752-886-53	IC CXP85856A-001S	
CN1641	1-564-513-11	PLUG, CONNECTOR 10P		IC002	8-759-518-23	IC X24C04S8	
CN1642	* 1-564-507-11	PLUG, CONNECTOR 4P		IC351	8-752-076-76	IC CXA2025AS	
CN1643	* 1-508-784-00	PIN, CONNECTOR (5mm PITCH) 1P		IC352	8-752-080-75	IC CXA2039M-T6	
CN1941	* 1-564-511-11	PLUG, CONNECTOR 8P		IC353	8-759-462-91	IC TA1226N	
CN3001	1-573-297-21	CONNECTOR, BOARD TO BOARD 18P		IC501	8-759-700-07	IC NJM2903M	
CN3002	1-573-978-21	CONNECTOR, BOARD TO BOARD 11P		IC561	8-759-980-58	IC TDA8172	
		<DIODE>		IC1001	8-752-058-68	IC CXA1315M	
D001	8-719-911-19	DIODE 1SS119-25				<CHIP CONDUCTOR>	
D002	8-719-109-90	DIODE RD5.6ESB3		JR001	1-216-295-91	CONDUCTOR, CHIP	
D003	8-719-911-19	DIODE 1SS119-25		JR052	1-216-295-91	CONDUCTOR, CHIP	
D004	8-719-110-17	DIODE RD10ESB2		JR053	1-216-295-91	CONDUCTOR, CHIP	
D011	8-719-109-72	DIODE RD3 9ESB2		JR054	1-216-295-91	CONDUCTOR, CHIP	
D012	8-719-911-19	DIODE 1SS119-25		JR4120	1-216-295-91	CONDUCTOR, CHIP	
D013	8-719-911-19	DIODE 1SS119-25				<COIL>	
D014	8-719-911-19	DIODE 1SS119-25		L001	1-410-482-31	INDUCTOR 100UH	
D015	8-719-911-19	DIODE 1SS119-25		L002	1-410-482-31	INDUCTOR 100UH	
D353	8-719-911-19	DIODE 1SS119-25		L003	1-410-470-11	INDUCTOR 10UH	
D356	8-719-911-19	DIODE 1SS119-25		L004	1-410-470-11	INDUCTOR 10UH	
D360	8-719-110-17	DIODE RD10ESB2		L351	1-410-476-11	INDUCTOR 33UH	
D362	8-719-911-19	DIODE 1SS119-25		L352	1-410-482-31	INDUCTOR 100UH	
D363	8-719-404-49	DIODE MA111		L501	1-409-861-11 COIL HORIZONTAL LINEARITY		
D368	8-719-911-19	DIODE 1SS119-25		L502	1-412-552-11	INDUCTOR 2.2mH	
D501	8-719-109-90	DIODE RD5 6ESB3		L503	1-406-677-11	COIL, CHOKE 10mH	
D502	8-719-945-80	DIODE ERC06-15S		L511	1-406-607-41	COIL, CHOKE 15mH	
D503	8-719-945-80	DIODE ERC06-15S		L517	1-412-552-11	INDUCTOR 2.2mH	
D504	8-719-900-26	DIODE ERD29-08J		L541	1-406-677-11	COIL, CHOKE 10mH	
D505	8-719-908-03	DIODE GP08D		L1101	1-410-482-31	INDUCTOR 100UH	
D506	8-719-908-03	DIODE GP08D		L1102	1-410-470-11	INDUCTOR 10UH	
D507	8-719-911-19	DIODE 1SS119-25		L1351	1-410-470-11	INDUCTOR 10UH	
D515	8-719-302-43	DIODE EL1Z				<TRANSISTOR>	
D516	8-719-911-19	DIODE 1SS119-25		Q001	8-729-026-49	TRANSISTOR 2SA1037AK-T146-R	
D518	8-719-911-19	DIODE 1SS119-25		Q002	8-729-422-27	TRANSISTOR 2SD601A-Q	
D519	8-719-302-44 DIODE EL1Z-V1			Q003	8-729-422-27	TRANSISTOR 2SD601A-Q	
D520	8-719-911-19	DIODE 1SS119-25		Q004	8-729-026-49	TRANSISTOR 2SA1037AK-T146-R	
D521	8-719-921-63	DIODE MTZJ-7 5B		Q005	8-729-422-27	TRANSISTOR 2SD601A-Q	
D522	8-719-911-19	DIODE 1SS119-25		Q010	8-729-422-27	TRANSISTOR 2SD601A-Q	
D530	8-719-979-85	DIODE EGP20G		Q011	8-729-422-27	TRANSISTOR 2SD601A-Q	
D531	8-719-979-85	DIODE EGP20G		Q012	8-729-422-27	TRANSISTOR 2SD601A-Q	
D534	8-719-302-43	DIODE EL1Z		Q013	8-729-422-27	TRANSISTOR 2SD601A-Q	
D536	8-719-109-90	DIODE RD5.6ESB3		Q014	8-729-422-27	TRANSISTOR 2SD601A-Q	
D561	8-719-908-03	DIODE GP08D		Q015	8-729-422-27	TRANSISTOR 2SD601A-Q	
D562	8-719-911-19	DIODE 1SS119-25		Q016	8-729-422-27	TRANSISTOR 2SD601A-Q	
D1001	8-719-404-49	DIODE MA111		Q017	8-729-026-49	TRANSISTOR 2SA1037AK-T146-R	
D1002	8-719-404-49	DIODE MA111		Q304	8-729-026-49	TRANSISTOR 2SA1037AK-T146-R	
D1003	8-719-110-17	DIODE RD10ESB2					
D1004	8-719-110-17	DIODE RD10ESB2					
D1102	8-719-110-76	DIODE RD33ESB1					
D1103	8-719-109-90	DIODE RD5.6ESB3					
D1301	8-719-404-49	DIODE MA111					
D1302	8-719-911-19	DIODE 1SS119-25					

The components identified by shading and mark Δ are critical for safety.
Replace only with part number specified.

Les composants identifiés par une trame et une marque Δ sont critiques pour la sécurité.
Ne les remplacer que par une pièce portant le numéro spécifié.



REF. NO.	PART NO.	DESCRIPTION	REMARK	REF. NO.	PART NO.	DESCRIPTION	REMARK
Q305	8-729-026-49	TRANSISTOR 2SA1037AK-T146-R		R032	1-247-815-91	CARBON 220	5% 1/4W
Q306	8-729-026-49	TRANSISTOR 2SA1037AK-T146-R		R034	1-247-815-91	CARBON 220	5% 1/4W
Q351	8-729-422-27	TRANSISTOR 2SD601A-Q		R035	1-247-815-91	CARBON 220	5% 1/4W
Q354	8-729-422-27	TRANSISTOR 2SD601A-Q		R036	1-216-049-91	METAL GLAZE 1K	5% 1/10W
Q356	8-729-026-49	TRANSISTOR 2SA1037AK-T146-R		R037	1-216-049-91	METAL GLAZE 1K	5% 1/10W
Q357	8-729-422-27	TRANSISTOR 2SD601A-Q		R038	1-216-049-91	METAL GLAZE 1K	5% 1/10W
Q358	8-729-422-27	TRANSISTOR 2SD601A-Q		R039	1-247-807-31	CARBON 100	5% 1/4W
Q359	8-729-026-49	TRANSISTOR 2SA1037AK-T146-R		R040	1-247-815-91	CARBON 220	5% 1/4W
Q360	8-729-422-27	TRANSISTOR 2SD601A-Q		R041	1-216-065-00	METAL GLAZE 4.7K	5% 1/10W
Q361	8-729-422-27	TRANSISTOR 2SD601A-Q		R042	1-216-065-00	METAL GLAZE 4.7K	5% 1/10W
Q362	8-729-422-27	TRANSISTOR 2SD601A-Q		R043	1-216-033-00	METAL GLAZE 220	5% 1/10W
Q363	8-729-026-49	TRANSISTOR 2SA1037AK-T146-R		R044	1-216-049-91	METAL GLAZE 1K	5% 1/10W
Q364	8-729-026-49	TRANSISTOR 2SA1037AK-T146-R		R045	1-247-815-91	CARBON 220	5% 1/4W
Q365	8-729-422-27	TRANSISTOR 2SD601A-Q		R046	1-247-815-91	CARBON 220	5% 1/4W
Q366	8-729-422-27	TRANSISTOR 2SD601A-Q		R047	1-249-417-11	CARBON 1K	5% 1/4W
Q367	8-729-026-49	TRANSISTOR 2SA1037AK-T146-R		R048	1-249-417-11	CARBON 1K	5% 1/4W
Q368	8-729-026-49	TRANSISTOR 2SA1037AK-T146-R		R049	1-249-417-11	CARBON 1K	5% 1/4W
Q369	8-729-422-27	TRANSISTOR 2SD601A-Q		R050	1-247-815-91	CARBON 220	5% 1/4W
Q370	8-729-422-27	TRANSISTOR 2SD601A-Q		R051	1-247-815-91	CARBON 220	5% 1/4W
Q501	8-729-140-50	TRANSISTOR 2SC3209LK		R052	1-216-065-00	METAL GLAZE 4.7K	5% 1/10W
Q502	Δ 8-729-035-75	TRANSISTOR 2SC5148(LBSONY)		R053	1-216-065-00	METAL GLAZE 4.7K	5% 1/10W
Q503	8-729-422-27	TRANSISTOR 2SD601A-Q		R054	1-216-065-00	METAL GLAZE 4.7K	5% 1/10W
Q504	8-729-422-27	TRANSISTOR 2SD601A-Q		R055	1-216-097-91	METAL GLAZE 100K	5% 1/10W
Q511	8-729-422-27	TRANSISTOR 2SD601A-Q		R056	1-216-033-00	METAL GLAZE 220	5% 1/10W
Q512	8-729-809-29	TRANSISTOR 2SC4159-E		R057	1-249-417-11	CARBON 1K	5% 1/4W
Q530	8-729-422-27	TRANSISTOR 2SD601A-Q		R058	1-216-033-00	METAL GLAZE 220	5% 1/10W
Q531	8-729-026-49	TRANSISTOR 2SA1037AK-T146-R		R064	1-247-815-91	CARBON 220	5% 1/4W
Q561	8-729-422-27	TRANSISTOR 2SD601A-Q		R065	1-247-815-91	CARBON 220	5% 1/4W
Q562	8-729-422-27	TRANSISTOR 2SD601A-Q		R066	1-247-815-91	CARBON 220	5% 1/4W
Q563	8-729-105-08	TRANSISTOR 2SA1330-O6		R067	1-249-413-11	CARBON 470	5% 1/4W
Q1001	8-729-422-27	TRANSISTOR 2SD601A-Q		R068	1-247-815-91	CARBON 220	5% 1/4W
Q1102	8-729-119-78	TRANSISTOR 2SC2785-HFE		R069	1-247-815-91	CARBON 220	5% 1/4W
Q1103	8-729-422-27	TRANSISTOR 2SD601A-Q		R070	1-249-421-11	CARBON 2.2K	5% 1/4W
Q1351	8-729-422-27	TRANSISTOR 2SD601A-Q		R071	1-247-815-91	CARBON 220	5% 1/4W
Q1352	8-729-422-27	TRANSISTOR 2SD601A-Q		R072	1-216-033-00	METAL GLAZE 220	5% 1/10W
Q1353	8-729-026-49	TRANSISTOR 2SA1037AK-T146-R		R073	1-216-033-00	METAL GLAZE 220	5% 1/10W
Q1354	8-729-422-27	TRANSISTOR 2SD601A-Q		R074	1-216-033-00	METAL GLAZE 220	5% 1/10W
Q1691	8-729-209-15	TRANSISTOR 2SD2012		R075	1-216-033-00	METAL GLAZE 220	5% 1/10W
Q1692	8-729-026-49	TRANSISTOR 2SA1037AK-T146-R		R076	1-216-033-00	METAL GLAZE 220	5% 1/10W
Q1693	8-729-422-27	TRANSISTOR 2SD601A-Q		R077	1-216-033-00	METAL GLAZE 220	5% 1/10W
		<RESISTOR>		R078	1-249-417-11	CARBON 1K	5% 1/4W
R001	1-216-057-00	METAL GLAZE 2.2K	5% 1/10W	R079	1-216-033-00	METAL GLAZE 220	5% 1/10W
R002	1-216-049-91	METAL GLAZE 1K	5% 1/10W	R080	1-216-065-00	METAL GLAZE 4.7K	5% 1/10W
R003	1-216-097-91	METAL GLAZE 100K	5% 1/10W	R081	1-216-025-91	METAL GLAZE 100	5% 1/10W
R004	1-216-121-91	METAL GLAZE 1M	5% 1/10W	R082	1-216-025-91	METAL GLAZE 100	5% 1/10W
R006	1-247-815-91	CARBON 220	5% 1/4W	R083	1-249-429-11	CARBON 10K	5% 1/4W
R007	1-216-073-00	METAL GLAZE 10K	5% 1/10W	R084	1-216-049-91	METAL GLAZE 1K	5% 1/10W
R008	1-247-815-91	CARBON 220	5% 1/4W	R087	1-247-815-91	CARBON 220	5% 1/4W
R009	1-216-073-00	METAL GLAZE 10K	5% 1/10W	R090	1-216-033-00	METAL GLAZE 220	5% 1/10W
R010	1-216-041-00	METAL GLAZE 470	5% 1/10W	R092	1-249-429-11	CARBON 10K	5% 1/4W
R011	1-216-065-00	METAL GLAZE 4.7K	5% 1/10W	R097	1-216-065-00	METAL GLAZE 4.7K	5% 1/10W
R012	1-216-033-00	METAL GLAZE 220	5% 1/10W	R099	1-216-065-00	METAL GLAZE 4.7K	5% 1/10W
R013	1-216-065-00	METAL GLAZE 4.7K	5% 1/10W	R131	1-216-037-00	METAL GLAZE 330	5% 1/10W
R014	1-216-065-00	METAL GLAZE 4.7K	5% 1/10W	R132	1-216-113-00	METAL GLAZE 470K	5% 1/10W
R015	1-216-073-00	METAL GLAZE 10K	5% 1/10W	R133	1-216-037-00	METAL GLAZE 330	5% 1/10W
R016	1-216-073-00	METAL GLAZE 10K	5% 1/10W	R135	1-216-073-00	METAL GLAZE 10K	5% 1/10W
R019	1-249-425-11	CARBON 4.7K	5% 1/4W	R136	1-216-073-00	METAL GLAZE 10K	5% 1/10W
R020	1-216-065-00	METAL GLAZE 4.7K	5% 1/10W	R137	1-216-049-91	METAL GLAZE 1K	5% 1/10W
R022	1-249-429-11	CARBON 10K	5% 1/4W	R319	1-216-049-91	METAL GLAZE 1K	5% 1/10W
R023	1-216-089-91	METAL GLAZE 47K	5% 1/10W	R320	1-216-049-91	METAL GLAZE 1K	5% 1/10W
R025	1-216-033-00	METAL GLAZE 220	5% 1/10W	R321	1-216-049-91	METAL GLAZE 1K	5% 1/10W
R026	1-216-121-91	METAL GLAZE 1M	5% 1/10W	R328	1-216-295-91	CONDUCTOR, CHIP	
R028	1-249-429-11	CARBON 10K	5% 1/4W	R333	1-216-295-91	CONDUCTOR, CHIP	
R029	1-216-025-91	METAL GLAZE 100	5% 1/10W	R336	1-249-387-11	CARBON 3.3	5% 1/4W F
R030	1-249-425-11	CARBON 4.7K	5% 1/4W	R337	1-216-347-11	METAL OXIDE 0.68	5% 1W F
R031	1-247-815-91	CARBON 220	5% 1/4W	R348	1-249-389-11	CARBON 4.7	5% 1/4W F
				R349	1-216-295-91	CONDUCTOR, CHIP	
				R350	1-216-049-91	METAL GLAZE 1K	5% 1/10W
				R352	1-208-803-11	METAL GLAZE 7.5K	0.50% 1/10W

KV-32XBR48/34XBR48C/35XBR48/35XBR88/37XBR48M

RM-Y144

RM-Y144

RM-Y144

RM-Y144

RM-Y144



• The components identified by in this manual have been carefully factory-selected for each set in order to satisfy regulations regarding X-ray radiation. Should replacement be required, replace only with the value originally used.

Les composants identifiés par une trame et une marque sont critiques pour la sécurité. Ne les remplacer que par une pièce portant le numéro spécifié.

The components identified by shading and mark are critical for safety. Replace only with part number specified.

REF. NO.	PART NO.	DESCRIPTION	REMARK
R353	1-208-788-11	METAL GLAZE 1.8K	0.50% 1/10W
R354	1-216-077-00	METAL GLAZE 15K	5% 1/10W
R355	1-216-033-00	METAL GLAZE 220	5% 1/10W
R356	1-216-033-00	METAL GLAZE 220	5% 1/10W
R358	1-247-815-91	CARBON 220	5% 1/4W
R359	1-247-815-91	CARBON 220	5% 1/4W
R360	1-247-815-91	CARBON 220	5% 1/4W
R361	1-216-025-91	METAL GLAZE 100	5% 1/10W
R362	1-216-025-91	METAL GLAZE 100	5% 1/10W
R363	1-216-025-91	METAL GLAZE 100	5% 1/10W
R364	1-216-101-00	METAL GLAZE 150K	5% 1/10W
R365	1-216-097-91	METAL GLAZE 100K	5% 1/10W
R366	1-216-085-00	METAL GLAZE 33K	5% 1/10W
R367	1-216-097-91	METAL GLAZE 100K	5% 1/10W
R368	1-216-097-91	METAL GLAZE 100K	5% 1/10W
R369	1-216-097-91	METAL GLAZE 100K	5% 1/10W
R370	1-249-417-11	CARBON 1K	5% 1/4W
R371	1-216-053-00	METAL GLAZE 1.5K	5% 1/10W
R372	1-216-113-00	METAL GLAZE 470K	5% 1/10W
R373	1-216-073-00	METAL GLAZE 10K	5% 1/10W
R374	1-216-121-91	METAL GLAZE 1M	5% 1/10W (KV-32XBR48/34XBR48C)
R374	1-216-129-00	METAL GLAZE 2.2M	5% 1/10W (KV-35XBR48/35XBR88/37XBR48M)
R375	1-216-025-91	METAL GLAZE 100	5% 1/10W
R376	1-216-073-00	METAL GLAZE 10K	5% 1/10W
R378	1-216-083-00	METAL GLAZE 27K	5% 1/10W
R379	1-216-033-00	METAL GLAZE 220	5% 1/10W
R380	1-247-815-91	CARBON 220	5% 1/4W
R381	1-247-815-91	CARBON 220	5% 1/4W
R382	1-216-037-00	METAL GLAZE 330	5% 1/10W
R383	1-216-049-91	METAL GLAZE 1K	5% 1/10W
R384	1-216-109-00	METAL GLAZE 330K	5% 1/10W
R385	1-249-421-11	CARBON 2.2K	5% 1/4W
R386	1-216-049-91	METAL GLAZE 1K	5% 1/10W
R387	1-216-049-91	METAL GLAZE 1K	5% 1/10W
R388	1-216-089-91	METAL GLAZE 47K	5% 1/10W
R389	1-216-067-00	METAL GLAZE 5.6K	5% 1/10W
R390	1-216-041-00	METAL GLAZE 470	5% 1/10W
R391	1-208-810-11	METAL GLAZE 15K	0.50% 1/10W
R392	1-216-025-91	METAL GLAZE 100	5% 1/10W
R393	1-216-041-00	METAL GLAZE 470	5% 1/10W
R394	1-216-057-00	METAL GLAZE 2.2K	5% 1/10W
R395	1-216-061-00	METAL GLAZE 3.3K	5% 1/10W
R396	1-249-417-11	CARBON 1K	5% 1/4W
R397	1-247-843-11	CARBON 3.3K	5% 1/4W
R398	1-216-095-00	METAL GLAZE 82K	5% 1/10W
R501	1-216-041-00	METAL GLAZE 470	5% 1/10W
R502	1-216-065-00	METAL GLAZE 4.7K	5% 1/10W
R503	1-249-425-11	CARBON 4.7K	5% 1/4W F
R504	1-215-917-51	METAL OXIDE 1K	5% 3W F
R505	1-247-863-91	CARBON 22K	5% 1/4W
R506	1-215-861-00	METAL OXIDE 47	5% 1W F
R507	1-249-401-11	CARBON 47	5% 1/4W
R508	1-249-425-11	CARBON 4.7K	5% 1/4W
R509	1-260-324-11	CARBON 470	5% 1/2W
R510	1-215-861-51	METAL OXIDE 47	5% 1W F
R511	1-215-885-51	METAL OXIDE 68	5% 2W F (KV-32XBR48/34XBR48C)
R511	1-215-886-51	METAL OXIDE 100	5% 2W F (KV-35XBR48/35XBR88/37XBR48M)
R512	1-215-886-51	METAL OXIDE 100	5% 2W F
R514	1-216-081-00	METAL GLAZE 22K	5% 1/10W
R515	1-216-077-00	METAL GLAZE 15K	5% 1/10W
R516	1-216-057-00	METAL GLAZE 2.2K	5% 1/10W
R517	1-249-417-11	CARBON 1K	5% 1/4W
R518	1-216-073-00	METAL GLAZE 10K	5% 1/10W
R519	1-249-413-11	CARBON 470	5% 1/4W
R521	1-216-081-00	METAL GLAZE 22K	5% 1/10W

REF. NO.	PART NO.	DESCRIPTION	REMARK
R523	1-216-073-00	METAL GLAZE 10K	5% 1/10W
R524	1-249-429-11	CARBON 10K	5% 1/4W
R525	1-216-071-00	METAL GLAZE 8.2K	5% 1/10W
R526	1-215-880-00	METAL OXIDE 10	5% 2W F (KV-35XBR48/35XBR88/37XBR48M)
R527	1-216-097-91	METAL GLAZE 100K	5% 1/10W
R528	1-216-081-00	METAL GLAZE 22K	5% 1/10W
R529	1-208-812-11	METAL GLAZE 18K	0.50% 1/10W (KV-35XBR48/35XBR88/37XBR48M)
R529	1-208-814-11	METAL GLAZE 22K	0.50% 1/10W (KV-32XBR48/34XBR48C)
R530	1-216-073-00	METAL GLAZE 10K	5% 1/10W
R531	1-208-838-11	METAL GLAZE 220K	0.50% 1/10W (KV-35XBR48/35XBR88/37XBR48M)
R532	1-208-760-11	METAL GLAZE 120	0.50% 1/10W
R533	1-215-878-51	METAL OXIDE 33K	5% 1W F (KV-35XBR48/35XBR88/37XBR48M)
R533	1-215-879-51	METAL OXIDE 47K	5% 1W F (KV-32XBR48/34XBR48C)
R534	1-249-429-11	CARBON 10K	5% 1/4W
R535	1-216-101-00	METAL GLAZE 150K	5% 1/10W (KV-32XBR48/34XBR48C)
R535	1-216-103-00	METAL GLAZE 180K	5% 1/10W (KV-35XBR48/35XBR88/37XBR48M)
R536	1-260-288-71	CARBON 0.47	5% 1/2W
R537	1-260-288-71	CARBON 0.47	5% 1/2W
R538	1-247-887-00	CARBON 220K	5% 1/4W
R539	1-216-057-00	METAL GLAZE 2.2K	5% 1/10W
R540	1-216-069-00	METAL GLAZE 6.8K	5% 1/10W
R541	1-249-377-11	CARBON 0.47	5% 1/4W F
R542	1-249-397-11	CARBON 22	5% 1/4W F
R543	1-249-377-11	CARBON 0.47	5% 1/4W F
R544	1-216-113-00	METAL GLAZE 470K	5% 1/10W
R545	1-249-387-11	CARBON 3.3	5% 1/4W F
R546	1-215-452-00	METAL 20K	1% 1/4W (KV-35XBR48/35XBR88/37XBR48M)
R546	1-215-453-00	METAL 22K	1% 1/4W (KV-32XBR48/34XBR48C)
R547	1-215-457-00	METAL 33K	1% 1/4W
R549	1-215-437-00	METAL 4.7K	1% 1/4W
R550	1-249-377-91	CARBON 0.47	5% 1/4W F
R551	1-215-873-51	METAL OXIDE 4.7K	5% 1W F
R553	1-249-377-91	CARBON 0.47	5% 1/4W F
R561	1-216-073-00	METAL GLAZE 10K	5% 1/10W
R563	1-215-349-51	METAL OXIDE 1	5% 1W F
R564	1-249-393-11	CARBON 10	5% 1/4W
R565	1-215-889-51	METAL OXIDE 330	5% 2W F
R566	1-216-069-00	METAL GLAZE 6.8K	5% 1/10W
R567	1-249-385-91	CARBON 2.2	5% 1/4W F
R568	1-216-069-00	METAL GLAZE 6.8K	5% 1/10W
R569	1-216-073-00	METAL GLAZE 10K	5% 1/10W
R570	1-216-097-91	METAL GLAZE 100K	5% 1/10W
R571	1-216-081-00	METAL GLAZE 22K	5% 1/10W
R572	1-216-081-00	METAL GLAZE 22K	5% 1/10W
R573	1-216-097-91	METAL GLAZE 100K	5% 1/10W
R574	1-216-365-51	METAL OXIDE 0.47	5% 2W F
R575	1-216-113-00	METAL GLAZE 470K	5% 1/10W
R576	1-216-073-00	METAL GLAZE 10K	5% 1/10W
R577	1-249-441-11	CARBON 100K	5% 1/4W
R578	1-208-784-11	METAL GLAZE 1.2K	0.50% 1/10W
R579	1-208-842-11	METAL GLAZE 330K	0.50% 1/10W
R580	1-249-441-11	CARBON 100K	5% 1/4W
R1001	1-247-807-31	CARBON 100	5% 1/4W
R1002	1-247-807-31	CARBON 100	5% 1/4W
R1003	1-216-073-00	METAL GLAZE 10K	5% 1/10W
R1004	1-216-067-00	METAL GLAZE 5.6K	5% 1/10W
R1005	1-216-073-00	METAL GLAZE 10K	5% 1/10W
R1006	1-247-807-31	CARBON 100	5% 1/4W

KV-32XBR48/34XBR48C/35XBR48/35XBR88/37XBR48M

RM-Y144

RM-Y144

RM-Y144

RM-Y144

RM-Y144

The components identified by shading and mark Δ are critical for safety. Replace only with part number specified.

Les composants identifiés par une trame et une marque Δ sont critiques pour la sécurité. Ne les remplacer que par une pièce portant le numéro spécifié.



REF. NO.	PART NO	DESCRIPTION	REMARK	REF NO	PART NO	DESCRIPTION	REMARK
R1007	1-247-807-31	CARBON 100	5% 1/4W	R1362	1-216-113-00	METAL GLAZE 470K	5% 1/10W
R1008	1-216-065-00	METAL GLAZE 4 7K	5% 1/10W	R1363	1-216-057-00	METAL GLAZE 2 2K	5% 1/10W
R1009	1-216-073-00	METAL GLAZE 10K	5% 1/10W	R1364	1-216-097-91	METAL GLAZE 100K	5% 1/10W
R1010	1-216-049-91	METAL GLAZE 1K	5% 1/10W	R1365	1-216-089-91	METAL GLAZE 47K	5% 1/10W
R1011	1-249-387-11	CARBON 3 3	5% 1/4W F	R1366	1-216-107-00	METAL GLAZE 270K	5% 1/10W
R1012	1-216-049-91	METAL GLAZE 1K	5% 1/10W	R1369	1-216-093-00	METAL GLAZE 68K	5% 1/10W
R1101	1-216-049-91	METAL GLAZE 1K	5% 1/10W	R1371	1-216-295-91	CONDUCTOR, CHIP	
R1102	1-215-900-11	METAL OXIDE 22K	5% 2W F	R1373	1-216-025-91	METAL GLAZE 100	5% 1/10W
R1103	1-216-049-91	METAL GLAZE 1K	5% 1/10W	R1374	1-216-089-91	METAL GLAZE 47K	5% 1/10W
R1104	1-216-083-00	METAL GLAZE 27K	5% 1/10W	R1385	1-216-049-91	METAL GLAZE 1K	5% 1/10W
R1105	1-216-689-11	METAL GLAZE 39K	5% 1/10W	R1386	1-216-049-91	METAL GLAZE 1K	5% 1/10W
R1106	1-216-049-91	METAL GLAZE 1K	5% 1/10W	R1387	1-249-429-11	CARBON 10K	5% 1/4W
R1107	1-216-065-00	METAL GLAZE 4 7K	5% 1/10W	R1388	1-216-073-00	METAL GLAZE 10K	5% 1/10W
R1108	1-216-073-00	METAL GLAZE 10K	5% 1/10W	R1389	1-216-025-91	METAL GLAZE 100	5% 1/10W
R1109	1-216-017-91	METAL GLAZE 47	5% 1/10W	R1390	1-249-417-11	CARBON 1K	5% 1/4W
R1110	1-216-017-91	METAL GLAZE 47	5% 1/10W	R1391	1-216-091-00	METAL GLAZE 56K	5% 1/10W
R1111	1-216-017-91	METAL GLAZE 47	5% 1/10W	R1392	1-216-081-00	METAL GLAZE 22K	5% 1/10W
R1113	1-249-417-11	CARBON 1K	5% 1/4W	R1393	1-216-049-91	METAL GLAZE 1K	5% 1/10W
R1114	1-249-417-11	CARBON 1K	5% 1/4W	R1394	1-208-785-11	METAL GLAZE 1 3K	0 50% 1/10W
R1115	1-216-041-00	METAL GLAZE 470	5% 1/10W	R1395	1-208-782-11	METAL GLAZE 1K	0 50% 1/10W
R1117	1-249-425-11	CARBON 4 7K	5% 1/4W	R1396	1-216-025-91	METAL GLAZE 100	5% 1/10W
R1118	1-249-425-11	CARBON 4 7K	5% 1/4W	R1397	1-216-025-91	METAL GLAZE 100	5% 1/10W
R1120	1-216-057-00	METAL GLAZE 2 2K	5% 1/10W	R1398	1-216-057-00	METAL GLAZE 2 2K	5% 1/10W
R1121	1-216-037-00	METAL GLAZE 330	5% 1/10W	R1399	1-216-049-91	METAL GLAZE 1K	5% 1/10W
R1122	1-216-113-00	METAL GLAZE 470K	5% 1/10W	R1691	1-216-033-00	METAL GLAZE 220	5% 1/10W
R1123	1-216-037-00	METAL GLAZE 330	5% 1/10W	R1692	1-216-397-11	METAL OXIDE 4 7	5% 3W F
R1125	1-216-057-00	METAL GLAZE 2 2K	5% 1/10W	R1693	1-216-073-00	METAL GLAZE 10K	5% 1/10W
R1126	1-216-037-00	METAL GLAZE 330	5% 1/10W	R1694	1-216-073-00	METAL GLAZE 10K	5% 1/10W
R1127	1-216-113-00	METAL GLAZE 470K	5% 1/10W	R1695	1-216-073-00	METAL GLAZE 10K	5% 1/10W
R1128	1-216-037-00	METAL GLAZE 330	5% 1/10W	R1696	1-216-081-00	METAL GLAZE 22K	5% 1/10W
R1130	1-216-057-00	METAL GLAZE 2 2K	5% 1/10W				
R1301	1-249-401-11	CARBON 47	5% 1/4W			<SWITCH>	
R1302	1-249-401-11	CARBON 47	5% 1/4W	S501	1-572-707-11	SWITCH, LEVER	
R1303	1-216-049-91	METAL GLAZE 1K	5% 1/10W			<TRANSFORMER>	
R1304	1-216-049-91	METAL GLAZE 1K	5% 1/10W	T501	1-437-210-11	TRANSFORMER, HORIZONTAL DRIVE	
R1305	1-216-091-00	METAL GLAZE 56K	5% 1/10W	T502	Δ 1-429-408-11	TRANSFORMER, FERRITE (PMT)	
R1306	1-216-081-00	METAL GLAZE 22K	5% 1/10W			(KV-35XBR48/35XBR88/37XBR48M)	
R1307	1-216-049-91	METAL GLAZE 1K	5% 1/10W	T502	Δ 1-424-545-22	TRANSFORMER, FERRITE (PMT)	
R1308	1-216-049-91	METAL GLAZE 1K	5% 1/10W			(KV-32XBR48/34XBR48C)	
R1309	1-216-051-00	METAL GLAZE 1 2K	5% 1/10W	T503	Δ 1-453-244-11	TRANSFORMER ASSY, FLYBACK	
R1310	1-216-025-91	METAL GLAZE 100	5% 1/10W			(NX-2612//X4C) (KV-32XBR48/34XBR48C)	
R1311	1-216-025-91	METAL GLAZE 100	5% 1/10W	T503	Δ X-4034-797-1	TRANSFORMER ASSY, FLYBACK	
R1312	1-216-057-00	METAL GLAZE 2 2K	5% 1/10W			(NX-3005//TIC) (KV-35XBR48/35XBR88/37XBR48M)	
R1313	1-208-780-11	METAL GLAZE 820	0 50% 1/10W	T504	1-413-059-00	TRANSFORMER, FERRITE (DFT)	
R1314	1-208-782-11	METAL GLAZE 1K	0 50% 1/10W			<TUNER>	
R1315	1-216-025-91	METAL GLAZE 100	5% 1/10W	TU102	Δ 8-598-340-20	TUNER, FSS BTF-WA404	
R1316	1-216-091-00	METAL GLAZE 56K	5% 1/10W			<CRYSTAL>	
R1317	1-216-105-91	METAL GLAZE 220K	5% 1/10W	X001	1-578-774-11	VIBRATOR, CRYSTAL	
R1318	1-216-065-00	METAL GLAZE 4 7K	5% 1/10W	X353	1-567-505-11	OSCILLATOR, CRYSTAL	
R1319	1-260-290-71	CARBON 0 68	5% 1/2W	X354	1-579-583-11	VIBRATOR, CERAMIC	
R1322	1-216-073-00	METAL GLAZE 10K	5% 1/10W				
R1323	1-216-065-00	METAL GLAZE 4.7K	5% 1/10W				
R1326	1-249-417-11	CARBON 1K	5% 1/4W				
R1329	1-216-295-91	CONDUCTOR, CHIP					
R1330	1-216-065-00	METAL GLAZE 4 7K	5% 1/10W				
R1333	1-216-065-00	METAL GLAZE 4 7K	5% 1/10W				
R1337	1-216-049-91	METAL GLAZE 1K	5% 1/10W				
R1351	1-247-815-91	CARBON 220	5% 1/4W				
R1352	1-247-815-91	CARBON 220	5% 1/4W				
R1353	1-247-815-91	CARBON 220	5% 1/4W				
R1354	1-216-033-00	METAL GLAZE 220	5% 1/10W				
R1355	1-216-025-91	METAL GLAZE 100	5% 1/10W				
R1356	1-216-025-91	METAL GLAZE 100	5% 1/10W				
R1357	1-216-025-91	METAL GLAZE 100	5% 1/10W				
R1358	1-216-025-91	METAL GLAZE 100	5% 1/10W				
R1359	1-216-025-91	METAL GLAZE 100	5% 1/10W				
R1360	1-216-049-91	METAL GLAZE 1K	5% 1/10W				
R1361	1-216-049-91	METAL GLAZE 1K	5% 1/10W				

KV-32XBR48/34XBR48C/35XBR48/35XBR88/37XBR48M

RM-Y144

RM-Y144

RM-Y144

RM-Y144

RM-Y144



Les composants identifiés par une trame et une marque Δ sont critiques pour la sécurité. Ne les remplacer que par une pièce portant le numéro spécifique.

The components identified by shading and mark Δ are critical for safety. Replace only with part number specified.

REF. NO.	PART NO.	DESCRIPTION	REMARK
* A-1316-323-A	G BOARD, COMPLE	*****	(KV-35XBR48/35XBR88/37XBR48M)
* A-1316-324-A	G BOARD, COMPLE (KV-32XBR48)	*****	
* A-1316-331-A	G BOARD, COMPLE (KV-34XBR48C)	*****	
4-382-854-11	SCREW (M3X10), P, SW (+)		
<CAPACITOR>			
C601	1-130-711-00	FILM 0.22MF 20% 250V	(KV-35XBR48/35XBR88/37XBR48M)
C602	1-126-964-11	ELECT 10MF 20% 50V	
C603	1-113-907-51	CERAMIC 0.0022MF 20% 250V	
C605	1-136-311-51	FILM 0.47MF 20% 125V	
C606	1-117-894-11	ELECT 560MF 20% 250V	
C607	1-117-894-11	ELECT 560MF 20% 250V	
C608	1-165-127-11	CERAMIC 470PF 10% 500V	
C609	1-136-175-00	FILM 0.68MF 5% 50V	
C610	1-136-175-00	FILM 0.68MF 5% 50V	
C611	1-136-171-00	FILM 0.33MF 5% 50V	
C612	1-136-171-00	FILM 0.33MF 5% 50V	
C613	1-164-646-11	CERAMIC 2200PF 10% 500V	
C615	1-129-722-00	FILM 0.047MF 5% 630V	
C641	1-128-550-11	ELECT 2200MF 20% 50V	
C643	1-107-641-11	ELECT 220MF 20% 160V	(except KV-34XBR48C)
C643	1-123-024-21	ELECT 33MF 160V	(KV-34XBR48C)
C647	1-104-665-11	ELECT 100MF 20% 25V	
C648	1-126-941-11	ELECT 470MF 20% 25V	
C651	1-137-366-11	FILM 0.0022MF 5% 50V	(except KV-34XBR48C)
C651	1-137-370-11	FILM 0.01MF 5% 50V	(KV-34XBR48C)
C652	1-106-343-00	MYLAR 0.001MF 10% 200V	(KV-34XBR48C)
C652	1-106-351-00	MYLAR 0.0022MF 200V	(except KV-34XBR48C)
C653	1-107-636-11	ELECT 10MF 20% 160V	
C654	1-164-625-11	CERAMIC 680PF 10% 500V	
C655	1-164-625-11	CERAMIC 680PF 10% 500V	
C656	1-164-625-11	CERAMIC 680PF 10% 500V	
C657	1-164-625-11	CERAMIC 680PF 10% 500V	
C658	1-126-960-11	ELECT 1MF 20% 50V	
C660	1-126-943-11	ELECT 2200MF 20% 25V	
C661	1-126-941-11	ELECT 470MF 20% 25V	
C690	1-164-645-11	CERAMIC 1000PF 10% 500V	
C691	1-164-645-11	CERAMIC 1000PF 10% 500V	
<CONNECTOR>			
CN601	* 1-573-963-11	PIN, CONNECTOR (PC BOARD) 3P	(KV-35XBR48/35XBR88/37XBR48M)
CN602	* 1-580-844-11	PIN, CONNECTOR (POWER)	
CN603	* 1-573-963-11	PIN, CONNECTOR (PC BOARD) 3P	(KV-35XBR48/35XBR88/37XBR48M)
CN604	* 1-508-765-00	PIN, CONNECTOR (5mm PITCH) 3P	(KV-32XBR48)(KV-34XBR48C)
CN641	1-564-513-11	PLUG, CONNECTOR 10P	
CN642	* 1-564-507-11	PLUG, CONNECTOR 4P	
CN643	* 1-508-784-00	PIN, CONNECTOR (5mm PITCH) 1P	
<DIODE>			
D601	8-719-911-19	DIODE 1SS119-25	
D602	8-719-910-63	DIODE D4SR60L	
D615	8-719-028-45	DIODE D2L20U	
D641	8-719-052-92	DIODE D10SBS4F	

REF. NO.	PART NO.	DESCRIPTION	REMARK
D642	8-719-510-02	DIODE D1NS4	
D643	8-719-028-45	DIODE D2L20U	
D644	8-719-028-45	DIODE D2L20U	
D645	8-719-028-45	DIODE D2L20U	
D646	8-719-510-13	DIODE D10SC4MR	
D647	8-719-510-26	DIODE D1NL20-TA2	
D648	8-719-057-52	DIODE EZ0150AV1	
D649	8-719-510-02	DIODE D1NS4	
D650	8-719-510-02	DIODE D1NS4	
D651	8-719-911-19	DIODE 1SS119-25	
D652	8-719-921-63	DIODE MTZJ-7 5B	
D653	8-719-911-19	DIODE 1SS119-25	
<FUSE>			
F601	Δ 1-532-506-51	FUSE (6.3A/250V) (KV-34XBR48C)	
	1-533-223-11	HOLDER, FUSE, F601	
F601	Δ 1-576-193-11	FUSE (6.3A/125V) (except KV-34XBR48C)	
	1-533-223-11	HOLDER, FUSE, F601	
<FERRITE BEAD>			
FB601	1-410-396-41	FERRITE BEAD INDUCTOR 0.45UH	
FB602	1-410-396-41	FERRITE BEAD INDUCTOR 0.45UH	
FB603	1-410-396-41	FERRITE BEAD INDUCTOR 0.45UH	
FB604	1-410-396-41	FERRITE BEAD INDUCTOR 0.45UH	
FB641	1-410-397-21	FERRITE BEAD INDUCTOR 1 1UH	
FB642	1-410-397-21	FERRITE BEAD INDUCTOR 1.1UH	
FB645	1-410-397-21	FERRITE BEAD INDUCTOR 1 1UH	
FB647	1-410-397-21	FERRITE BEAD INDUCTOR 1 1UH	
<IC>			
IC601	Δ 8-729-041-12	TRANSISTOR MX0841AB-F	
IC641	8-759-198-03	IC PQ09RF21	
IC642	8-759-701-56	IC NJM78M05FA	
IC643	8-749-012-13	IC DM-58	
<COIL>			
L642	1-412-529-11	INDUCTOR 22UH	
L643	1-412-525-31	INDUCTOR 10UH	
L644	1-412-531-31	INDUCTOR 33UH	
<TRANSISTOR>			
Q643	8-729-119-78	TRANSISTOR 2SC2785-HFE	
Q644	8-729-119-78	TRANSISTOR 2SC2785-HFE	
Q645	8-729-026-41	TRANSISTOR 2SA933AS-QRT	
Q651	8-729-119-78	TRANSISTOR 2SC2785-HFE	
Q652	8-729-119-78	TRANSISTOR 2SC2785-HFE	
<RESISTOR>			
R603	Δ 1-219-512-91	RESISTOR (SURGE RESISTANT) 2.2M	(except KV-34XBR48C)
R603	Δ 1-247-289-11	CARBON 3.2M 5% 1W	(34XBR48C)
R607	Δ 1-202-933-61	FUSIBLE 0.1 10% 1/2W F	
R608	1-216-373-11	METAL OXIDE 2.2 5% 2W F	
R611	1-216-373-11	METAL OXIDE 2.2 5% 2W F	
R612	1-220-388-51	METAL OXIDE 68K 5% 1W F	
R613	1-220-388-51	METAL OXIDE 68K 5% 1W F	
R614	1-220-388-51	METAL OXIDE 68K 5% 1W F	
R615	1-220-388-51	METAL OXIDE 68K 5% 1W F	
R622	Δ 1-212-958-61	FUSIBLE 10 5% 1/2W F	
R623	1-202-981-11	WIREWOUND 0.82 5% 20W	(except KV-34XBR48C)
R623	1-220-921-21	WIREWOUND 3.3 5% 20W	(KV-34XBR48C)
R624	1-247-895-91	CARBON 470K 5% 1/4W	

The components identified by shading and mark Δ are critical for safety. Replace only with part number specified.

Les composants identifiés par une trame et une marque Δ sont critiques pour la sécurité. Ne les remplacer que par une pièce portant le numéro spécifié.



REF. NO.	PART NO	DESCRIPTION	REMARK	REF NO	PART NO	DESCRIPTION	REMARK
R625	1-247-895-91	CARBON	470K 5% 1/4W	C1764	1-104-664-11	ELECT	47MF 20% 25V
R641	1-247-843-11	CARBON	3 3K 5% 1/4W	C1765	1-102-508-91	CERAMIC	10PF 0.5PF 50V
R642	1-247-843-11	CARBON	3.3K 5% 1/4W	C1767	1-102-129-00	CERAMIC	0 01MF 10% 50V
R643	1-249-387-11	CARBON	3 3 5% 1/4W F	C1768	1-102-129-00	CERAMIC	0.01MF 10% 50V
R645	Δ 1-249-393-9	CARBON	10 5% 1/4W F	C1769	1-126-960-11	ELECT	1MF 20% 50V
R648	1-247-887-00	CARBON	220K 5% 1/4W	C1770	1-102-157-00	CERAMIC	560PF 10% 500V
R648	1-247-891-00	CARBON	330K 5% 1/4W (except KV-34XBR48C)	C1771	1-126-772-11	ELECT	1MF 20% 250V
R649	1-249-425-11	CARBON	4 7K 5% 1/4W F (except KV-34XBR48C)	C1772	1-102-129-00	CERAMIC	0 01MF 10% 50V
R649	1-249-433-11	CARBON	22K 5% 1/4W F (KV-34XBR48C)	C1773	1-102-157-00	CERAMIC	560PF 10% 500V
R650	1-249-425-11	CARBON	4 7K 5% 1/4W	C1774	1-126-772-11	ELECT	1MF 20% 250V
R653	1-247-863-91	CARBON	22K 5% 1/4W	C1775	1-102-129-00	CERAMIC	0 01MF 10% 50V
R655	1-247-863-91	CARBON	22K 5% 1/4W	C1776	1-102-157-00	CERAMIC	560PF 10% 500V
R656	1-249-429-11	CARBON	10K 5% 1/4W	C1777	1-126-772-11	ELECT	1MF 20% 250V
R657	1-247-863-91	CARBON	22K 5% 1/4W	C1778	1-102-074-00	CERAMIC	0 001MF 10% 50V
R659	1-249-429-11	CARBON	10K 5% 1/4W	C1779	1-162-116-00	CERAMIC	680PF 10% 2KV
R660	Δ 1-249-393-9	CARBON	10 5% 1/4W F	C1783	1-106-375-12	MYLAR	0 022MF 200V
R661	1-249-419-11	CARBON	1 5K 5% 1/4W F	C1784	1-106-375-12	MYLAR	0 022MF 200V
R662	1-249-429-11	CARBON	10K 5% 1/4W	C1786	1-107-651-11	ELECT	4.7MF 20% 250V
R665	1-249-421-11	CARBON	2.2K 5% 1/4W	<CONNECTOR>			
R666	Δ 1-249-377-9	CARBON	0.47 5% 1/4W F	CN1761	* 1-564-509-11	PLUG, CONNECTOR 6P	
R667	Δ 1-249-377-9	CARBON	0.47 5% 1/4W F	CN1764	* 1-564-508-11	PLUG, CONNECTOR 5P	
R668	Δ 1-249-377-9	CARBON	0.47 5% 1/4W F	CN1765	1-695-915-11	TAB (CONTACT)	
R670	Δ 1-249-377-9	CARBON	0.47 5% 1/4W F	CN1766	1-695-915-11	TAB (CONTACT)	
R671	Δ 1-249-377-9	CARBON	0.47 5% 1/4W F	<DIODE>			
R672	Δ 1-249-377-9	CARBON	0.47 5% 1/4W F	D1712	8-719-901-83	DIODE 1SS83	
R678	1-247-843-11	CARBON	3.3K 5% 1/4W	D1713	8-719-908-03	DIODE GP08D	
R679	1-247-863-91	CARBON	22K 5% 1/4W	D1762	8-719-911-19	DIODE 1SS119-25	
R680	1-249-377-11	CARBON	0.47 5% 1/4W F	D1763	8-719-911-19	DIODE 1SS119-25	
R681	Δ 1-202-933-61	FUSIBLE	0.1 10% 1/2W F	D1764	8-719-911-19	DIODE 1SS119-25	
<RELAY>							
RY601	Δ 1-755-146-11	RELAY		D1767	8-719-109-90	DIODE RD5 6ESB3	
<TRANSFORMER>							
T602	Δ 1-426-717-11	TRANSFORMER, LINE FILTER (LFT)		D1768	8-719-911-19	DIODE 1SS119-25	
T603	Δ 1-429-992-11	TRANSFORMER, CONVERTER (PRT)		D1769	8-719-109-71	DIODE RD3 9ESB1	
T605	Δ 1-431-467-11	TRANSFORMER, CONVERTER (PIT)		D1770	8-719-901-83	DIODE 1SS83	
<THERMISTOR>							
THP601	Δ 1-809-539-11	THERMISTOR, POSITIVE (except KV-34XBR48C)		D1771	8-719-901-83	DIODE 1SS83	
THP601	Δ 1-809-527-11	THERMISTOR, POSITIVE (KV-34XBR48C)		<IC>			
<VARISTOR>							
VDR601	1-801-070-41	VARISTOR ERZV10D431		IC1761	8-759-346-42	IC TDA6101Q/N3	
VDR602	Δ 1-801-074-41	VARISTOR ERZV10D271 (except KV-34XBR48C)		IC1762	8-759-346-42	IC TDA6101Q/N3	
VDR602	Δ 1-809-267-41	VARISTOR ERZV10D471 (KV-34XBR48C)		IC1763	8-759-346-42	IC TDA6101Q/N3	

* A-1331-692-A C BOARD, COMPLETE							

(KV-35XBR48/35XBR88/37XBR48M)							
* A-1331-694-A C BOARD, COMPLETE							

(KV-32XBR48/34XBR48C)							
<CAPACITOR>							
C1761	1-102-508-91	CERAMIC	10PF 0.5PF 50V	R1761	1-215-413-00	METAL	470 1% 1/4W
C1762	1-104-664-11	ELECT	47MF 20% 25V	R1762	1-215-413-00	METAL	470 1% 1/4W
C1763	1-102-508-91	CERAMIC	10PF 0.5PF 50V	R1763	1-215-424-00	METAL	1 3K 1% 1/4W
				R1764	1-249-441-11	CARBON	100K 5% 1/4W
				R1765	1-247-863-91	CARBON	22K 5% 1/4W
				R1766	1-215-424-00	METAL	1 3K 1% 1/4W
				R1767	1-249-437-11	CARBON	47K 5% 1/4W
				R1768	1-247-807-31	CARBON	100 5% 1/4W
				R1769	1-249-417-11	CARBON	1K 5% 1/4W
				R1770	1-215-424-00	METAL	1 3K 1% 1/4W

KV-32XBR48/34XBR48C/35XBR48/35XBR88/37XBR48M

RM-Y144 RM-Y144 RM-Y144 RM-Y144 RM-Y144

C **HX** **HF** **WA**

REF NO	PART NO	DESCRIPTION	REMARK
R1771	1-249-432-11	CARBON 18K 5%	1/4W
R1772	1-249-421-11	CARBON 2 2K 5%	1/4W
R1773	1-249-422-11	CARBON 2 7K 5%	1/4W
R1774	1-215-903-11	METAL OXIDE 68K 5%	2W F
R1775	1-249-422-11	CARBON 2 7K 5%	1/4W
R1776	1-215-903-11	METAL OXIDE 68K 5%	2W F
R1777	1-260-099-11	CARBON 1K 5%	1/2W
R1778	1-249-422-11	CARBON 2 7K 5%	1/4W
R1779	1-215-903-11	METAL OXIDE 68K 5%	2W F
R1780	1-249-436-11	CARBON 39K 5%	1/4W
R1781	1-260-099-11	CARBON 1K 5%	1/2W
R1782	1-260-099-11	CARBON 1K 5%	1/2W
R1783	1-260-087-11	CARBON 100 5%	1/2W
R1786	1-260-123-11	CARBON 100K 5%	1/2W
R1787	1-216-365-00	METAL OXIDE 0 47 5%	2W F (KV-35XBR48/35XBR88/37XBR48M)
R1787	1-216-374-00	METAL OXIDE 2 7 5%	2W F (KV-32XBR48/34XBR48C)
R1788	1-260-132-11	CARBON 560K 5%	1/2W

* A-1372-350-A HX BOARD, COMPLETE *****			
<CAPACITOR>			
C2001	1-104-665-11	ELECT 100MF 20%	25V
<CONNECTOR>			
CN2001	* 1-564-522-11	PLUG, CONNECTOR 7P	
<DIODE>			
D2002	8-719-057-09	DIODE LNJ801LPDJA	
D2003	8-719-057-09	DIODE LNJ801LPDJA	
<IC>			
IC2001	8-742-014-10	HYB IC SBX1981-51	
<RESISTOR>			
R2001	1-216-033-00	METAL GLAZE 220 5%	1/10W
R2002	1-216-033-00	METAL GLAZE 220 5%	1/10W
R2003	1-216-017-91	METAL GLAZE 47 5%	1/10W
R2010	1-216-047-91	METAL GLAZE 820 5%	1/10W
R2011	1-216-049-91	METAL GLAZE 1K 5%	1/10W
R2012	1-216-055-00	METAL GLAZE 1.8K 5%	1/10W
R2013	1-216-065-00	METAL GLAZE 4 7K 5%	1/10W
R2014	1-216-073-00	METAL GLAZE 10K 5%	1/10W
<SWITCH>			
S2001	1-572-198-11	SWITCH, KEYBOARD	
S2002	1-572-198-11	SWITCH, KEYBOARD	
S2003	1-572-198-11	SWITCH, KEYBOARD	
S2004	1-572-198-11	SWITCH, KEYBOARD	
S2005	1-572-198-11	SWITCH, KEYBOARD	
S2006	1-572-198-11	SWITCH, KEYBOARD	
S2007	1-572-198-11	SWITCH, KEYBOARD	

REF NO	PART NO	DESCRIPTION	REMARK
* A-1372-351-A HF BOARD, COMPLETE *****			
<CAPACITOR>			
C1234	1-126-960-11	ELECT 1MF 20%	50V
C1235	1-126-960-11	ELECT 1MF 20%	50V
<CONNECTOR>			
CN1232	* 1-564-512-11	PLUG, CONNECTOR 9P	
<DIODE>			
D1233	8-719-110-17	DIODE RD10ESB2	
<JACK>			
J1231	1-565-929-11	TERMINAL BLOCK, S 3P	
<RESISTOR>			
R1233	1-249-425-11	CARBON 4 7K 5%	1/4W
R1235	1-216-065-00	METAL GLAZE 4.7K 5%	1/10W
R1236	1-216-113-00	METAL GLAZE 470K 5%	1/10W
R1237	1-216-065-00	METAL GLAZE 4 7K 5%	1/10W
R1238	1-216-113-00	METAL GLAZE 470K 5%	1/10W

* A-1372-348-A WA BOARD, COMPLETE ***** (KV-35XBR48/35XBR88/37XBR48M)			
* A-1372-352-A WA BOARD, COMPLETE ***** (KV-32XBR48/34XBR48C)			
4-382-854-11 SCREW (M3X10), P, SW (+)			
<CAPACITOR>			
C944	1-164-232-11	CERAMIC CHIP 0 01MF 10%	50V
C946	1-104-665-11	ELECT 100MF 20%	25V
C949	1-161-830-00	CERAMIC 0 0047MF	500V
C950	1-126-941-11	ELECT 470MF 20%	25V
C951	1-107-637-11	ELECT 22MF 20%	160V
C952	1-104-999-11	MYLAR 0 1MF 10%	200V
C953	1-106-383-00	MYLAR 0 047MF 10%	200V
C954	1-137-364-11	FILM 0 001MF 5%	50V
C955	1-107-667-11	ELECT 2 2MF 20%	160V
C956	1-137-364-11	FILM 0 001MF 5%	50V
C957	1-106-383-00	MYLAR 0 047MF 10%	200V
C958	1-126-941-11	ELECT 470MF 20%	25V
C961	1-163-251-11	CERAMIC CHIP 100PF 5%	50V
C962	1-164-232-11	CERAMIC CHIP 0 01MF 10%	50V
C965	1-163-809-11	CERAMIC CHIP 0 047MF 10%	25V
C966	1-163-009-11	CERAMIC CHIP 0 001MF 10%	50V
C967	1-129-718-00	FILM 0 022MF 5%	630V
C968	1-137-579-11	FILM 0 068MF 5%	100V
C969	1-163-035-00	CERAMIC CHIP 0 047MF	50V (KV-35XBR48/35XBR88/37XBR48M)
C981	1-126-941-11	ELECT 470MF 20%	25V
C983	1-137-366-11	FILM 0 0022MF 5%	50V (KV-35XBR48/35XBR88/37XBR48M)
C1941	1-126-941-11	ELECT 470MF 20%	25V
C1948	1-164-161-11	CERAMIC CHIP 0 0022MF 10%	50V



REF. NO.	PART NO.	DESCRIPTION	REMARK	REF. NO.	PART NO.	DESCRIPTION	REMARK
		<CONNECTOR>		R975	1-215-886-11	METAL OXIDE 100 5% 2W F (KV-32XBR48/34XBR48C)	
CN941	* 1-564-511-11	PLUG, CONNECTOR 8P		R976	1-215-859-00	METAL OXIDE 22 5% 1W F	
CN961	* 1-770-723-11	CONNECTOR, BOARD TO BOARD 8P		R977	1-249-401-11	CARBON 47 5% 1/4W F	
CN981	* 1-564-506-11	PLUG, CONNECTOR 3P (KV-35XBR48/35XBR88/37XBR48M)		R978	1-215-885-00	METAL OXIDE 68 5% 2W F (KV-35XBR48/35XBR88/37XBR48M)	
		<DIODE>		R978	1-215-886-11	METAL OXIDE 100 5% 2W F (KV-32XBR48/34XBR48C)	
D941	8-719-911-19	DIODE 1SS119-25		R979	1-216-017-91	METAL GLAZE 47 5% 1/10W	
D946	8-719-110-88	DIODE RD39ESB2		R981	1-216-085-00	METAL GLAZE 33K 5% 1/10W (KV-35XBR48/35XBR88/37XBR48M)	
D947	8-719-110-88	DIODE RD39ESB2		R982	1-216-081-00	METAL GLAZE 22K 5% 1/10W (KV-35XBR48/35XBR88/37XBR48M)	
D962	8-719-911-19	DIODE 1SS119-25		R983	1-216-077-00	METAL GLAZE 15K 5% 1/10W (KV-35XBR48/35XBR88/37XBR48M)	
D964	8-719-302-43	DIODE EL1Z		R984	1-216-069-00	METAL GLAZE 6 8K 5% 1/10W (KV-35XBR48/35XBR88/37XBR48M)	
		<IC>		R987	1-216-049-91	METAL GLAZE 1K 5% 1/10W (KV-35XBR48/35XBR88/37XBR48M)	
IC961	8-759-700-07	IC NJM2903M		R992	1-216-073-00	METAL GLAZE 10K 5% 1/10W (KV-35XBR48/35XBR88/37XBR48M)	
IC981	8-759-603-37	IC M5216P (KV-35XBR48/35XBR88/37XBR48M)		R1941	1-260-312-11	CARBON 47 5% 1/2W	
		<COIL>		R1942	1-249-387-11	CARBON 3 3 5% 1/4W F	
L962	1-406-989-21	COIL, CHOKE 10mH		R1943	1-249-414-11	CARBON 560 5% 1/4W F	
L963	1-406-675-11	COIL, CHOKE 4.7mH		R1944	1-249-432-11	CARBON 18K 5% 1/4W	
		<TRANSISTOR>		R1945	1-215-914-11	METAL OXIDE 330 5% 3W F	
Q943	8-729-422-27	TRANSISTOR 2SD601A-Q		R1946	1-249-417-11	CARBON 1K 5% 1/4W F	
Q944	8-729-422-27	TRANSISTOR 2SD601A-Q		R1947	1-249-432-11	CARBON 18K 5% 1/4W	
Q945	8-729-422-27	TRANSISTOR 2SD601A-Q		R1948	1-249-414-11	CARBON 560 5% 1/4W	
Q946	8-729-017-05	TRANSISTOR 2SA1837		R1949	1-249-387-11	CARBON 3 3 5% 1/4W F	
Q947	8-729-017-06	TRANSISTOR 2SC4793		R1950	1-249-401-11	CARBON 47 5% 1/4W F	
Q962	8-729-931-45	TRANSISTOR IRF614					
Q963	8-729-026-49	TRANSISTOR 2SA1037AK-T146-R					
Q965	8-729-422-27	TRANSISTOR 2SD601A-Q					
Q966	8-729-026-49	TRANSISTOR 2SA1037AK-T146-R					
Q981	8-729-422-27	TRANSISTOR 2SD601A-Q (KV-35XBR48/35XBR88/37XBR48M)					
		<RESISTOR>					
R943	1-216-025-91	METAL GLAZE 100 5% 1/10W					
R948	1-216-049-91	METAL GLAZE 1K 5% 1/10W					
R949	1-216-057-00	METAL GLAZE 2.2K 5% 1/10W					
R950	1-216-049-91	METAL GLAZE 1K 5% 1/10W					
R951	1-216-049-91	METAL GLAZE 1K 5% 1/10W					
R952	1-216-041-00	METAL GLAZE 470 5% 1/10W					
R953	1-216-021-00	METAL GLAZE 68 5% 1/10W					
R954	1-216-033-00	METAL GLAZE 220 5% 1/10W					
R955	1-216-047-91	METAL GLAZE 820 5% 1/10W					
R956	1-216-025-91	METAL GLAZE 100 5% 1/10W					
R957	1-216-073-00	METAL GLAZE 10K 5% 1/10W					
R958	1-216-025-91	METAL GLAZE 100 5% 1/10W					
R959	1-216-021-00	METAL GLAZE 68 5% 1/10W					
R960	1-216-689-11	METAL GLAZE 39K 5% 1/10W					
R961	1-216-049-91	METAL GLAZE 1K 5% 1/10W					
R962	1-216-057-00	METAL GLAZE 2 2K 5% 1/10W					
R963	1-216-097-91	METAL GLAZE 100K 5% 1/10W					
R964	1-216-073-00	METAL GLAZE 10K 5% 1/10W					
R965	1-216-073-00	METAL GLAZE 10K 5% 1/10W					
R966	1-216-097-91	METAL GLAZE 100K 5% 1/10W					
R967	1-216-063-91	METAL GLAZE 3.9K 5% 1/10W					
R968	1-216-085-00	METAL GLAZE 33K 5% 1/10W					
R969	1-216-295-91	CONDUCTOR, CHIP					
R970	1-216-033-00	METAL GLAZE 220 5% 1/10W					
R971	1-247-895-91	CARBON 470K 5% 1/4W					
R972	1-216-073-00	METAL GLAZE 10K 5% 1/10W					
R973	1-216-121-91	METAL GLAZE 1M 5% 1/10W					
R974	1-216-073-00	METAL GLAZE 10K 5% 1/10W					
R975	1-215-885-00	METAL OXIDE 68 5% 2W F (KV-35XBR48/35XBR88/37XBR48M)					
		<CAPACITOR>		C1461	1-126-960-11	ELECT 1MF 20% 50V	
				C1462	1-126-960-11	ELECT 1MF 20% 50V	
				C1463	1-126-961-11	ELECT 2.2MF 20% 50V	
				C1464	1-104-666-11	ELECT 220MF 20% 25V	
				C1465	1-126-960-11	ELECT 1MF 20% 50V	
				C1467	1-104-664-11	ELECT 47MF 20% 25V	
				C1468	1-126-960-11	ELECT 1MF 20% 50V	
				C1470	1-104-666-11	ELECT 220MF 20% 25V	
				C1471	1-136-169-00	FILM 0 22MF 5% 50V	
				C1472	1-136-173-00	FILM 0 47MF 5% 50V	
				C1473	1-128-550-11	ELECT 2200MF 20% 50V	
				C1474	1-136-169-00	FILM 0 22MF 5% 50V	
				C1475	1-128-550-11	ELECT 2200MF 20% 50V	
				C1476	1-128-550-11	ELECT 2200MF 20% 50V	
		<CONNECTOR>					
				CN1461	* 1-564-508-11	PLUG, CONNECTOR 5P	
				CN1462	* 1-564-507-11	PLUG, CONNECTOR 4P	
				CN1463	* 1-564-508-11	PLUG, CONNECTOR 5P	
		<DIODE>					
				D1461	8-719-911-19	DIODE 1SS119-25	
				D1462	8-719-979-50	DIODE EGP30D	
		<IC>					
				IC1461	8-759-089-13	IC TDA7262	

* A-1380-540-A K BOARD, COMPLETE

4-382-854-11 SCREW (M3X10), P, SW (+)

<CAPACITOR>

<CONNECTOR>

<DIODE>

<IC>



Les composants identifiés par une trame et une marque Δ sont critiques pour la sécurité. Ne les remplacer que par une pièce portant le numéro spécifié.

The components identified by shading and mark Δ are critical for safety. Replace only with part number specified.

REF. NO.	PART NO	DESCRIPTION	REMARK
<IC LINK>			
PS1461	532-984-91	LINK, IC (2A/90V)	
<TRANSISTOR>			
Q1461	8-729-422-27	TRANSISTOR 2SD601A-Q	
Q1462	8-729-026-49	TRANSISTOR 2SA1037AK-T146-R	
Q1463	8-729-900-53	TRANSISTOR DTC114EK	
Q1464	8-729-900-53	TRANSISTOR DTC114EK	
<RESISTOR>			
R1461	1-216-065-00	METAL GLAZE 4.7K	5% 1/10W
R1462	1-216-073-00	METAL GLAZE 10K	5% 1/10W
R1464	1-216-065-00	METAL GLAZE 4.7K	5% 1/10W
R1465	1-216-065-00	METAL GLAZE 4.7K	5% 1/10W
R1466	1-216-089-91	METAL GLAZE 47K	5% 1/10W
R1467	1-216-073-00	METAL GLAZE 10K	5% 1/10W
R1469	1-249-385-11	CARBON 2.2	5% 1/4W F
R1470	1-249-385-11	CARBON 2.2	5% 1/4W F
R1471	1-216-089-91	METAL GLAZE 47K	5% 1/10W
R1472	1-216-041-00	METAL GLAZE 470	5% 1/10W
R1473	1-216-113-00	METAL GLAZE 470K	5% 1/10W
R1474	1-216-077-00	METAL GLAZE 15K	5% 1/10W
R1475	1-216-077-00	METAL GLAZE 15K	5% 1/10W
R1476	1-247-791-91	CARBON 22	5% 1/4W
R1477	1-249-419-11	CARBON 1.5K	5% 1/4W F
R1478	1-247-791-91	CARBON 22	5% 1/4W
R1479	1-249-419-11	CARBON 1.5K	5% 1/4W F
R1480	1-249-421-11	CARBON 2.2K	5% 1/4W
R1481	1-249-421-11	CARBON 2.2K	5% 1/4W
R1482	1-216-073-00	METAL GLAZE 10K	5% 1/10W
R1483	1-216-073-00	METAL GLAZE 10K	5% 1/10W

* A-1394-860-A UX BOARD, COMPLETE

REF. NO.	PART NO	DESCRIPTION	REMARK
<CAPACITOR>			
C151	1-126-960-11	ELECT 1MF	20% 50V
C152	1-126-960-11	ELECT 1MF	20% 50V
C153	1-164-222-11	CERAMIC CHIP 0.22MF	25V
C154	1-164-222-11	CERAMIC CHIP 0.22MF	25V
C156	1-163-809-11	CERAMIC CHIP 0.047MF	10% 25V
C158	1-163-017-00	CERAMIC CHIP 0.0047MF	10% 50V
C159	1-163-017-00	CERAMIC CHIP 0.0047MF	10% 50V
C160	1-126-959-11	ELECT 0.47MF	20% 50V
C161	1-126-960-11	ELECT 1MF	20% 50V
C162	1-126-960-11	ELECT 1MF	20% 50V
C164	1-163-038-91	CERAMIC CHIP 0.1MF	25V
C166	1-163-038-91	CERAMIC CHIP 0.1MF	25V
C167	1-104-665-11	ELECT 100MF	20% 25V
C168	1-104-666-11	ELECT 220MF	20% 25V
C173	1-163-017-00	CERAMIC CHIP 0.0047MF	10% 50V
C174	1-164-005-11	CERAMIC CHIP 0.47MF	25V
C201	1-128-551-11	ELECT 22MF	20% 25V
C202	1-128-551-11	ELECT 22MF	20% 25V
C203	1-128-551-11	ELECT 22MF	20% 25V
C204	1-126-960-11	ELECT 1MF	20% 50V
C205	1-126-960-11	ELECT 1MF	20% 50V
C231	1-164-232-11	CERAMIC CHIP 0.01MF	10% 50V
C232	1-128-551-11	ELECT 22MF	20% 25V
C233	1-128-551-11	ELECT 22MF	20% 25V
C234	1-126-960-11	ELECT 1MF	20% 50V
C235	1-126-960-11	ELECT 1MF	20% 50V

REF. NO.	PART NO	DESCRIPTION	REMARK
C236	1-128-551-11	ELECT 22MF	20% 25V
C237	1-126-960-11	ELECT 1MF	20% 50V
C238	1-126-960-11	ELECT 1MF	20% 50V
C241	1-126-941-11	ELECT 470MF	20% 25V
C242	1-126-959-11	ELECT 0.47MF	20% 50V
C243	1-126-959-11	ELECT 0.47MF	20% 50V
C244	1-126-959-11	ELECT 0.47MF	20% 50V
C245	1-126-959-11	ELECT 0.47MF	20% 50V
C247	1-126-941-11	ELECT 470MF	20% 25V
C248	1-126-959-11	ELECT 0.47MF	20% 50V
C249	1-126-959-11	ELECT 0.47MF	20% 50V
C272	1-163-231-11	CERAMIC CHIP 15PF	5% 50V
C273	1-128-551-11	ELECT 22MF	20% 25V
C277	1-128-551-11	ELECT 22MF	20% 25V
C278	1-128-551-11	ELECT 22MF	20% 25V
C279	1-164-232-11	CERAMIC CHIP 0.01MF	10% 50V
C281	1-128-551-11	ELECT 22MF	20% 25V
C283	1-126-941-11	ELECT 470MF	20% 25V
C284	1-126-941-11	ELECT 470MF	20% 25V
C1051	1-126-964-11	ELECT 10MF	20% 50V
C1053	1-104-665-11	ELECT 100MF	20% 25V
C1151	1-164-346-11	CERAMIC CHIP 1MF	16V
C1152	1-163-038-91	CERAMIC CHIP 0.1MF	25V
C1153	1-164-346-11	CERAMIC CHIP 1MF	16V
C1155	1-126-941-11	ELECT 470MF	20% 25V
C1156	1-163-038-91	CERAMIC CHIP 0.1MF	25V
C1157	1-104-664-11	ELECT 47MF	20% 25V
C1158	1-163-038-91	CERAMIC CHIP 0.1MF	25V
C1159	1-163-038-91	CERAMIC CHIP 0.1MF	25V
C1402	1-126-964-11	ELECT 10MF	20% 50V
C1404	1-163-038-91	CERAMIC CHIP 0.1MF	25V
C1405	1-163-038-91	CERAMIC CHIP 0.1MF	25V
C1406	1-163-038-91	CERAMIC CHIP 0.1MF	25V
C1407	1-163-038-91	CERAMIC CHIP 0.1MF	25V
C1408	1-164-161-11	CERAMIC CHIP 0.0022MF	10% 50V
C1409	1-164-161-11	CERAMIC CHIP 0.0022MF	10% 50V
C1410	1-164-161-11	CERAMIC CHIP 0.0022MF	10% 50V
C1411	1-164-161-11	CERAMIC CHIP 0.0022MF	10% 50V
C1414	1-164-222-11	CERAMIC CHIP 0.22MF	25V
C1415	1-126-965-11	ELECT 22MF	20% 50V
C1416	1-104-665-11	ELECT 100MF	20% 25V
C1420	1-164-005-11	CERAMIC CHIP 0.47MF	25V
C1421	1-126-961-11	ELECT 2.2MF	20% 50V
C1422	1-126-961-11	ELECT 2.2MF	20% 50V
C2201	1-126-965-11	ELECT 22MF	20% 50V
C2202	1-126-965-11	ELECT 22MF	20% 50V
C2203	1-164-232-11	CERAMIC CHIP 0.01MF	10% 50V
<CONNECTOR>			
CN261	1-573-300-21	CONNECTOR, BOARD TO BOARD 18P	
CN262	1-573-301-21	CONNECTOR, BOARD TO BOARD 20P	
CN264	* 1-691-914-11	CONNECTOR, BOARD TO BOARD 15P	
CN1401	* 1-564-508-11	PLUG, CONNECTOR 5P	
<DIODE>			
D151	8-719-404-49	DIODE MA111	
D152	8-719-404-49	DIODE MA111	
D154	8-719-404-49	DIODE MA111	
D201	8-719-032-47	DIODE MTZJ-T-9110	
D202	8-719-032-47	DIODE MTZJ-T-9110	
D203	8-719-032-47	DIODE MTZJ-T-9110	
D204	8-719-032-47	DIODE MTZJ-T-9110	
D205	8-719-032-47	DIODE MTZJ-T-9110	
D231	8-719-032-47	DIODE MTZJ-T-9110	
D232	8-719-032-47	DIODE MTZJ-T-9110	
D233	8-719-032-47	DIODE MTZJ-T-9110	
D234	8-719-032-47	DIODE MTZJ-T-9110	



REF NO	PART NO	DESCRIPTION	REMARK	REF NO	PART NO	DESCRIPTION	REMARK
D235	8-719-032-47	DIODE MTZJ-T-9110		Q237	8-729-026-49	TRANSISTOR 2SA1037AK-T146-R	
D236	8-719-032-47	DIODE MTZJ-T-9110		Q238	8-729-026-49	TRANSISTOR 2SA1037AK-T146-R	
D237	8-719-032-47	DIODE MTZJ-T-9110		Q239	8-729-026-49	TRANSISTOR 2SA1037AK-T146-R	
D238	8-719-032-47	DIODE MTZJ-T-9110		Q240	8-729-422-27	TRANSISTOR 2SD601A-Q	
D239	8-719-032-47	DIODE MTZJ-T-9110		Q241	8-729-422-27	TRANSISTOR 2SD601A-Q	
D245	8-719-157-94	DIODE RD3 3SB		Q242	8-729-422-27	TRANSISTOR 2SD601A-Q	
D246	8-719-157-94	DIODE RD3 3SB		Q243	8-729-026-49	TRANSISTOR 2SA1037AK-T146-R	
D247	8-719-157-94	DIODE RD3 3SB		Q244	8-729-026-49	TRANSISTOR 2SA1037AK-T146-R	
D248	8-719-157-94	DIODE RD3 3SB		Q245	8-729-026-49	TRANSISTOR 2SA1037AK-T146-R	
D249	8-719-157-94	DIODE RD3 3SB		Q246	8-729-422-27	TRANSISTOR 2SD601A-Q	
D250	8-719-157-94	DIODE RD3 3SB		Q262	8-729-026-49	TRANSISTOR 2SA1037AK-T146-R	
D261	8-719-032-47	DIODE MTZJ-T-9110		Q263	8-729-026-49	TRANSISTOR 2SA1037AK-T146-R	
D902	8-719-032-47	DIODE MTZJ-T-9110		Q264	8-729-026-49	TRANSISTOR 2SA1037AK-T146-R	
D910	8-719-032-47	DIODE MTZJ-T-9110		Q265	8-729-422-27	TRANSISTOR 2SD601A-Q	
D911	8-719-032-47	DIODE MTZJ-T-9110		Q266	8-729-026-49	TRANSISTOR 2SA1037AK-T146-R	
D912	8-719-032-47	DIODE MTZJ-T-9110		Q267	8-729-026-49	TRANSISTOR 2SA1037AK-T146-R	
D1051	8-719-404-49	DIODE MA111		Q268	8-729-026-49	TRANSISTOR 2SA1037AK-T146-R	
D1052	8-719-404-49	DIODE MA111		Q1051	8-729-026-49	TRANSISTOR 2SA1037AK-T146-R	
D2201	8-719-032-47	DIODE MTZJ-T-9110					
D2202	8-719-032-47	DIODE MTZJ-T-9110					
D2203	8-719-032-47	DIODE MTZJ-T-9110					
		<IC>					
IC151	8-759-700-44	IC NJM2902M		R151	1-216-085-00	METAL GLAZE 33K	5% 1/10W
IC152	8-759-700-44	IC NJM2902M		R152	1-216-073-00	METAL GLAZE 10K	5% 1/10W
IC153	8-759-700-44	IC NJM2902M		R153	1-216-073-00	METAL GLAZE 10K	5% 1/10W
IC154	8-759-009-06	IC MC14052BF		R154	1-216-085-00	METAL GLAZE 33K	5% 1/10W
IC155	8-759-700-44	IC NJM2902M		R155	1-216-073-00	METAL GLAZE 10K	5% 1/10W
IC156	8-759-700-44	IC NJM2902M		R156	1-216-073-00	METAL GLAZE 10K	5% 1/10W
IC157	8-759-009-06	IC MC14052BF		R157	1-216-079-00	METAL GLAZE 18K	5% 1/10W
IC261	8-752-066-69	IC CXA1845Q		R158	1-216-073-00	METAL GLAZE 10K	5% 1/10W
IC1051	8-752-058-68	IC CXA1315M		R159	1-216-073-00	METAL GLAZE 10K	5% 1/10W
IC1401	8-759-369-39	IC BH3856FS-E2		R160	1-216-079-00	METAL GLAZE 18K	5% 1/10W
IC1402	8-759-100-96	IC uPC4558G2		R161	1-216-073-00	METAL GLAZE 10K	5% 1/10W
		<JACK>		R162	1-216-073-00	METAL GLAZE 10K	5% 1/10W
J231	1-750-515-11	TERMINAL BLOCK, S 3P		R163	1-216-073-00	METAL GLAZE 10K	5% 1/10W
J232	1-750-517-11	JACK BLOCK, PIN 3P		R164	1-216-065-00	METAL GLAZE 4 7K	5% 1/10W
J233	1-750-516-11	JACK BLOCK, PIN 2P		R165	1-216-073-00	METAL GLAZE 10K	5% 1/10W
J234	1-750-517-11	JACK BLOCK, PIN 3P		R167	1-216-091-00	METAL GLAZE 56K	5% 1/10W
J235	1-750-517-11	JACK BLOCK, PIN 3P		R168	1-216-075-00	METAL GLAZE 12K	5% 1/10W
J236	1-774-358-11	JACK BLOCK, PIN		R169	1-216-097-91	METAL GLAZE 100K	5% 1/10W
J902	1-764-143-11	JACK 3P		R170	1-216-049-91	METAL GLAZE 1K	5% 1/10W
J903	1-764-143-11	JACK 3P		R171	1-216-049-91	METAL GLAZE 1K	5% 1/10W
J904	1-764-143-11	JACK 3P		R172	1-216-097-91	METAL GLAZE 100K	5% 1/10W
J905	1-764-143-11	JACK 3P		R173	1-216-081-00	METAL GLAZE 22K	5% 1/10W
		<COIL>		R174	1-216-081-00	METAL GLAZE 22K	5% 1/10W
L261	1-410-482-31	INDUCTOR 100UH		R175	1-216-081-00	METAL GLAZE 22K	5% 1/10W
		<TRANSISTOR>		R176	1-216-081-00	METAL GLAZE 22K	5% 1/10W
Q202	8-729-422-27	TRANSISTOR 2SD601A-Q		R178	1-216-091-00	METAL GLAZE 56K	5% 1/10W
Q203	8-729-422-27	TRANSISTOR 2SD601A-Q		R179	1-216-097-91	METAL GLAZE 100K	5% 1/10W
Q205	8-729-026-49	TRANSISTOR 2SA1037AK-T146-R		R180	1-216-097-91	METAL GLAZE 100K	5% 1/10W
Q206	8-729-026-49	TRANSISTOR 2SA1037AK-T146-R		R181	1-216-049-91	METAL GLAZE 1K	5% 1/10W
Q208	8-729-422-27	TRANSISTOR 2SD601A-Q		R183	1-216-081-00	METAL GLAZE 22K	5% 1/10W
Q209	8-729-422-27	TRANSISTOR 2SD601A-Q		R184	1-216-081-00	METAL GLAZE 22K	5% 1/10W
Q210	8-729-422-27	TRANSISTOR 2SD601A-Q		R185	1-216-081-00	METAL GLAZE 22K	5% 1/10W
Q211	8-729-026-49	TRANSISTOR 2SA1037AK-T146-R		R186	1-216-089-91	METAL GLAZE 47K	5% 1/10W
Q212	8-729-422-27	TRANSISTOR 2SD601A-Q		R187	1-216-099-00	METAL GLAZE 120K	5% 1/10W
Q231	8-729-422-27	TRANSISTOR 2SD601A-Q		R188	1-216-097-91	METAL GLAZE 100K	5% 1/10W
Q233	8-729-422-27	TRANSISTOR 2SD601A-Q		R189	1-216-097-91	METAL GLAZE 100K	5% 1/10W
Q234	8-729-422-27	TRANSISTOR 2SD601A-Q		R190	1-216-081-00	METAL GLAZE 22K	5% 1/10W
Q235	8-729-422-27	TRANSISTOR 2SD601A-Q		R191	1-216-089-91	METAL GLAZE 47K	5% 1/10W
Q236	8-729-422-27	TRANSISTOR 2SD601A-Q		R192	1-216-063-91	METAL GLAZE 3 9K	5% 1/10W
				R193	1-216-099-00	METAL GLAZE 120K	5% 1/10W
				R194	1-216-097-91	METAL GLAZE 100K	5% 1/10W
				R195	1-216-075-00	METAL GLAZE 12K	5% 1/10W
				R196	1-216-089-91	METAL GLAZE 47K	5% 1/10W
				R197	1-216-097-91	METAL GLAZE 100K	5% 1/10W
				R198	1-216-081-00	METAL GLAZE 22K	5% 1/10W
				R199	1-216-089-91	METAL GLAZE 47K	5% 1/10W
				R200	1-216-081-00	METAL GLAZE 22K	5% 1/10W

KV-32XBR48/34XBR48C/35XBR48/35XBR88/37XBR48M

RM-Y144

RM-Y144

RM-Y144

RM-Y144

RM-Y144



REF. NO.	PART NO	DESCRIPTION	REMARK	REF NO	PART NO	DESCRIPTION	REMARK
R201	1-216-022-00	METAL GLAZE 75	5% 1/10W	R279	1-216-025-91	METAL GLAZE 100	5% 1/10W
R202	1-216-022-00	METAL GLAZE 75	5% 1/10W	R280	1-216-067-00	METAL GLAZE 5 6K	5% 1/10W
R203	1-216-022-00	METAL GLAZE 75	5% 1/10W	R281	1-216-025-91	METAL GLAZE 100	5% 1/10W
R204	1-216-113-00	METAL GLAZE 470K	5% 1/10W	R282	1-216-025-91	METAL GLAZE 100	5% 1/10W
R205	1-216-113-00	METAL GLAZE 470K	5% 1/10W	R283	1-216-049-91	METAL GLAZE 1K	5% 1/10W
R206	1-216-295-91	CONDUCTOR, CHIP		R284	1-216-033-00	METAL GLAZE 220	5% 1/10W
R207	1-216-295-91	CONDUCTOR, CHIP		R285	1-216-033-00	METAL GLAZE 220	5% 1/10W
R208	1-216-295-91	CONDUCTOR, CHIP		R286	1-216-067-00	METAL GLAZE 5.6K	5% 1/10W
R211	1-216-089-91	METAL GLAZE 47K	5% 1/10W	R287	1-216-025-91	METAL GLAZE 100	5% 1/10W
R212	1-216-081-00	METAL GLAZE 22K	5% 1/10W	R288	1-216-067-00	METAL GLAZE 5 6K	5% 1/10W
R213	1-216-089-91	METAL GLAZE 47K	5% 1/10W	R289	1-216-067-00	METAL GLAZE 5 6K	5% 1/10W
R214	1-216-081-00	METAL GLAZE 22K	5% 1/10W	R290	1-216-025-91	METAL GLAZE 100	5% 1/10W
R218	1-208-774-11	METAL GLAZE 470	0.50% 1/10W	R291	1-216-067-00	METAL GLAZE 5 6K	5% 1/10W
R219	1-216-049-91	METAL GLAZE 1K	5% 1/10W	R292	1-216-025-91	METAL GLAZE 100	5% 1/10W
R220	1-208-776-11	METAL GLAZE 560	0.50% 1/10W	R293	1-216-025-91	METAL GLAZE 100	5% 1/10W
R221	1-208-774-11	METAL GLAZE 470	0.50% 1/10W	R294	1-216-077-00	METAL GLAZE 15K	5% 1/10W
R222	1-216-049-91	METAL GLAZE 1K	5% 1/10W	R295	1-216-025-91	METAL GLAZE 100	5% 1/10W
R223	1-208-776-11	METAL GLAZE 560	0.50% 1/10W	R296	1-216-025-91	METAL GLAZE 100	5% 1/10W
R225	1-216-025-91	METAL GLAZE 100	5% 1/10W	R297	1-216-025-91	METAL GLAZE 100	5% 1/10W
R226	1-216-025-91	METAL GLAZE 100	5% 1/10W	R298	1-216-025-91	METAL GLAZE 100	5% 1/10W
R228	1-216-049-91	METAL GLAZE 1K	5% 1/10W	R300	1-216-025-91	METAL GLAZE 100	5% 1/10W
R229	1-216-049-91	METAL GLAZE 1K	5% 1/10W	R902	1-249-405-11	CARBON 100	5% 1/4W F
R230	1-216-089-91	METAL GLAZE 47K	5% 1/10W	R919	1-216-295-91	CONDUCTOR, CHIP	
R231	1-216-022-00	METAL GLAZE 75	5% 1/10W	R921	1-249-405-11	CARBON 100	5% 1/4W F
R232	1-216-022-00	METAL GLAZE 75	5% 1/10W	R923	1-249-405-11	CARBON 100	5% 1/4W F
R233	1-216-065-00	METAL GLAZE 4.7K	5% 1/10W	R925	1-249-405-11	CARBON 100	5% 1/4W F
R234	1-216-022-00	METAL GLAZE 75	5% 1/10W	R926	1-216-049-91	METAL GLAZE 1K	5% 1/10W
R235	1-216-113-00	METAL GLAZE 470K	5% 1/10W	R1051	1-216-073-00	METAL GLAZE 10K	5% 1/10W
R236	1-216-113-00	METAL GLAZE 470K	5% 1/10W	R1052	1-216-073-00	METAL GLAZE 10K	5% 1/10W
R237	1-216-022-00	METAL GLAZE 75	5% 1/10W	R1053	1-216-025-91	METAL GLAZE 100	5% 1/10W
R238	1-216-113-00	METAL GLAZE 470K	5% 1/10W	R1054	1-216-025-91	METAL GLAZE 100	5% 1/10W
R239	1-216-113-00	METAL GLAZE 470K	5% 1/10W	R1055	1-216-073-00	METAL GLAZE 10K	5% 1/10W
R240	1-216-097-91	METAL GLAZE 100K	5% 1/10W	R1056	1-216-073-00	METAL GLAZE 10K	5% 1/10W
R241	1-216-113-00	METAL GLAZE 470K	5% 1/10W	R1057	1-216-025-91	METAL GLAZE 100	5% 1/10W
R242	1-216-049-91	METAL GLAZE 1K	5% 1/10W	R1058	1-216-025-91	METAL GLAZE 100	5% 1/10W
R243	1-216-113-00	METAL GLAZE 470K	5% 1/10W	R1059	1-216-065-00	METAL GLAZE 4 7K	5% 1/10W
R244	1-216-049-91	METAL GLAZE 1K	5% 1/10W	R1060	1-216-073-00	METAL GLAZE 10K	5% 1/10W
R245	1-216-022-00	METAL GLAZE 75	5% 1/10W	R1062	1-216-025-91	METAL GLAZE 100	5% 1/10W
R246	1-216-113-00	METAL GLAZE 470K	5% 1/10W	R1063	1-216-073-00	METAL GLAZE 10K	5% 1/10W
R247	1-216-113-00	METAL GLAZE 470K	5% 1/10W	R1064	1-216-073-00	METAL GLAZE 10K	5% 1/10W
R248	1-216-113-00	METAL GLAZE 470K	5% 1/10W	R1065	1-216-025-91	METAL GLAZE 100	5% 1/10W
R249	1-216-065-00	METAL GLAZE 4 7K	5% 1/10W	R1151	1-216-053-00	METAL GLAZE 1 5K	5% 1/10W
R250	1-216-065-00	METAL GLAZE 4.7K	5% 1/10W	R1152	1-216-049-91	METAL GLAZE 1K	5% 1/10W
R251	1-216-065-00	METAL GLAZE 4 7K	5% 1/10W	R1153	1-216-097-91	METAL GLAZE 100K	5% 1/10W
R252	1-216-049-91	METAL GLAZE 1K	5% 1/10W	R1154	1-216-049-91	METAL GLAZE 1K	5% 1/10W
R254	1-216-049-91	METAL GLAZE 1K	5% 1/10W	R1156	1-216-073-00	METAL GLAZE 10K	5% 1/10W
R256	1-216-295-91	CONDUCTOR, CHIP		R1157	1-216-073-00	METAL GLAZE 10K	5% 1/10W
R257	1-216-049-91	METAL GLAZE 1K	5% 1/10W	R1158	1-216-065-00	METAL GLAZE 4.7K	5% 1/10W
R258	1-216-065-00	METAL GLAZE 4 7K	5% 1/10W	R1159	1-216-065-00	METAL GLAZE 4 7K	5% 1/10W
R259	1-216-049-91	METAL GLAZE 1K	5% 1/10W	R1160	1-216-049-91	METAL GLAZE 1K	5% 1/10W
R260	1-216-065-00	METAL GLAZE 4 7K	5% 1/10W	R1161	1-216-049-91	METAL GLAZE 1K	5% 1/10W
R261	1-216-025-91	METAL GLAZE 100	5% 1/10W	R1162	1-216-049-91	METAL GLAZE 1K	5% 1/10W
R262	1-216-067-00	METAL GLAZE 5 6K	5% 1/10W	R1163	1-216-049-91	METAL GLAZE 1K	5% 1/10W
R263	1-216-025-91	METAL GLAZE 100	5% 1/10W	R1164	1-216-049-91	METAL GLAZE 1K	5% 1/10W
R264	1-216-067-00	METAL GLAZE 5 6K	5% 1/10W	R1165	1-216-049-91	METAL GLAZE 1K	5% 1/10W
R265	1-216-025-91	METAL GLAZE 100	5% 1/10W	R1166	1-216-049-91	METAL GLAZE 1K	5% 1/10W
R266	1-216-025-91	METAL GLAZE 100	5% 1/10W	R1167	1-216-049-91	METAL GLAZE 1K	5% 1/10W
R267	1-216-025-91	METAL GLAZE 100	5% 1/10W	R1168	1-216-049-91	METAL GLAZE 1K	5% 1/10W
R268	1-216-067-00	METAL GLAZE 5 6K	5% 1/10W	R1169	1-216-081-00	METAL GLAZE 22K	5% 1/10W
R269	1-216-067-00	METAL GLAZE 5 6K	5% 1/10W	R1170	1-216-073-00	METAL GLAZE 10K	5% 1/10W
R270	1-216-049-91	METAL GLAZE 1K	5% 1/10W	R1171	1-216-073-00	METAL GLAZE 10K	5% 1/10W
R271	1-216-067-00	METAL GLAZE 5 6K	5% 1/10W	R1172	1-216-097-91	METAL GLAZE 100K	5% 1/10W
R272	1-216-025-91	METAL GLAZE 100	5% 1/10W	R1173	1-216-081-00	METAL GLAZE 22K	5% 1/10W
R273	1-216-067-00	METAL GLAZE 5 6K	5% 1/10W	R1174	1-216-081-00	METAL GLAZE 22K	5% 1/10W
R274	1-216-049-91	METAL GLAZE 1K	5% 1/10W	R1175	1-216-081-00	METAL GLAZE 22K	5% 1/10W
R275	1-216-025-91	METAL GLAZE 100	5% 1/10W	R1176	1-216-081-00	METAL GLAZE 22K	5% 1/10W
R276	1-216-295-91	CONDUCTOR, CHIP		R1177	1-216-049-91	METAL GLAZE 1K	5% 1/10W
R278	1-216-067-00	METAL GLAZE 5 6K	5% 1/10W	R1178	1-216-049-91	METAL GLAZE 1K	5% 1/10W
				R1179	1-216-081-00	METAL GLAZE 22K	5% 1/10W

The components identified by shading and mark Δ are critical for safety. Replace only with part number specified.

Les composants identifiés par une trame et une marque Δ sont critiques pour la sécurité. Ne les remplacer que par une pièce portant le numéro spécifié.



REF. NO.	PART NO	DESCRIPTION	REMARK
R1180	1-216-073-00	METAL GLAZE 10K	5% 1/10W
R1181	1-216-073-00	METAL GLAZE 10K	5% 1/10W
R1182	1-216-081-00	METAL GLAZE 22K	5% 1/10W
R1183	1-216-097-91	METAL GLAZE 100K	5% 1/10W
R1184	1-216-073-00	METAL GLAZE 10K	5% 1/10W
R1185	1-216-073-00	METAL GLAZE 10K	5% 1/10W
R1186	1-216-065-00	METAL GLAZE 4.7K	5% 1/10W
R1187	1-216-073-00	METAL GLAZE 10K	5% 1/10W
R1188	1-216-073-00	METAL GLAZE 10K	5% 1/10W
R1189	1-216-057-00	METAL GLAZE 2.2K	5% 1/10W
R1190	1-216-081-00	METAL GLAZE 22K	5% 1/10W
R1191	1-216-017-91	METAL GLAZE 47	5% 1/10W
R1192	1-216-017-91	METAL GLAZE 47	5% 1/10W
R1193	1-216-099-00	METAL GLAZE 120K	5% 1/10W
R1194	1-208-291-11	METAL GLAZE 4.7M	5% 1/10W
R1195	1-216-089-91	METAL GLAZE 47K	5% 1/10W
R1196	1-208-291-11	METAL GLAZE 4.7M	5% 1/10W
R1197	1-216-073-00	METAL GLAZE 10K	5% 1/10W
R1198	1-216-063-91	METAL GLAZE 3.9K	5% 1/10W
R1199	1-216-097-91	METAL GLAZE 100K	5% 1/10W
R1200	1-216-097-91	METAL GLAZE 100K	5% 1/10W
R1201	1-216-089-91	METAL GLAZE 47K	5% 1/10W
R1202	1-216-053-00	METAL GLAZE 1.5K	5% 1/10W
R1203	1-216-089-91	METAL GLAZE 47K	5% 1/10W
R1204	1-216-049-91	METAL GLAZE 1K	5% 1/10W
R1205	1-216-049-91	METAL GLAZE 1K	5% 1/10W
R1207	1-216-025-91	METAL GLAZE 100	5% 1/10W
R1208	1-216-049-91	METAL GLAZE 1K	5% 1/10W
R1209	1-216-295-91	CONDUCTOR, CHIP	
R1211	1-216-089-91	METAL GLAZE 47K	5% 1/10W
R1212	1-216-081-00	METAL GLAZE 22K	5% 1/10W
R1213	1-216-049-91	METAL GLAZE 1K	5% 1/10W
R1214	1-208-774-11	METAL GLAZE 470	0.50% 1/10W
R1215	1-208-776-11	METAL GLAZE 560	0.50% 1/10W
R1216	1-216-025-91	METAL GLAZE 100	5% 1/10W
R1217	1-216-049-91	METAL GLAZE 1K	5% 1/10W
R1242	1-216-065-00	METAL GLAZE 4.7K	5% 1/10W
R1243	1-216-065-00	METAL GLAZE 4.7K	5% 1/10W
R1244	1-216-049-91	METAL GLAZE 1K	5% 1/10W
R1245	1-216-049-91	METAL GLAZE 1K	5% 1/10W
R1246	1-216-022-00	METAL GLAZE 75	5% 1/10W
R1247	1-216-113-00	METAL GLAZE 470K	5% 1/10W
R1248	1-216-113-00	METAL GLAZE 470K	5% 1/10W
R1249	1-216-113-00	METAL GLAZE 470K	5% 1/10W
R1250	1-216-065-00	METAL GLAZE 4.7K	5% 1/10W
R1251	1-216-049-91	METAL GLAZE 1K	5% 1/10W
R1252	1-216-065-00	METAL GLAZE 4.7K	5% 1/10W
R1254	1-216-049-91	METAL GLAZE 1K	5% 1/10W
R1255	1-216-065-00	METAL GLAZE 4.7K	5% 1/10W
R1256	1-216-065-00	METAL GLAZE 4.7K	5% 1/10W
R1257	1-216-065-00	METAL GLAZE 4.7K	5% 1/10W
R1258	1-216-049-91	METAL GLAZE 1K	5% 1/10W
R1259	1-216-049-91	METAL GLAZE 1K	5% 1/10W
R1260	1-216-295-91	CONDUCTOR, CHIP	
R1261	1-208-774-11	METAL GLAZE 470	0.50% 1/10W
R1262	1-208-776-11	METAL GLAZE 560	0.50% 1/10W
R1263	1-216-295-91	CONDUCTOR, CHIP	
R1264	1-216-049-91	METAL GLAZE 1K	5% 1/10W
R1265	1-216-025-91	METAL GLAZE 100	5% 1/10W
R1266	1-216-041-00	METAL GLAZE 470	5% 1/10W
R1267	1-216-025-91	METAL GLAZE 100	5% 1/10W
R1268	1-216-049-91	METAL GLAZE 1K	5% 1/10W
R1269	1-216-041-00	METAL GLAZE 470	5% 1/10W
R1270	1-216-049-91	METAL GLAZE 1K	5% 1/10W
R1271	1-216-025-91	METAL GLAZE 100	5% 1/10W
R1272	1-208-774-11	METAL GLAZE 470	0.50% 1/10W
R1273	1-208-777-11	METAL GLAZE 620	0.50% 1/10W
R1274	1-216-049-91	METAL GLAZE 1K	5% 1/10W

REF NO	PART NO	DESCRIPTION	REMARK
R1275	1-216-097-91	METAL GLAZE 100K	5% 1/10W
R1276	1-216-041-00	METAL GLAZE 470	5% 1/10W
R1277	1-216-025-91	METAL GLAZE 100	5% 1/10W
R1278	1-216-025-91	METAL GLAZE 100	5% 1/10W
R1279	1-216-025-91	METAL GLAZE 100	5% 1/10W
R1280	1-216-025-91	METAL GLAZE 100	5% 1/10W
R1281	1-216-049-91	METAL GLAZE 1K	5% 1/10W
R1282	1-216-025-91	METAL GLAZE 100	5% 1/10W
R1283	1-216-295-91	CONDUCTOR, CHIP	
R1284	1-216-295-91	CONDUCTOR, CHIP	
R1286	1-216-295-91	CONDUCTOR, CHIP	
R1287	1-216-295-91	CONDUCTOR, CHIP	
R1288	1-216-295-91	CONDUCTOR, CHIP	
R1289	1-216-295-91	CONDUCTOR, CHIP	
R1290	1-216-295-91	CONDUCTOR, CHIP	
R1291	1-216-295-91	CONDUCTOR, CHIP	
R1292	1-216-295-91	CONDUCTOR, CHIP	
R1293	1-216-049-91	METAL GLAZE 1K	5% 1/10W
R1294	1-216-049-91	METAL GLAZE 1K	5% 1/10W
R1295	1-216-049-91	METAL GLAZE 1K	5% 1/10W
R1296	1-216-049-91	METAL GLAZE 1K	5% 1/10W
R1297	1-216-049-91	METAL GLAZE 1K	5% 1/10W
R1298	1-216-049-91	METAL GLAZE 1K	5% 1/10W
R1299	1-216-049-91	METAL GLAZE 1K	5% 1/10W
R1300	1-216-049-91	METAL GLAZE 1K	5% 1/10W
R1401	1-216-295-91	CONDUCTOR, CHIP	
R1406	1-216-295-91	CONDUCTOR, CHIP	
R1407	1-216-073-00	METAL GLAZE 10K	5% 1/10W
R1408	1-216-025-91	METAL GLAZE 100	5% 1/10W
R1409	1-216-025-91	METAL GLAZE 100	5% 1/10W
R1411	1-216-073-00	METAL GLAZE 10K	5% 1/10W
R1412	1-216-093-00	METAL GLAZE 68K	5% 1/10W
R1414	1-216-081-00	METAL GLAZE 22K	5% 1/10W
R1415	1-216-025-91	METAL GLAZE 100	5% 1/10W
R1418	1-216-093-00	METAL GLAZE 68K	5% 1/10W
R1419	1-216-081-00	METAL GLAZE 22K	5% 1/10W
R1421	1-216-025-91	METAL GLAZE 100	5% 1/10W
R1424	1-216-025-91	METAL GLAZE 100	5% 1/10W
R1425	1-216-025-91	METAL GLAZE 100	5% 1/10W
R2201	1-216-022-00	METAL GLAZE 75	5% 1/10W
R2202	1-216-022-00	METAL GLAZE 75	5% 1/10W
R2203	1-216-022-00	METAL GLAZE 75	5% 1/10W

* A-1241-293-A FA BOARD, COMPLETE (KV-35XBR88)

<CONNECTOR>

CN1601 1-691-960-11 PIN, CONNECTOR (PC BOARD) 3P
CN1602 * 1-580-843-11 PIN, CONNECTOR (POWER)
CN1603 Δ 1-540-062-11 OUTLET, AC (POLAR)

<FUSE>

F1601 Δ 1-576-107-12 FUSE
1-533-223-11 HOLDER, FUSE, F1601
F1602 Δ 1-576-193-11 FUSE
1-533-223-11 HOLDER, FUSE, F1602

<VARISTOR>

VDR1601 1-801-074-41 VARISTOR ERZV10D271



Les composants identifiés par une trame et une marque Δ sont critiques pour la sécurité. Ne les remplacer que par une pièce portant le numéro spécifié

The components identified by shading and mark Δ are critical for safety. Replace only with part number specified

REF. NO.	PART NO	DESCRIPTION	REMARK
	* A-1241-294-A	FB BOARD, COMPLETE (KV-35XBR88)	*****
		<CAPACITOR>	
C1621	1-126-943-11	ELECT 2200MF 20% 25V	
		<CONNECTOR>	
CN1621	1-764-101-11	PIN, CONNECTOR (PC BOARD) 2P	
CN1622	* 1-564-506-11	PLUG, CONNECTOR 3P	
		<DIODE>	
D1621	8-719-510-02	DIODE D1NS4-TA	
D1622	8-719-510-02	DIODE D1NS4-TA	
D1623	8-719-510-02	DIODE D1NS4-TA	
D1624	8-719-510-02	DIODE D1NS4-TA	
		<RESISTOR>	
R1621	1-216-371-00	METAL OXIDE 1 5 5% 2W F	
R1622	1-202-933-61	FUSIBLE 0 1 10% 1/2W F	

MISCELLANEOUS			

Δ 1-402-952-12		COIL, DEMAGNETIZATION (KV-32XBR48)	
Δ 1-411-474-11		COIL, DEMAGNETIZATION (KV-34XBR48C)	
Δ 1-411-881-12		COIL, DEMAGNETIC (KV-35XBR48/35XBR88/37XBR48M)	
Δ 1-411-882-12		COIL, DEMAGNETIC (KV-35XBR48/35XBR88/37XBR48M)	
1-431-520-11		TRANSFORMER, POWER (KV-35XBR88)	
1-452-885-11		MAGNET, LANDING (KV-32XBR48/34XBR48C)	
1-475-319-11		DOOR UNIT, AUTO (KV-35XBR88)	
1-505-684-11		SPEAKER UNIT, BOX TYPE (KV-35XBR48/35XBR88/37XBR48M)	
1-505-721-11		BOX TYPE, SPEAKER UNIT (KV-32XBR48/34XBR48C)	
* 1-556-945-21		CABLE, P-P	
* 1-557-056-31		CABLE, P-P	
Δ 1-751-039-11		CORD, POWER (WITH CONNECTOR) 10A/125V (except KV-34XBR48C)	
Δ 1-769-796-41		CORD, POWER (WITH CONNECTOR) (KV-34XBR48C)	
1-900-800-81		WIRE ASSY, G2 LEAD	
1-900-800-82		WIRE ASSY, FOCUS	
Δ 8-451-480-11		DEFLECTION YOKE Y37GX-A (KV-35XBR48/35XBR88/37XBR48M)	
Δ 8-451-482-21		DEFLECTION YOKE Y34FXA2-X (KV-32XBR48/34XBR48C)	
Δ 8-453-007-21		NA324-M2	
8-598-414-00		ANTENNA SWITCH AS-2F	
Δ 8-733-745-05		PICTURE TUBE 34FXD2(SDP) (XBR) (M80JYV51X) (KV-32XBR48)	
Δ 8-733-746-05		PICTURE TUBE 34FXD2(SDP) (FOR XBR/10UT) (M80JYV51X) (KV-34XBR48C)	
Δ 8-733-760-05		PICTURE TUBE 37GX (A99LJ780X) (KV-35XBR48/35XBR88/37XBR48M)	

REF. NO.	PART NO	DESCRIPTION	REMARK
ACCESSORIES AND PACKING MATERIALS			

3-860-371-21		MANUAL, INSTRUCTION (except KV-34XBR48C)	
3-860-371-31		MANUAL, INSTRUCTION (KV-32XBR48(CND)/35XBR48(CND))	
3-860-371-41		MANUAL, INSTRUCTION (except KV-32XBR48(CND)/35XBR48(CND))	
* 4-041-423-01		SHEET, PROTECTION (KV-35XBR88)	
* 4-041-425-01		BAG, PROTECTION (KV-35XBR88)	
* 4-049-758-11		BAG, PROTECTION (KV-32XBR48/34XBR48C)	
* 4-053-658-01		BAG, PROTECTION (KV-35XBR48/37XBR48M)	
* 4-058-409-01		CUSHION (UPPER) (ASSY) (KV-35XBR48/37XBR48M)	
* 4-058-410-01		CUSHION (LOWER) (ASSY) (KV-35XBR48/37XBR48M)	
* 4-058-415-01		INDIVIDUAL CARTON (KV-35XBR48/37XBR48M)	
* 4-058-482-01		INDIVIDUAL CARTON (KV-32XBR48/34XBR48C)	
* 4-058-483-01		CUSHION (UPPER) (ASSY) (KV-32XBR48/34XBR48C)	
* 4-058-484-01		CUSHION (LOWER) (ASSY) (KV-32XBR48/34XBR48C)	
* 4-059-759-01		CUSHION (UPPER) (ASSY) (KV-35XBR88)	
* 4-059-760-01		CUSHION (LOWER) (ASSY) (KV-35XBR88)	
* 4-059-765-01		INDIVIDUAL CARTON (KV-35XBR88)	
* 4-059-766-01		TRAY (KV-35XBR88)	
* 4-059-767-01		BOARD, BOTTOM (KV-35XBR88)	
* 4-059-768-01		BOARD, TOP (KV-35XBR88)	
* 4-059-769-01		CUSHION (FRONT) (KV-35XBR88)	
* 4-059-770-01		SHEET, CORRUGATED FIBER BOARD (KV-35XBR88)	
4-060-839-01		CARD, CUSTOMER INQUIRY (KV-32XBR48(US)/35XBR48(US))	
REMOTE COMMANDER			

1-475-306-11		REMOTE COMMANDER (RM-Y144)	
3-709-129-01		POCKET, COVER (FOR RM-Y144)	

Sony Corporation
Display Company
 Quality Assurance Department
 Service Promotion Section